



Empty Bottle Inspection (BNS) Series 6

Empty Bottle Inspection (BNS) Series 6 | Software Version 6.0

Copyright Notice / Contact Us

© 2022 Pressco Technology Inc. All rights reserved.

No part of this manual may be reproduced or transmitted in any form or by any means, electronic or mechanical, including photocopying and recording, for any purpose, without the express written permission of Pressco Technology Inc.

The contents of this manual are furnished for informational use only, are subject to change without notice, and should not be construed as a commitment by Pressco Technology Inc.

Written and designed at:

Pressco Technology Inc. World Headquarters

29200 Aurora Road

Cleveland, OH USA 44139-1847

TEL +1-440-498-2600

FAX +1-440-498-2615

www.pressco.com

Business Hours: Monday - Friday, 8:00am - 5:00pm Eastern Time

Customer Support:

Request technical support and remote support: techsupport@pressco.com

24/ 7 Customer Support (for urgent system help): +1-440-498-2000

e-mail: Schedule a service visit: dispatch@pressco.com

Request technical support and remote support: techsupport@pressco.com

Customer Service Fax: +1-440-498-4761

Table of Contents

Module 1 Pressco Introduction 7
 Inspection Terminology 8
Module 2 Hardware Overview 9
 Intellispec Cabinet and User Interface 10
 Inspection Modules 16
 Eight Channel Cluster Box S6 20
Module 3 Software Overview 21
 4 Software Screens 22
 System Overview screen 23
 Lane Overview Screen 24
 Sensor Overview Screen 25
 Inspection Overview Screen 26
 Menu Toolbar 27
 User Accounts & Login 30
Module 4 System Tools 39
 Log Reader 40
 Reporting 41
 Alarms 45
 Rejecting 63
 Support Package 68
 Save Images 73
Module 5 Lighting and Imaging 77
 Pressco Inspection Theory 78
 Part Tracker Simulation 85
 Imaging 86
 Lighting 91
 Base, Neck, Seal Lighting Adjustments 95
Module 6 Part Tracking 100
 Sequence of Events During Inspection 101
 Part Tracking Terminology 102
 Encoder 103
 Encoder/ PDX "Timing Wheel" 104
 Part Tracking Using a PDX 105

Part Width Calibration	106
Part Present Delay Calibration	107
Reject Delay and Dwell Calibration	109
Reject Confirm Calibration (optional)	110
PDX Configuration	111
Part Width Calibration using PDX	114
Module 7 System Maintenance and Troubleshooting	115
Maintenance Cautions	116
Maintenance Frequency	117
Clean the Control Cabinet Filters	118
Clean the Cluster Box Filters	119
Cleaning the Beam Splitter Seal Surface module	120
Cleaning the Beam Splitter PSE Module	121
Cleaning the Part Detector and Reflector	122
Module 7 Troubleshooting Tools and Information	123
Camera LED Indicators	124
Help - Remote Support	125
Exiting the Intellispec Software	128
Discovery Software - What is Discovery?	129
Discovery software screen	130
Discovery Menu Toolbar	131
Module 8 Part Programming - General Information	132
Part Changeover	133
Manage Part Programs	135
Create or Copy a Part Program	137
Inspection Overview	138
Inspection Tree Configuration	142
Module 9 Empty Bottle Inspections - Introduction	159
Module 10 Inspections for Base Camera	161
Create the Base Inspection Tree	162
Place the Empty Pocket ROI	165
Set up the Base Empty Pocket Inspection	166
Place the True Center ROI	168
Set up the Base Inspection Enhancement	169
Set up the True Center Registration	170

Place the Outer Base ROI	171
Set up the Outer Base Inspection	172
Place the Spoke Defects ROI	174
Set up the Spoke Defects Enhancement	175
Set up the Spoke Defects Inspection	176
Place the Orientation ROI	177
Set up the Base Orientation	178
Place the Foot ROI	179
Set up the Foot Inspection	180
Place the Between Foot ROI	181
Set up the Between Foot Inspection	182
Place the Pearling ROI	183
Set up the Pearling Inspection	184
Place the Gate Registration ROI	185
Set up the Gate Registration	186
Place the Gate ROI	187
Set up the Gate Inspection	188
Place the Around Gate ROI	189
Set up the Around Gate Inspection	190
Place the Base Fold ROI	191
Set up the Base Fold Inspection	192
Set up the Off-Center Gate Inspection	193
Module 11 Inspections for Neck Camera	195
Create the Neck Inspection Tree	196
Place the Empty Pocket ROI	199
Set up the Neck Empty Pocket Inspection	200
Place the Color ROI	202
Set up the Color Inspection	203
Place the Lower Neck Registration ROI	204
Set up the Lower Neck Registration	206
Place the Lower Neck ROI	208
Set up the Lower Neck Inspection	209
Place the Upper Neck Registration ROI	210
Set up the Upper Neck Registration	212

Place the Upper Neck ROI	214
Set up the Upper Neck Inspection	215
Place the High Choke Registration ROI	216
Set up the High Choke Registration	218
Place the High Choke ROI	220
Set up the High Choke Inspection	221
Module 12 Inspections for Seal Camera	222
Create the Seal Inspection Tree	223
Place the Empty Pocket Center ROI	224
Set up the Empty Pocket Center Registration	225
Place the Empty Pocket ROI	227
Set Up the Seal Empty Pocket Inspection	228
Place the Seal Center ROI	230
Set up the Seal Center Registration	232
Place the Seal Surface ROI	234
Set up the Seal Surface Inspection	235
Place the Choked Neck ROI	237
Set up the Choked Neck Inspection	238
Place the Ovality ROI	239
Set up the Ovality Inspection	240
Module 12 Inspections for Intellimass	246
Create the Base Mass Inspection Tree	247
Set Up the Base Mass Empty Pocket Inspection	248
Set up the Base Mass Inspection	249
Create the Sidewall Mass Inspection Tree	250
Set Up the Side Mass Empty Pocket Inspection	251
Set up the Side Mass Inspection	252

Module 1 Pressco Introduction

Welcome!

Congratulations on your purchase of an Intellispec system! The Intellispec is a high-speed machine vision system designed specifically for product and online process monitoring. It is a powerful tool that provides inspection much more reliably than the human eye or sampling methods. The latest PC technology, powerful inspection algorithms, online adjustment capability, and inspection data storage allow the Intellispec to automatically inspect parts with extreme accuracy on high-speed lines.

The Intellispec will help you provide the highest quality of products shipped to your customers.

Inspection Terminology

Analysis - Analyzes the pixel shade information within a region and compares it to reference values. The inspection passes or fails based on these comparisons. There are also several analyses that make measurements. You may have many analyses for each inspection region.

Dimension - The dimension inspection type connects the results of two other inspections to do the analysis. For example, a distance inspection can connect two registrations to measure the distance between centers of two features.

Enhancements - Enhancements are used to alter images for better defect detection, or for making certain features stand out.

Inspection Module - The housing, camera, cables, and associated electronics that are installed on or over the production line to acquire an image of your product. Sometimes referred to as a tunnel. The inspection module can have a different sensor than a camera to make measurements of your product (example: Intellimass sensor).

Lane - A lane usually refers to one production line, and can contain multiple sensors.

Orientation - An orientation compensates for part rotation by finding a grayscale pattern. An analysis which must rotate with the part must follow an orientation.

Part Program - The list of regions, analyses, registrations, etc. programmed specifically for your part to detect defects or make measurements.

Part Tracking - refers to the monitoring of parts from the part detect sensor to reject station. This ensures that the correct parts are rejected at the correct time, and that good parts remain in the part stream.

Region - The Region indicates where on the part the analyses will take place. You may have as many inspections as you like in one region.

Registration - A registration compensates for part movement by finding the reference point on the part. All analyses follow a registration.

Reject - A part that failed one or more inspections from any sensor. The part can be physically rejected, or simply counted in the statistics.

Retro-Spec - The graphical interface that allows you to make quick changes to a part program. It also allows you to experiment with different parameter settings to see how changes affect the most recent inspection population, without rejecting parts.

Sensor - A camera, Intellimass, or other sensor that acquires images, measurements, or other data from your product.

Module 2 Hardware Overview

In this section:

Intellispec Cabinet and User Interface	10
Inspection Modules	16
Eight Channel Cluster Box S6	20

Intellispec Cabinet and User Interface

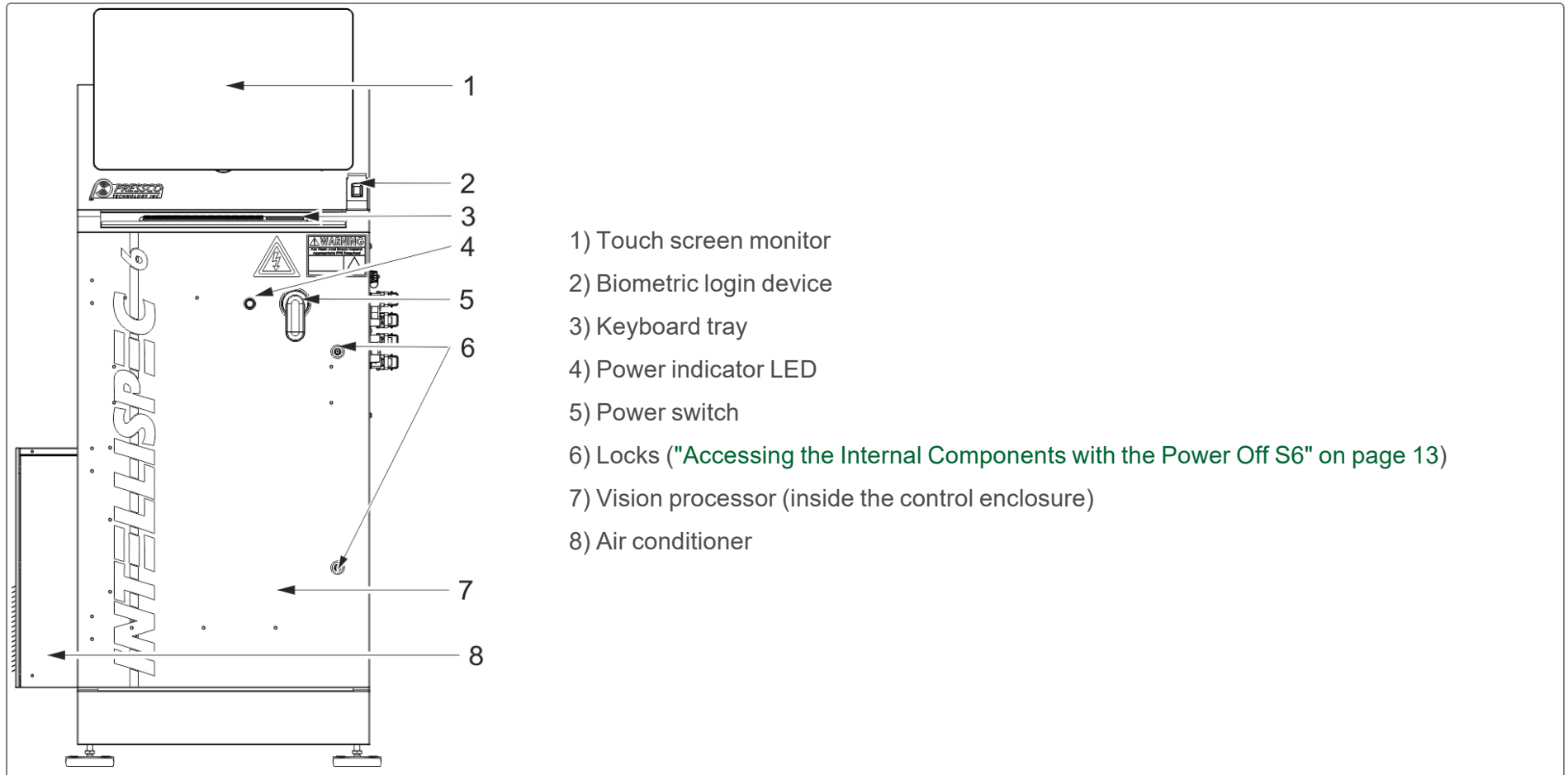

Power On and Off at the Control Enclosure

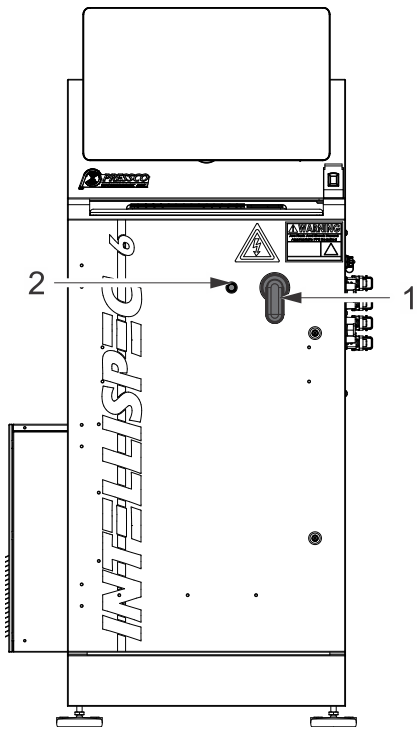

Power on: Turn on the switch [1] on the front of the cabinet. The power indicator [2] will illuminate. The software will start automatically. (You must log in and put the system online to begin inspection)

Note: it takes about a minute for the computer to start after the main power switch is turned ON

Power off: Turn off the switch on the front of the cabinet. The system, including the computer, shuts down. The UPS shuts down.

⚠ WARNING - When you shut down power using this switch, there is still voltage present on the UPS inside the unit until it discharges.

! Important - If you want to restart the system, turn off the power, let the software and components completely shut down, and leave the power off for about one minute before turning it back on. This allows the electronic components to correctly reset.

Computer Internal Components

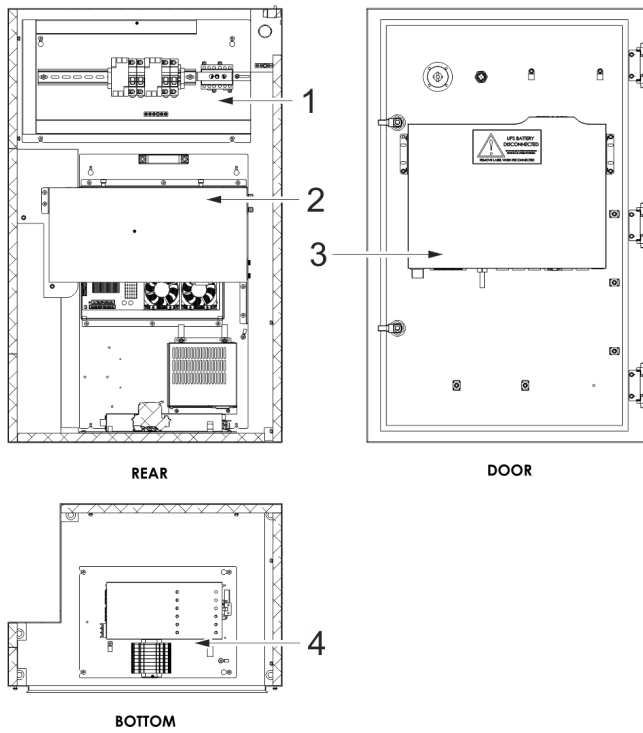

- 1) Power Entry Panel, including terminal block TB1
- 2) Vision Processor Assembly
- 3) UPS (Uninterruptible Power Supply)
- 4) DC Power Panel, including terminal block TB2

Accessing the Internal Components with the Power Off S6

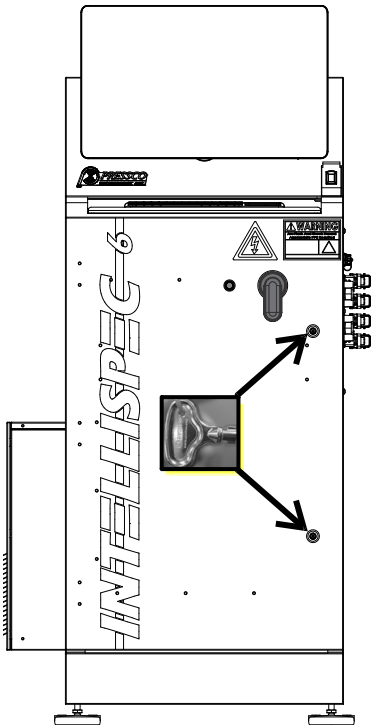

To access the components inside of the control cabinet, you will need the keys (supplied by Pressco).

⚠ WARNING - When the system is powered down, there is still voltage present at the UPS. Only **AUTHORIZED PERSONNEL** should attempt to open the system. We recommend that only **AUTHORIZED PERSONNEL** have access to the keys.

USB Ports S6

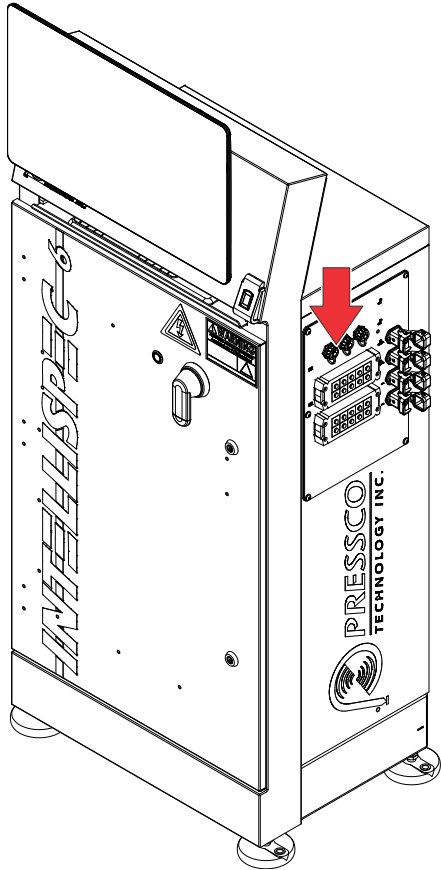

There are USB ports available to back up or transfer data

 The USB port is not for charging your phone! Only use these ports to import or export data.

Use the USB ports when you are:

- Importing or Exporting Part Programs from another system [How to Create, Copy, or Import a Part Program](#)
- Exporting user accounts
- Importing user accounts
- Creating a Support Package
- Saving images, especially to send with a support package

5-Light Tree

The lights on the optional light tree will turn on, off, or blink depending on status of certain hardware. Each lane has its own light tree.

Note: the light tree on your system may look different than the picture shown

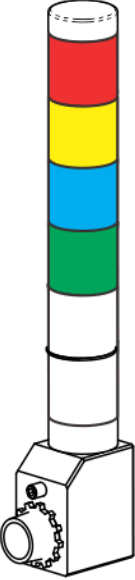
5-Light Tree	Light color	Condition	What it means
	Red	On - steady	Alarm condition
	Red	On - blinking	Part tracker board lost communication with the host PC or has an error and needs to initiate an alarm
	Red	Off	No alarm (OK)
	Amber	On - steady	Warning alarm condition
	Amber	Off	No warning (OK)
	Amber	0.5 second flash	System automatically resets Asynchronous Correlation FIFO (not used in all systems)
	Blue	On	Not assigned
	Blue	Off	Not assigned
	Green	On - steady	Lane is online
	Green	Off	Lane is offline
	White	On - steady	Power On (Part tracker board has power)
	White	Off	Power Off (Part tracker board has no power)

Blowmolder Overview - locations of cameras

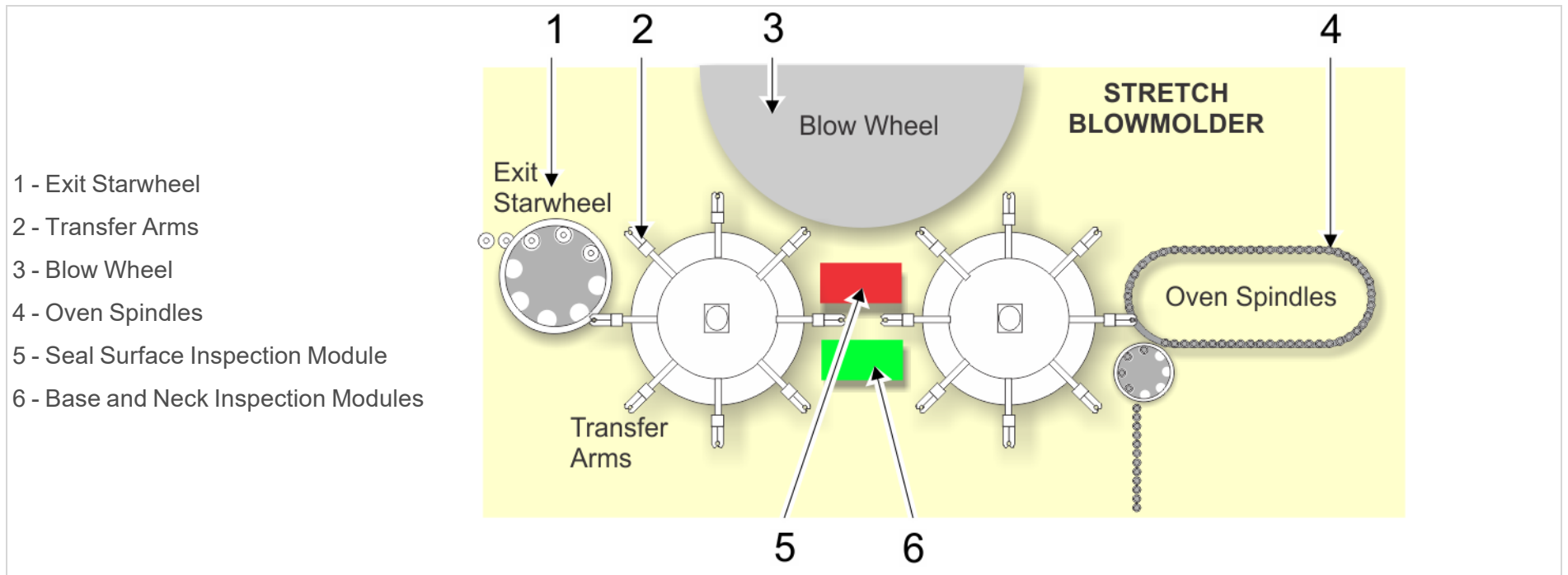

BNS Camera Modules

- 1 - Base camera
- 2 - Base light array
- 3 - Neck light array
- 4 - Neck camera
- 5 - Base and Neck cameras mounted together
- 6 - Seal camera - Light arrays (2) are inside

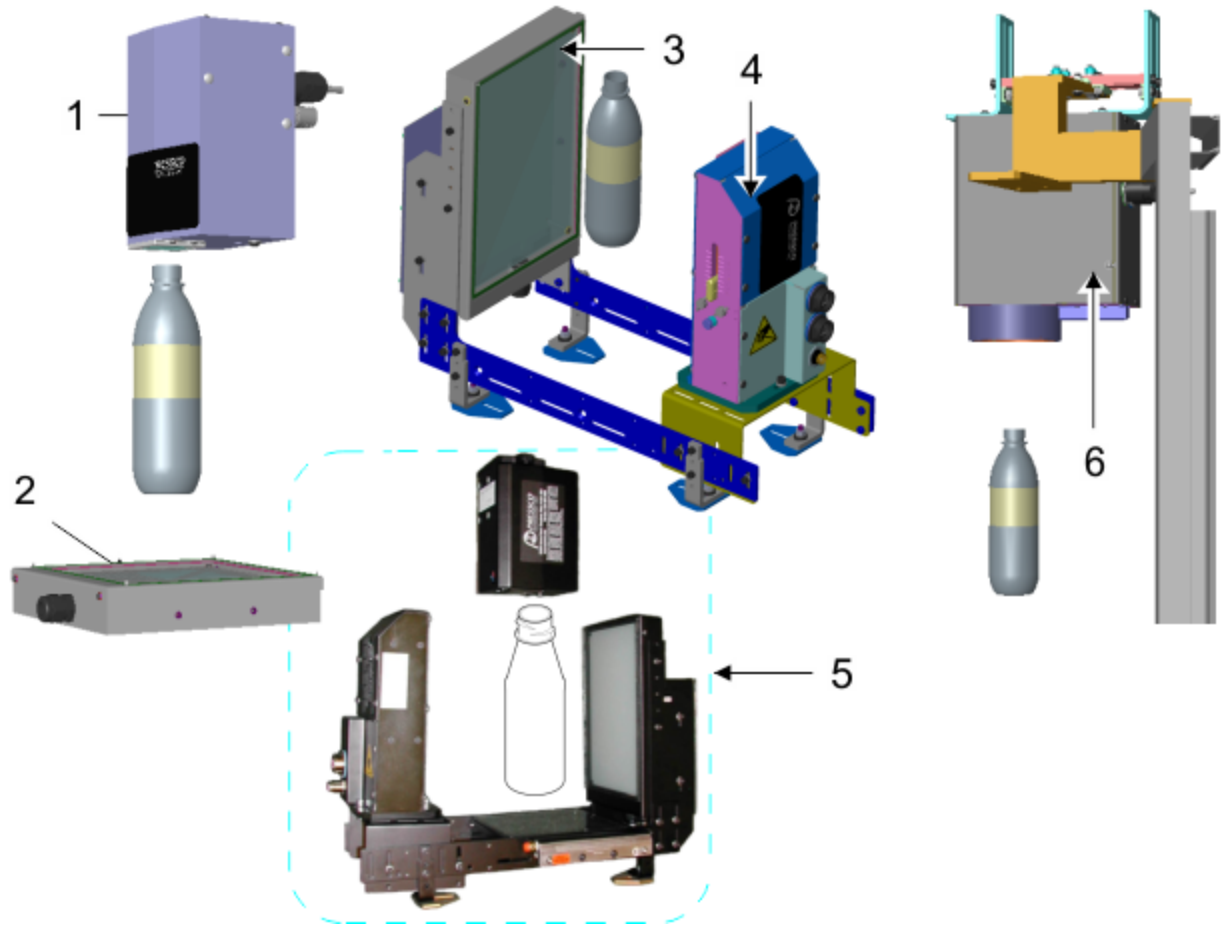

Preform Camera Modules - PWC, PW360, PSE

- 1 - PWC (preform sidewall color) module and light array
- 2 - PW360 (preform sidewall 360) module and light array
- 3 - PSE (preform seal endcap) module and light array

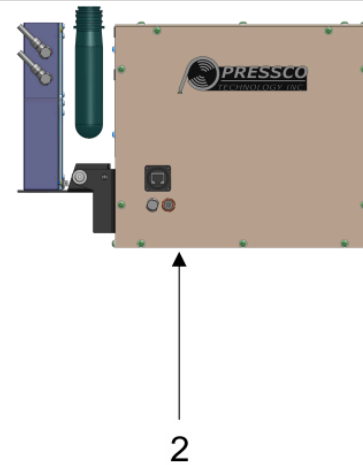
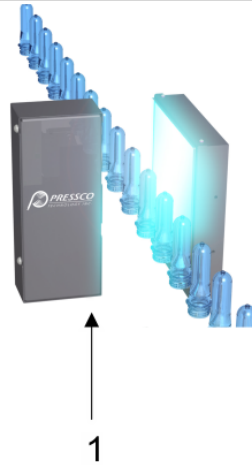

Eight Channel Cluster Box S6

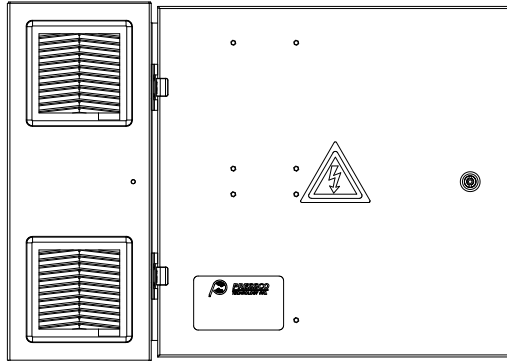
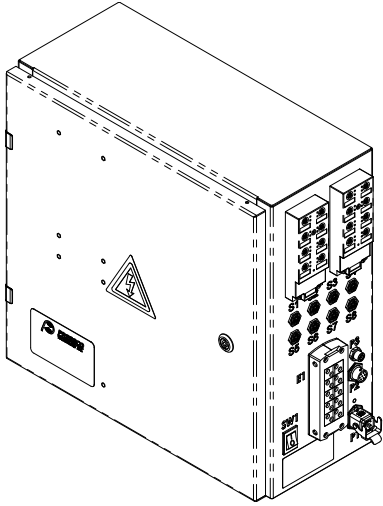

Module 3 Software Overview

In this section:

4 Software Screens	22
System Overview screen	23
Lane Overview Screen	24
Sensor Overview Screen	25
Inspection Overview Screen	26
Menu Toolbar	27
User Accounts & Login	30

4 Software Screens

This section describes the four main types of screens in the Intellispec software.

System Overview screen



Access the System Overview screen by selecting the Home icon.

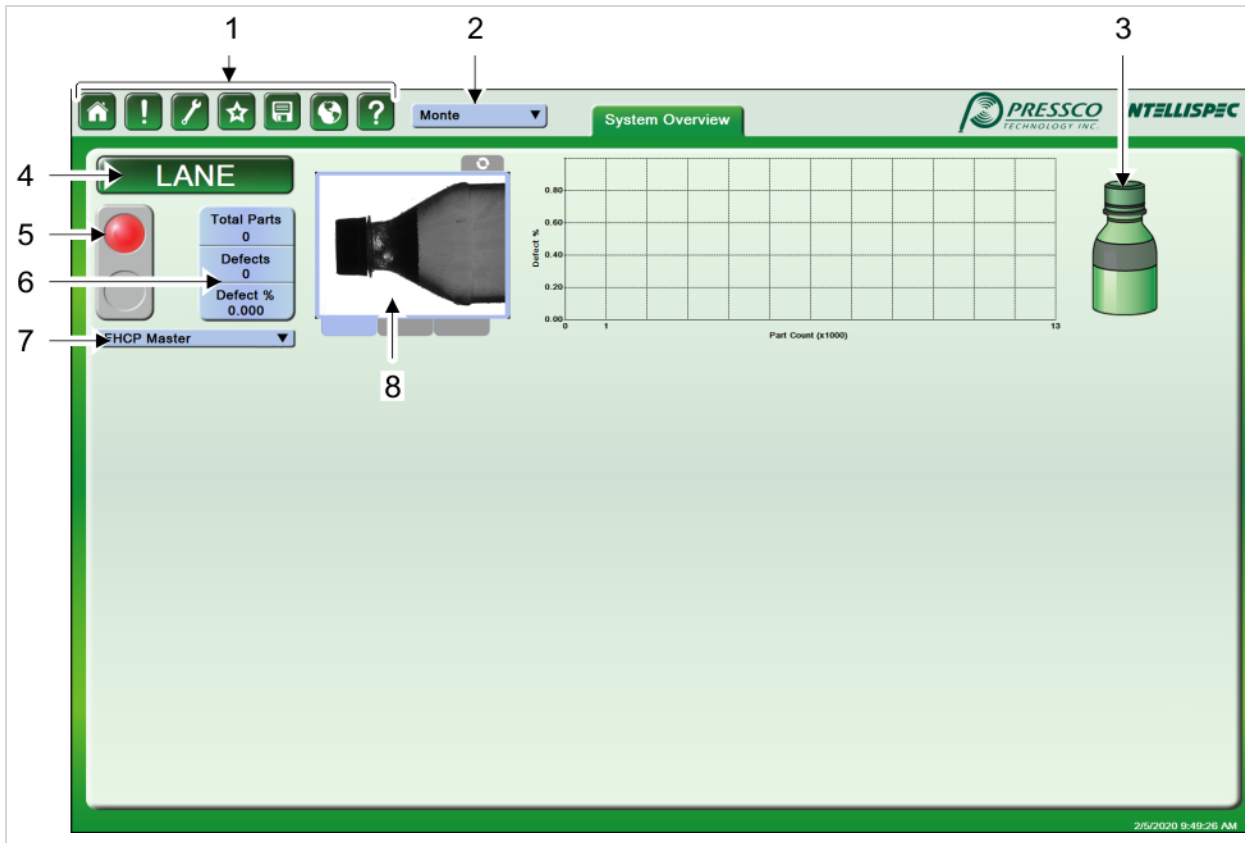

- 1) "Menu Toolbar" on page 27
- 2) Log in/ Log out.
- 3) Walk-by graphic
- 4) Go to Lane Overview
- 5) Online/ Offline
- 6) Lane Statistics
- 7) Part Program
- 8) Heartbeat Image

Note: your system may have multiple lanes. This example shows one lane.

Lane Overview Screen

Lane *n* Access a Lane Overview screen by selecting a Lane button. Your system may have multiple lanes.

2 →

1 →

1) Select the sensor button to toggle to detailed Sensor View and back

2) Switch to System Overview

Sensor Overview Screen



Penny
Defects: 98777
Defect %: 20.000

Access the Sensor Overview by selecting a sensor button. Your system may have multiple cameras/ sensors.

2 →

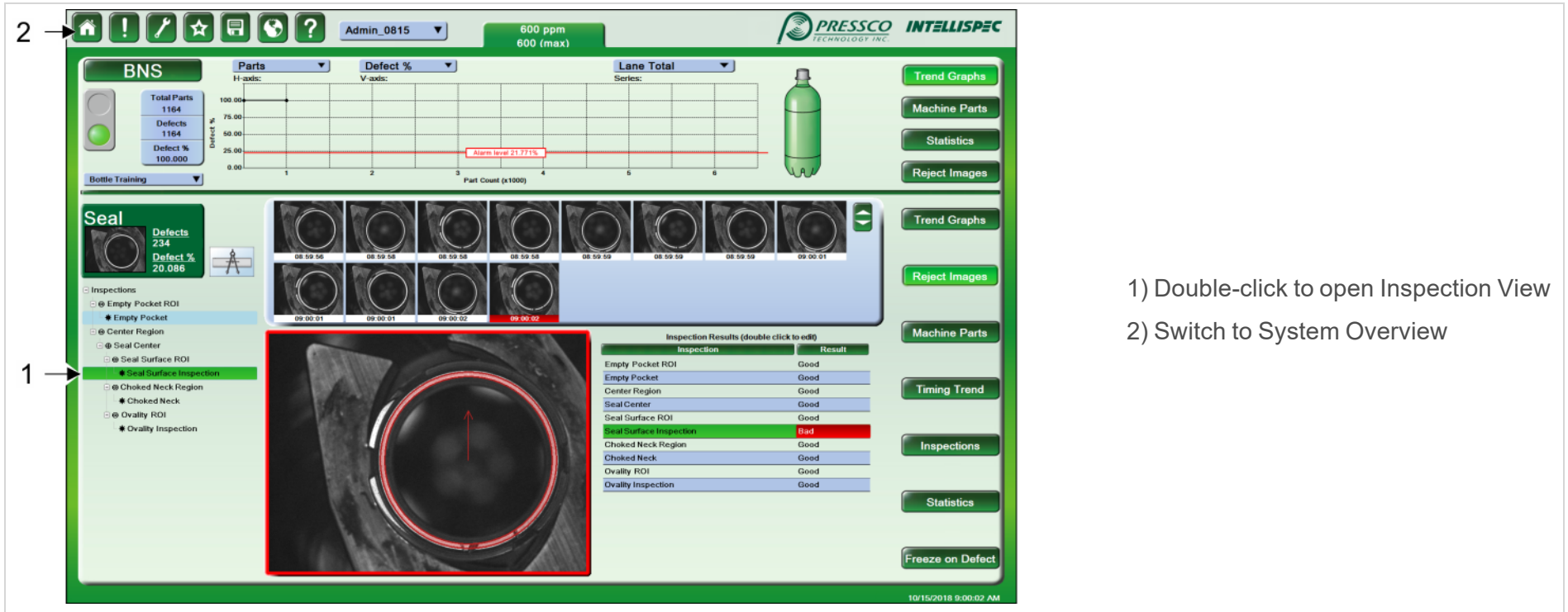

1 →

1) Double-click to open Inspection View
2) Switch to System Overview

Inspection	Result
Empty Pocket ROI	Good
Empty Pocket	Good
Center Region	Good
Seal Center	Good
Seal Surface ROI	Good
Seal Surface Inspection	Bad
Choked Neck Region	Good
Choked Neck	Good
Ovality ROI	Good
Ovality Inspection	Good

Inspection Overview Screen

Double-click an inspection name in the inspection tree to access the Inspection Overview screen. This is the screen where you may adjust inspection parameters (if you have user permission).

Two different views are available: "Retro-Spec Population View Graph" and "Retro-Spec Part View Graph." Double-click on the upper graph to switch between them.

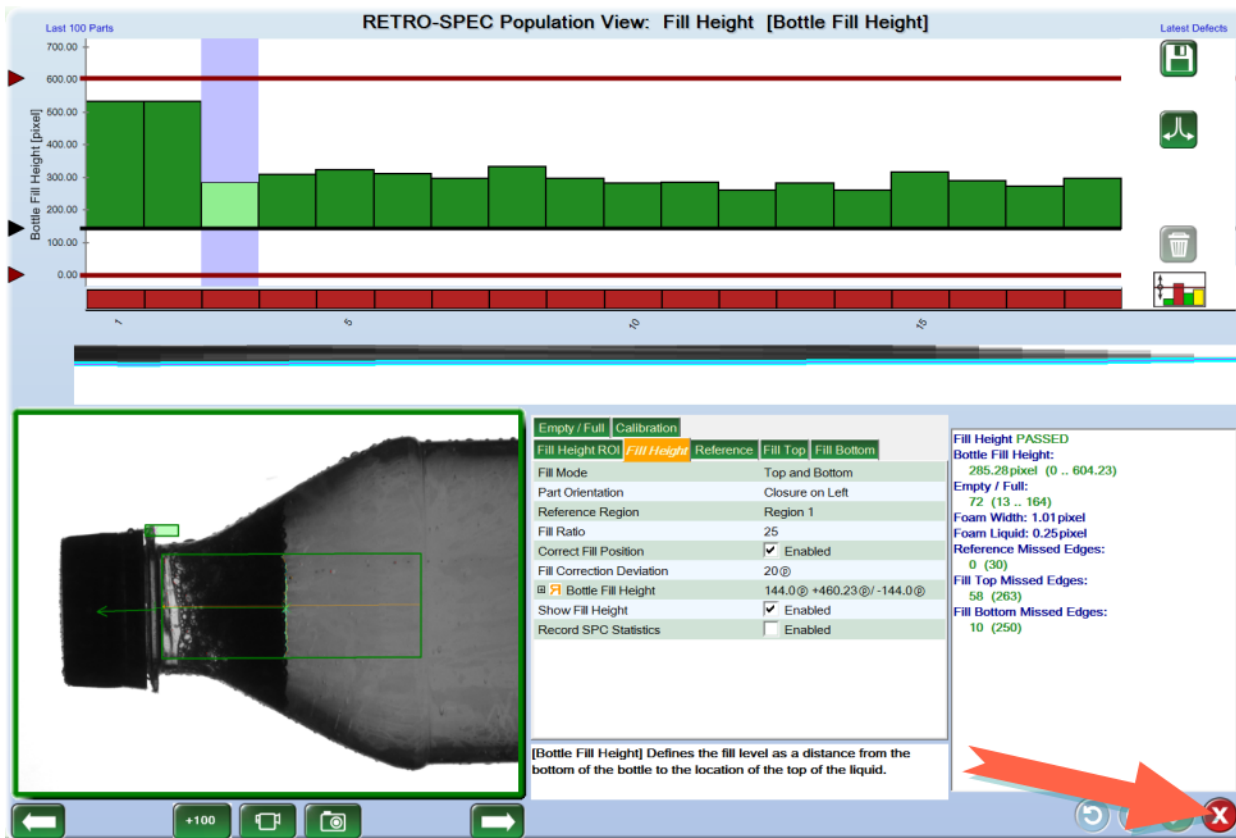

Close the Inspection View to switch to System Overview or Sensor Overview

Menu Toolbar



Note: some menu items change, depending whether you are in System Overview mode or Lane/Sensor Overview mode

- 1) **Home** - Go to the System Overview Screen
- 2) **Alarms** - Clear, view, and set alarms
- 3) **Tools menu** - Configure system settings, reports, hardware, part tracking, rejectors, part setup, and more
- 4) **Star menu** - Take screen shots and manage background tasks, and launch the OPC Client (if installed)
- 5) **Back Up and Restore Menu** - Create a support package, restore the system from a support package, and launch Windows Explorer
- 6) **Language** - Select the language to display the Intellispec software, from the available options
- 7) **Help** - Access the help documents, remote support, and determine software version

Tools menu - System Overview Screen



To get to this menu: Select the Home button | Tools .

Note: Some menu items are only available to advanced level users.

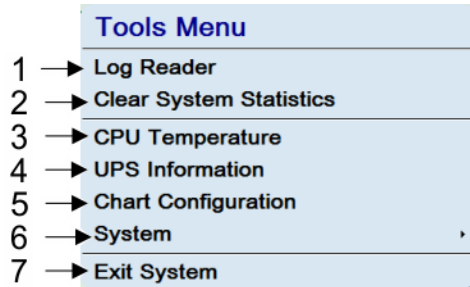

- 1) **Log Reader** - Open the Intellispec log (see also "**Log Reader**" on page 40)
- 2) **Clear System Statistics** - Clear the entire system statistics (all Lanes)
- 3) **CPU Temperature** - If a multiple core computer is used, the highest temperature is displayed. If the shutdown CPU temperature is reached, the Intellispec system shuts down.
- 4) **UPS Information** - Display Uninterruptible Power Supply (UPS) information and settings
- 5) **Chart Configuration** - Choose the Trend Graph type and the number of points for the chart in the System Overview Screen
(not shown) - **Defect Writing** - [Only if Defect Database option is installed and enabled] Enable or disable defect recording for multiple lanes.
(not shown) - **OPC Configuration** - - [Only if the OPC Server is installed] This is an optional feature that must be purchased separately.
- 6) **System** - Set system date and time or set up a printer
- 7) **Exit System** - Shut down Intellispec software

Help



Select the Help icon to:

- use the system manuals
- access Pressco remote support
- Configure a hang dump (for administrators - troubleshooting purposes)
- obtain your current software version

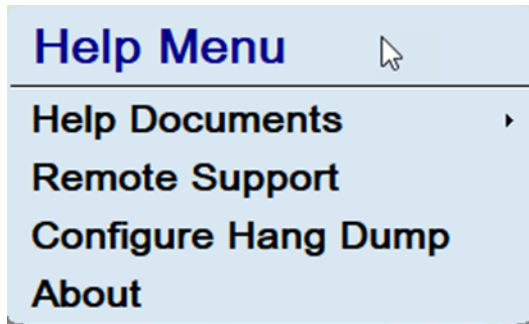

To access the user manuals:

1.  Select the Help icon.
2. Select Help Documents, then select a manual from the list. The user manual is displayed.

User Accounts & Login

This section describes how to log in and how to manage user accounts.

Biometric Login Device

The Biometric Identification login device is used to log in and out of the Pressco system. This device is optional and must be purchased with the system.



To log in with this device, press your finger to the device. The following are conditions for use:

- You must use the same finger as initially set up by your administrator
- If you do not know how your account was set up (or which finger you used), contact your administrator
- If, after three tries, the Pressco does not recognize your finger print, you must log in using the On Screen Keyboard (OSK)

Log in and log out

To log in, use either method:

- A.  Select the Log In button. Select your user name, and enter your password.
- B. With the optional biometric sensor: Press your finger to the sensor. The system logs you in. If the system fails to recognize your identity after three attempts, then log in through the log in dialog box.

To log out:

- A.  Select the button with your name, then select the Log Out button.
- B. With the optional biometric sensor: Press your finger to the sensor. The system logs you out.

Note: When another user logs in, the system automatically logs you out.

Log In menu

To ensure that only authorized users perform certain changes to the system, users are required to log in.* Some of these menu items are available to advanced users only.

*Some tasks can be configured so that users do not need to log in. This is done through the Manage Permissions menu.

To view the Log In menu:

 Select the Log In button and enter your password. The text on the button changes to indicate who is logged in.

 Select the Log In button again. The popup menu appears.

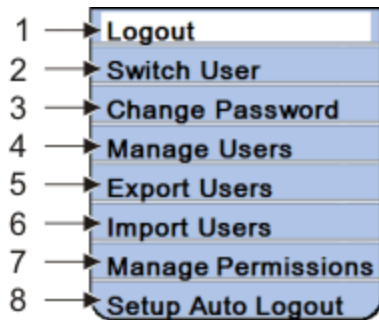

- 1) Logout
- 2) Switch user
- 3) **Change Password** - change only your password
- 4) **Manage Users** - add, remove, or edit users
- 5) **Export Users** - export user profiles from one Intellispec to another
- 6) **Import Users** - import user profiles from one Intellispec to another
- 7) **Manage Permissions** - assign specific areas of the system that a user can access
- 8) **Set Up Auto Logout** - the system logs you out if there is no activity for the specified time

Note: There is a Pressco Technician account for use only by Pressco Service Engineers. This gives access to unsupported features (menu items are a different color). If you log into this account and use those features, do so at your own risk.

User Management

Administrator only

Add, Edit, or Remove users. You may create one user account for a group of people (example: Shift 1).

Note: the biometric login features are only used when the optional biometric login device is installed

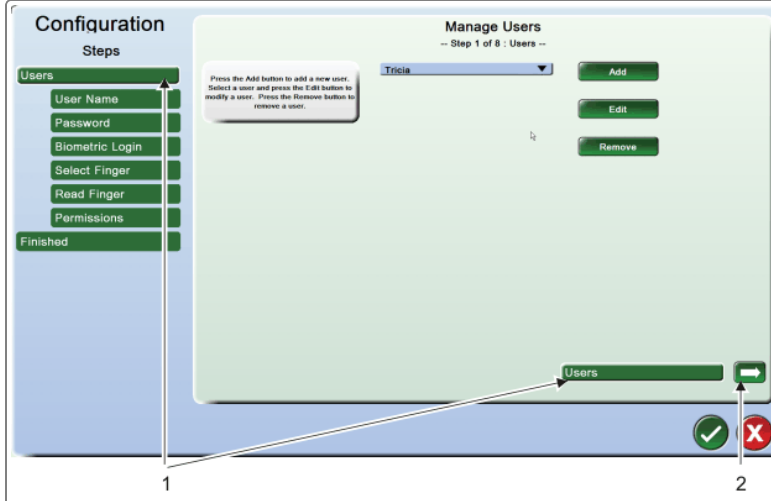

To manage a user account:

1. Log in as an administrator.
2. **Bob** Select the button with your user name | Manage Users.
3. Select Add, Edit, or Remove a user. Follow the information on screen to complete these actions. The current step is highlighted [item 1 in illustration].
4.  Use the forward arrow button [item 2] to move to the next screen(s).

Add a user with the biometric login device

The biometric device uses finger recognition software to log in. You can always log in using your user name and password, even if you have a biometric login device. The maximum number of biometric accounts is 40.

Note: You cannot create two accounts for the same finger print. You could create two accounts for one person, but you must use two different fingers

To add a user with the biometric login device:

1. Log in as Administrator.
2. **Bob** Select the button with your user name | Manage Users | Add.
3. Add the new user name when prompted. Select the forward arrow.
4. Enter a password, then Confirm it. Select the forward arrow.
5. [Biometric login] Select Biometric.

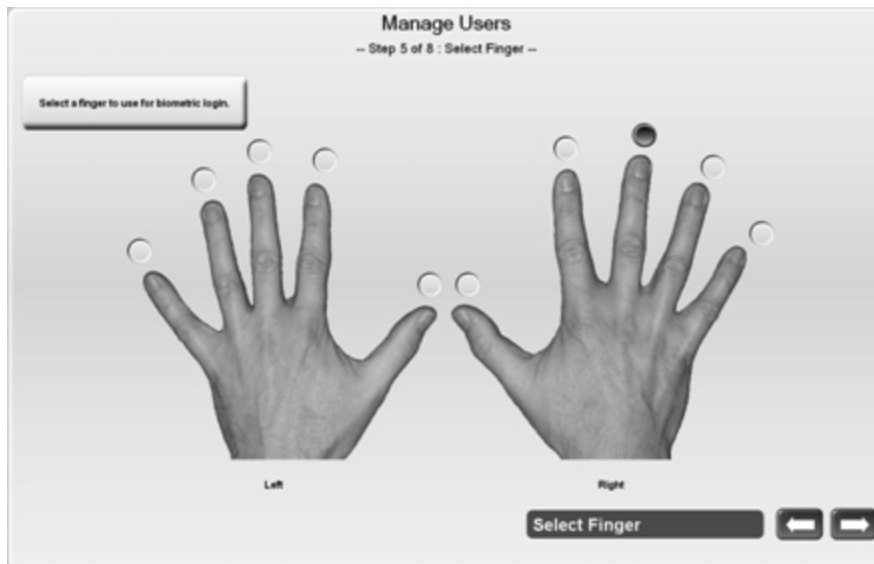

6. [Select Finger] Choose which finger the biometric sensor will read. This finger must be used every time when logging in.
7. [Read Finger] Select the Start button at the top of the screen. Instruct the user to place his or her finger on the biometric sensor three times (for accuracy) when prompted.
8. [Permissions] Select the desired permissions.
9. [Finished]  Select the OK button to save changes and exit.

Export Users

Export user accounts from one system to another, or back up your user accounts.



What you need:

- A USB device
- Administrator access

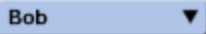
To export a user account:

1. Insert the USB device into an available slot on the Intellispec system.
2.  Select the button with your user name | Export Users.



3. Select the user account that you want to export.
4.  Select the right arrow to export the user account.
5. Choose the destination to save the user account from the drop-down menu, or select the disk icon to browse to the USB device.
6.  Select the OK button to save changes and exit. The user account is exported.

Import Users

Import user accounts from one system to another, or from a backup USB device.



What you need:

- A USB device with user accounts already saved on it, or a folder on the Intellispec hard drive with valid user accounts
- Administrator access

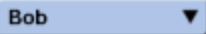
To import a user account:

1. Insert the USB device into an available slot on the Intellispec system.
2.  Select the button with your user name | Import Users.





3. Select the user account that you want to import from the right column. If you do not see any users available, select the disk icon to browse to a location where the user account is saved.
4.  Select the left arrow to import the user account.
5.  Select the OK button to save changes and exit. The user account is imported.

Set Up Auto Logout

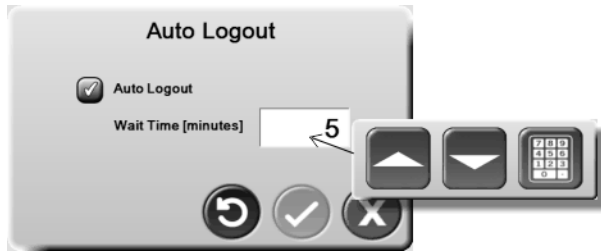
This feature will automatically log out any user after a number of minutes of inactivity.



To set up Auto Logout:

1. Log in.
2.  Select the button with your user name.
3. Select Setup Auto Logout. The setup menu is displayed.
4. Enable Auto Logout. A check mark is displayed in the box when it is enabled.
5. Set the Wait time in minutes (from 1 to 9999 minutes).
6.  Select the OK button to save changes and exit. All users will be logged out automatically after the set number of minutes of inactivity.

Module 4 System Tools

In this section:

Log Reader	40
Reporting	41
Alarms	45
Rejecting	63
Support Package	68
Save Images	73

Log Reader

	Date	Time	Lane	Message	User	Online	Part Program	AI
Tue	2011-11-22	17:03:05	(2) Nicke	System went offline.	Administrator	Offline	Nickel	R
Tue	2011-11-29	09:27:47	(0) System	System process starts.	Administrator	Offline	default	
Tue	2011-11-29	09:28:18	(0) System	Internal Error	Administrator	Offline	default	
Tue	2011-11-29	09:28:31	(4) Quarter	Lane process starts.	Administrator	Offline	Measurement_test	
Tue	2011-11-29	09:28:31	(4) Quarter	Version: 5.0.467 (XP, 32 bit)	Administrator	Offline	Measurement_test	
Tue	2011-11-29	09:28:31	(4) Quarter	Built: 11/28/2011 3:29:07 PM	Administrator	Offline	Measurement_test	
Tue	2011-11-29	09:28:31	(4) Quarter	Built by: dpaunescu	Administrator	Offline	Measurement_test	
Tue	2011-11-29	09:28:31	(4) Quarter	Built on machine: DPOP755	Administrator	Offline	Measurement_test	
Tue	2011-11-29	09:28:31	(4) Quarter	Built on operating system: Microsoft Windows NT 5.1.2600 Service ...	Administrator	Offline	Measurement_test	
Tue	2011-11-29	09:28:31	(4) Quarter	Build changed from '5.0.465 (XP, 32 bit)' to '5.0.467 (XP, 32 bit)'	Administrator	Offline	Measurement_test	
Tue	2011-11-29	09:28:31	(2) Nicke	Lane process starts.	Administrator	Offline	Nickel	R
Tue	2011-11-29	09:30:20	(2) Nicke	Sensor 'Neck' with Id 2 in the part program 1L squat blue was not fou...	Administrator	Offline	Nickel	
Tue	2011-11-29	09:30:20	(2) Nicke	Sensor 'Seal' with Id 3 in the part program 1L squat blue was not fou...	Administrator	Offline	Nickel	
Tue	2011-11-29	09:30:20	(2) Nicke	Sensor 'Neck' with Id 2 in the part program .5L Snapple Clear was n...	Administrator	Offline	Nickel	
Tue	2011-11-29	09:30:20	(2) Nicke	Sensor 'Seal' with Id 3 in the part program .5L Snapple Clear was no...	Administrator	Offline	Nickel	
Tue	2011-11-29	09:30:22	(0) System	Was not able to connect to a UPS	Administrator	Offline	default	
Tue	2011-11-29	09:30:41	(0) System	User 'Administrator' has logged in.	Administrator	Offline	default	
Tue	2011-11-29	09:32:03	(2) Nicke	System went offline.	Administrator	Offline	Nickel	
Tue	2011-11-29	09:41:35	(1) Penny	System went online.	Administrator	Online	Penny	
Tue	2011-11-29	09:41:36	(1) Penny	System went offline.	Administrator	Offline	Penny	



To get to this menu: select Home | Tools | Log Reader.

The log reader displays the Intellispec event history including:

- User log in and log out information
- Notification when the part program was changed. Note: detailed changes to parameters and program changes are found in the Part Program Change Log
- Alarms, when triggered and cleared
- System errors
- System starting information
- Lane online/ offline history
- Lighting changes
- Reports generated
- Text files of the logs are stored at: C:\Pressco\Logs.

Reporting

The Intellispec generates many different reports to provide inspection detail. Many of these reports can be transferred outside of the Intellispec.

Note: Some menu items are only available to advanced level users.

  To view reports: Select a Lane button | Tools | Reporting.

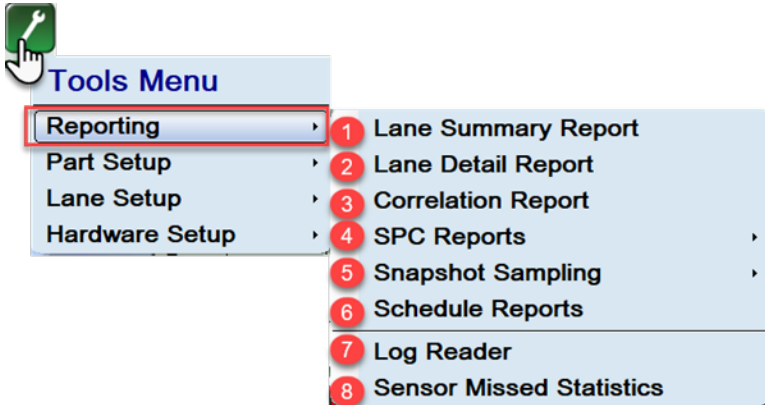

1 and 2 - "Lane Summary and Lane Detail reports" on the next page

3 - "Correlation Report" on page 43

4 - SPC Reports (SPC = Statistical Process Control)

5 - **Snapshot Sampling** - Snapshot sampling allows you to generate statistics for a limited number of future parts (up to 1,000,000). You can sample defect images (up to 1,000 per camera) and good images (up to 1,000 per camera).

6 - "Schedule Reports" on page 44

7 - Log Reader

8 - **Sensor Missed Statistics** - Displays the number of missed parts and missed part tracking for the sensor.

(not shown)- **Defect Data Viewer** - [if enabled] view the images in the defect database

(not shown)- **Defect Database** - [if enabled] view the inspection data from the defect database

Lane Summary and Lane Detail reports

Lane Summary Report

This report lists the statistics for the lane, including:

- Number of parts inspected
- Number of defects
- Defect percentage

The above numbers are reported per sensor, and as an overall number for the lane. An example from a one lane system is shown below.

Inspection	Parts	Defects	Defect %	Last N	Last N %
BNS	3456	1614	46.701	0	0.000
Base	3456	692	20.023	0	0.000
Sensor	3456	231	6.684	0	0.000
Seal	3456	691	19.994	0	0.000

Lane Detail Report

This report contains all the information in the Lane Summary Report, plus inspection detail for each sensor.

Inspection	Parts	Defects	Defect %	Last N	Last N %
BNS	3456	1614	46.701	0	0.000
Base	3456	692	20.023	0	0.000
Empty Pocket ROI	3456	0	0.000	0	0.000
Empty Pocket	3456	0	0.000	0	0.000
True Center ROI	3456	0	0.000	0	0.000
True Center	3456	0	0.000	0	0.000
Outer Base ROI	3456	0	0.000	0	0.000
Outer Base Inspection	3456	231	6.684	0	0.000
Spoke Defects ROI	3456	0	0.000	0	0.000
Black and white	3456	0	0.000	0	0.000
Clipping	3456	0	0.000	0	0.000
Orientation ROI	3456	0	0.000	0	0.000
Orientation	3456	0	0.000	0	0.000
Foot ROI	3456	0	0.000	0	0.000
Foot Inspection	3456	462	13.368	0	0.000
Between Foot ROI	3456	0	0.000	0	0.000
Between Foot Inspection	3456	0	0.000	0	0.000
Pearling ROI	3456	0	0.000	0	0.000
Pearling Inspection	3456	0	0.000	0	0.000
Gate Registration ROI	3456	0	0.000	0	0.000
Gate Registration	3456	0	0.000	0	0.000
Gate ROI	3456	0	0.000	0	0.000
Gate Inspection	3456	0	0.000	0	0.000
Around Gate ROI	3456	0	0.000	0	0.000
Around Gate Inspection	3456	231	6.684	0	0.000
Base Fold Inspection	3456	0	0.000	0	0.000
off-Center Gate Inspection	3456	230	6.655	0	0.000

Correlation Report

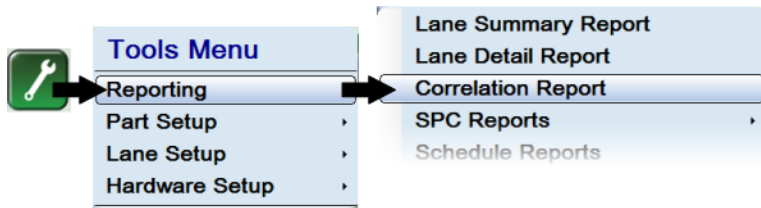

This report contains the percentage of defects by machine part, sorted from highest to lowest percentage of failure.

The image shows a Notepad window titled 'Report - Notepad'. The window contains the following text:

```
File Edit Format View Help
Machine Name: TT3400
Part Program: FHCP3X Master
Current Time: 6/18/2013 1:28:37 PM
Last Reset: 6/18/2013 9:42:47 AM

'FILLER VALVE'
# Percent
28 0.18
112 0.18
136 0.18
16 0.18
76 0.18
88 0.18
100 0.18
52 0.18
40 0.18
64 0.18
124 0.17
4 0.17
144 0.16
60 0.16
24 0.16
36 0.16
96 0.16
84 0.16
108 0.16
120 0.16

'CAPPER HEAD'
# Percent
28 0.71
16 0.71
4 0.71
24 0.64
36 0.64
12 0.63
20 0.51
22 0.51
8 0.5
34 0.5
10 0.5
32 0.5
18 0.45
30 0.45
6 0.44
13 0.42
19 0.42
25 0.42
1 0.41
7 0.41
31 0.41
15 0.34
~ ~
```

Schedule Reports

Set up a schedule where the Intellispec generates reports automatically. This is a Lane-level setting. To schedule reports for more than one lane, you must repeat the process for each lane. To access: select from Lane Overview: Tools | Reporting | Schedule Reports.

The screenshot shows the 'Schedule Reports' dialog box. At the top, there is a dropdown menu (1) set to '✓Lane Summary Report' and a checked checkbox (2) for 'Enable Scheduled Report'. Below this is a green-bordered area containing several options: a dropdown menu (3) set to 'Text File', a 'File Name' button, a 'Keep File Name' checkbox (4), a 'Clear Statistics' checkbox (5), a 'Next Scheduled Report' field (6) showing '0:00 Tomorrow', and a 'Time Between Reports' field (7) showing '12 hours' and '0 minutes'. To the right of this area are four checkboxes: 'Print on Change-Over' (9), 'Print on Shutdown' (10), 'Print on Clear Statistics' (11), and 'Print on Shutdown Clear Statistics' (12). At the bottom of the green area is a 'Preview' button (8). At the bottom right of the dialog are a green checkmark button and a red 'X' button.

- 1 - Report drop-down menu
- 2 - Enable Scheduled Report
- 3 - Destination drop-down menu
- 4 - Keep File Name
- 5 - Clear Statistics
- 6 - Next Scheduled Report
- 7 - Time Between Reports
- 8 - Preview
- 9 - Print on Change-Over
- 10 - Print on Shutdown
- 11 - Print on Clear Statistics
- 12 - Print on Shutdown Clear Statistics

Types of Alarms

There are five types of alarms: System, Lane, Sensor, Rejector, and Machine Part alarms. Most of these are configurable (except the System Alarms - UPS and over temperature).

Note: Alarms are recorded in the system log reader, even when the alarms are automatically cleared.

View and Clear Alarms

ALARM





To View or Clear Alarms, select an Alarm button. If no alarm is active, click the Alarms icon | View/Clear Alarms.

Select the Clear button to clear a single alarm, or the Clear All button to clear all alarms, including alarms in other tabs.

Select different tabs to see more alarms. The tabs (except Lane) have sub-tabs. If any alarm is raised in a sub-tab (Sensor 1 in our example), then the container tab (Sensor) also shows an alarm.

Select any indicator to see alarm details. You can also do this if an alarm is not active.

The indicators in this screen show whether an alarm is enabled, and whether it is triggered.

-  Red On - the alarm is both enabled and triggered
-  Green On - the alarm is enabled, but has not been triggered
-  Green Off - the alarm is not enabled nor triggered

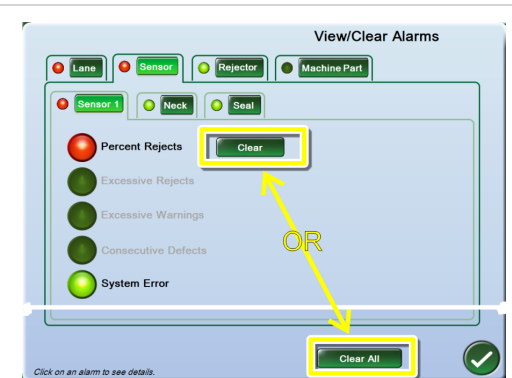

View and Clear Machine Part Alarms



From the alarms button | View/ Clear Alarms | Machine Part:

View/Clear Alarms

Machine Part

Correlation Alarm Details
InFeed

2. Excessive Rejects

Alarm triggers at percent: 2
Sample Size: 100

Next Triggered Item

1.	2.	3.	4.	Item	Parts	Failed	Failed %	When
●	●	●	●	1	100	4	4	15:50:37.669
●	●	●	●	2	100	4	4	15:50:37.813
●	●	●	●	3	100	3	3	15:50:35.522
●	●	●	●	15	100	4	4	15:50:36.937
●	●	●	●	16	100	4	4	15:50:37.057

Update

Clicking on any machine part alarm shows a details table breaking the alarm details down per correlation value (aka machine part item).

The table lets you select any of the (enabled) alarms either by using the drop down or by clicking one of the columns 1., 2., 3., etc.

A "Next Triggered Item" navigator helps to quickly find the item in alarm when all machine parts cannot be displayed simultaneously.

The Update button updates current inspection information (how many parts have currently been processed and how many failed; this is automatically done if an alarm is raised while in this view).

Review Alarm Configurations



You can view all the alarm setups from one screen. Access this screen from the alarms button | Review Alarm Configurations, in Lane or Sensor Overview.

Review Configurations for All Alarms

Lane **#1 (LANE)** Source Type **All** Activation **Hide Disabled**

Light Tree *Extended I/O*

Lane	Source	Alarm	Activation	Visual	Audible	Digital Out	
#1 (LANE)	Lane	Percent Defects	Warning	3600 s	3600 s	0x2 (Bit 1)	
#1 (LANE)	Lane	System Error	Warning	10 s	2 s	-	
#1 (LANE)	Sensor 1	Main	Percent Rejects	Warning	3600 s	3600 s	0x2 (Bit 1)
#1 (LANE)	Sensor 1	Main	Consecutive Defects	Warning	3600 s	3600 s	0x2 (Bit 1)
#1 (LANE)	Sensor 1	Main	System Error	Warning	10 s	2 s	-
#1 (LANE)	Sensor 2	Color 1	Percent Rejects	Warning	3600 s	3600 s	0x2 (Bit 1)
#1 (LANE)	Sensor 2	Color 1	Consecutive Defects	Warning	3600 s	3600 s	0x2 (Bit 1)
#1 (LANE)	Sensor 2	Color 1	System Error	Warning	10 s	2 s	-
#1 (LANE)	Sensor 3	Color 2	Percent Rejects	Warning	3600 s	3600 s	-
#1 (LANE)	Sensor 3	Color 2	System Error	Warning	10 s	2 s	-
#1 (LANE)	Rejector 1		Jam at Reject Confirm	Warning	3600 s	3600 s	-
#1 (LANE)	Rejector 1		Missed Reject	Warning	10 s	2 s	-
#1 (LANE)	Rejector 1		Missed Result	Warning	10 s	2 s	-
#1 (LANE)	MP1	Filler Valve	Percent Rejects	Warning	3600 s	3600 s	-
#1 (LANE)	MP2	Capper Head	Percent Rejects	Warning	3600 s	3600 s	-
#1 (LANE)	MP2	Capper Head	Excessive Rejects	Warning	3600 s	3600 s	-

Use the drop-down menus at the top of the screen to filter what you want to see. For example, view the alarm setups for only the Sensors, through the Source drop-down.

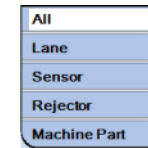

Sort data by column, by selecting a button at the top of the table. For example, sort the alarms alphabetically by sensor/machine part name, by clicking the blank button.

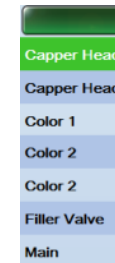

System Alarms - Description and Configuration

The system alarms are the UPS (uninterruptible power supply) and CPU temperature alarms. You can configure the UPS shut down time. These are only shown in the System Overview and will not show up as flashing lane buttons, or on any light tree, and will not sound a horn.

Alarm	Description	Action
UPS	Battery is dead. Or: Plant power is lost and the UPS shutdown time is exceeded. The Intellispec shuts down.	Replace battery Automatically resets If plant power is restored before the Intellispec shuts down, then the alarm is automatically cleared. Otherwise, restart the system.
Over temperature	CPU temperature exceeds highest recommended operating temperature. The Intellispec system shuts down. You must wait till the processor cools before resuming operation.	

System Alarm Setup



To get to this menu: select Home | Alarms.

System Alarms

1 → UPS Shutdown Time (sec) 120

2 → CPU Temperature Warning Level (°C) 88

→ CPU Temperature Shutdown Level (°C) 96

→ CPU Temperature Current Value (°C) 46

















✓ X

1 - **UPS Shutdown Time** - The number of seconds that the UPS will maintain power to the system if AC power has been lost. The Intellispec system shuts down after this time period. This allows for a normal Windows shutdown.

2 - **CPU Temperature** - If a multiple core computer is used, the highest temperature is displayed. If the shutdown CPU temperature is reached, the Intellispec system shuts down.

Lane Alarms - Brief Description

The Lane Alarms affect the hardware associated with one lane. A lane usually refers to one production line, and can contain multiple sensors.

Alarm	Description	Action	4-Light Tree ²	5-Light Tree ²
Percent Defects ¹	Percentage of defects exceeds the set limit.	Check the production line to see what might be creating too many bad parts Reset alarm on screen	 Red	 Red
Offline ¹	Lane goes offline	Automatically resets	 Green = system is online  Red = system is offline	 Green = system is online  Red = system is offline
Chute Full ¹	Reject chute is full	Clear chute Reset alarm on screen	 Red	 Red
Power Status ¹	Lane AC Power is lost	Automatically resets Troubleshoot: Check that the inspection module power switch is on. Check +24V supply.	 Red = AC power is lost  Blue = power is OK	 Red = AC power is lost  White = power is OK
Good Parts ¹	Used as a part counter. When specified number of parts is reached, then alarm is triggered.	Replace the box with counted parts with an empty box, then clear alarm. Reset alarm on screen	 Red	 Red
System Error ¹	Part tracker or other internal system errors	Depends on specific alarm (see details for System Error Alarm) Reset alarm on screen	 Red Red Flashing for Part Tracker Lost Communication	 Red Red Flashing for Part Tracker Lost Communication

¹ If you want to connect an external monitoring device such as a PLC, an optional Extended I/O board is required for each lane.

² The light tree displays this color for the Duration if Visual Enabled.

Lane Alarm Configuration

 Set up alarms for a lane. To get to this menu: From Lane Overview mode, select Alarms | Lane Alarm Configuration. Select an alarm from the drop-down menu to configure that alarm. Enabled = checked.

Note: Some menu items are only available to advanced level users.

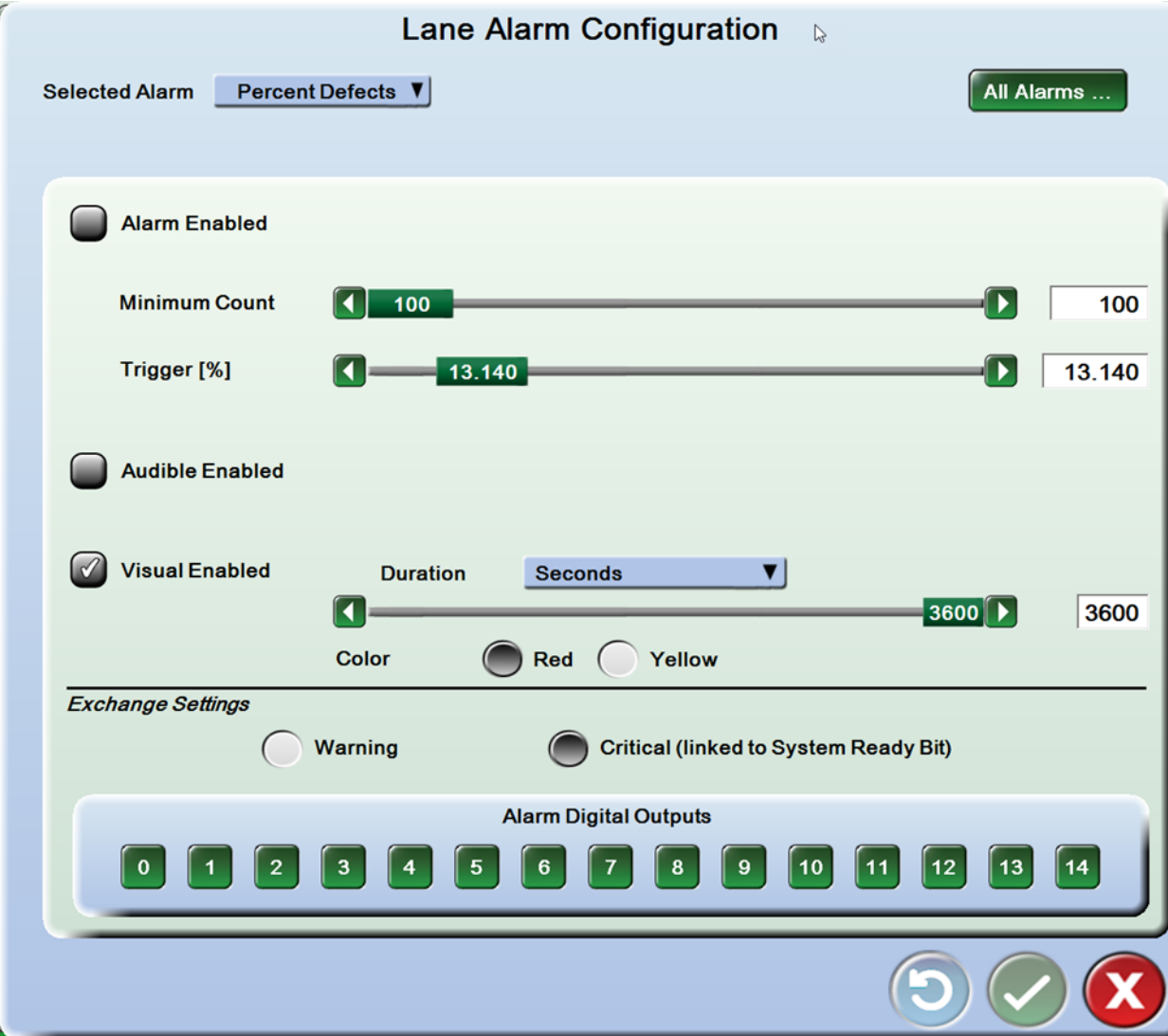

Lane Alarm Configuration

Selected Alarm: **Percent Defects** All Alarms ...

Alarm Enabled

Minimum Count: 100

Trigger [%]: 13.140

Audible Enabled

Visual Enabled

Duration: **Seconds** 3600



Color: Red Yellow

Exchange Settings

Warning Critical (linked to System Ready Bit)





Alarm Digital Outputs

0 1 2 3 4 5 6 7 8 9 10 11 12 13 14

Sensor Alarms - Brief Description

Sensor alarms are configured for each sensor (camera or other sensor).

Alarm	Description	Action	Light Tree ²
Percent Rejects ¹	Percent Rejects - This alarm is triggered when the Trigger [%] is exceeded. It will remain triggered until you clear the alarm.	Check the production line to see what might be creating too many bad parts Reset alarm on screen	 Red
Excessive Rejects ¹	Excessive Rejects - This alarm is triggered when Trigger [%] of the last Sample Size parts have been found defective. It will remain triggered until you clear the alarm.	Check the production line to see what might be creating too many bad parts Reset alarm on screen	 Red
Excessive Warnings ¹	Excessive Warnings - This alarm is triggered when Trigger [%] of the last Sample Size parts have been found with a warning status. It will remain triggered until you clear the alarm. Warnings are enabled in the Retro-Spec Options when you are editing an inspection. They can also be enabled in Lane Setup Select Features.	Check the production line to see what might be creating too many bad parts Reset alarm on screen	 Amber
Consecutive Defects ¹	Consecutive Defects - This alarm is triggered when Consecutive Triggers has been exceeded [the sensor had too many consecutive defects]. It will remain triggered until you clear the alarm.	Check the production line to see what might be creating too many bad parts Reset alarm on screen	 Red
Mass Lighting	Mass Lighting - This alarm is triggered when the lighting threshold falls below a minimum level.	Clean the mass sensors and emitters Reset alarm on screen	none
System Error ¹	Missed part, missed acquisition, missed result, or other internal error	Reset alarm on screen	 Red

¹ If you want to connect an external monitoring device such as a PLC, an optional Extended I/O board is required for each lane.

² The light tree displays this color for the Duration if Visual Enabled.

Sensor Alarm Configuration

 Set up alarms for a Sensor. To get to this menu: From Lane or Sensor Overview mode, select Alarms | Sensor Alarm Configuration. Choose a sensor to configure. You must configure each sensor separately.

Select an alarm from the drop-down menu to configure that alarm. Enabled = checked.

Some menu items are only available to advanced level users.



Sensor Alarm Configuration *Apply alarm to:*

Sensor **Base**

Selected Alarm **Percent Rejects** **All Alarms ...**

Alarm Enabled

Minimum Count **100** **100**

Trigger [%] **0.500** **0.500**

Audible Enabled Duration **Seconds** **5** **5**

Visual Enabled Duration **Seconds** **45** **45**

Color Red Yellow

Exchange Settings

Warning Critical (linked to System Ready Bit)



Alarm Digital Outputs

0 1 2 3 4 5 6 7 8 9 10 11 12 13 14

Rejector Alarms - Brief Description

Rejector Alarms are triggered when a part did not get rejected as expected.

Alarm	Description	Action	Light Tree ²
Jam at Reject Confirm ¹	The reject confirm path has been blocked too long. Works with Reject Confirm Calibration (Optional)	Remove jammed parts at the rejecter, then clear alarm. Reset alarm on screen	 Red
Missed Reject ¹	System missed rejecting a part. Works with Reject Confirm Calibration (Optional)	Reset alarm on screen	 Red
Missed Result ¹	The part reached the rejector before the part was fully inspected and the result was sent to the part tracker. That is, the inspections took too long to run.	If this occurs often, look at the inspection settings. It may be possible to use other settings to reduce inspection time. Reset alarm on screen	 Red

¹ If you want to connect an external monitoring device such as a PLC, an optional Extended I/O board is required for each lane.

² The light tree displays this color for the Duration if Visual Enabled.

Rejector Alarms Configuration

 Set up alarms for rejecting. To get to this menu: From Lane Overview mode, select Alarms | Rejector Alarm Configuration.

Select an alarm from the drop-down menu to configure that alarm. Enabled = checked.

Note: Some menu items are only available to advanced level users.



The dialog box is titled "Rejector Alarm Configuration". At the top left, it shows "Selected Alarm" with a dropdown menu set to "Jam at Reject Confirm". To the right is a green button labeled "All Alarms ...".

The main configuration area has three sections:

- Alarm Enabled:** A checkbox that is currently unchecked.
- Audible Enabled:** A checked checkbox. Below it is a "Duration" dropdown set to "Seconds" and a slider control. The slider is positioned at 3600, with a green box containing "3600" and a corresponding text box to the right.
- Visual Enabled:** A checked checkbox. Below it is a "Duration" dropdown set to "Seconds" and a slider control. The slider is positioned at 3600, with a green box containing "3600" and a corresponding text box to the right.

Below the duration settings is a "Color" section with two radio buttons: "Red" (selected) and "Yellow".

A horizontal line separates the main settings from the "Exchange Settings" section, which contains two radio buttons: "Warning" and "Critical (linked to System Ready Bit)".





At the bottom is the "Alarm Digital Outputs" section, which consists of a row of 15 green buttons numbered 0 through 14.

At the bottom right of the dialog are three circular buttons: a refresh button (circular arrow), a confirmation button (checkmark), and a cancel button (red circle with an X).

Machine Part Alarms - Brief Description

Machine Part alarms are the correlation-based alarms. They are visible only if your system has correlation sensors installed.

Note: for Machine Part Alarms, except Correlation Out of Range, statistics apply to each correlation value separately. That is, if one of 100 machine parts fails at 100 percent, the detected percentage is 100 percent while overall it would be 1 percent.

Alarm	Description	Action	Light Tree ²
Percent Rejects ¹	Percent Rejects - This alarm is triggered when the Trigger [%] is exceeded. It will remain triggered until you clear the alarm.	Check the production line to see what might be creating too many bad parts Reset alarm on screen	 Red
Excessive Rejects ¹	Excessive Rejects - This alarm is triggered when Trigger [%] of the last Sample Size parts have been found defective. It will remain triggered until you clear the alarm.	Check the production line to see what might be creating too many bad parts Reset alarm on screen	 Red
Excessive Warnings ¹	Excessive Warnings - This alarm is triggered when Trigger [%] of the last Sample Size parts have been found with a warning status. It will remain triggered until you clear the alarm. Warnings are enabled in the Retro-Spec Options when you are editing an inspection. They can also be enabled in Lane Setup Select Features.	Check the production line to see what might be creating too many bad parts Reset alarm on screen	 Amber
Consecutive Defects ¹	Consecutive Defects - This alarm is triggered when Consecutive Triggers has been exceeded [the sensor had too many consecutive defects]. It will remain triggered until you clear the alarm.	Check the production line to see what might be creating too many bad parts Reset alarm on screen	 Red
Correlation Out of Range	Correlation Out of Range - This alarm is triggered if the part tracker counts a machine part that was not configured.	Reset alarm on screen	 Red

¹ If you want to connect an external monitoring device such as a PLC, an optional Extended I/O board is required for each lane.

² The light tree displays this color for the Duration if Visual Enabled.

Machine Part Alarms Configuration

 Set up alarms for machine parts. To get to this menu: From Lane Overview mode, select Alarms | Machine Part Alarm Configuration. Select an alarm from the drop-down menu to configure that alarm. Enabled = checked.

Note: Some menu items are only available to advanced level users.

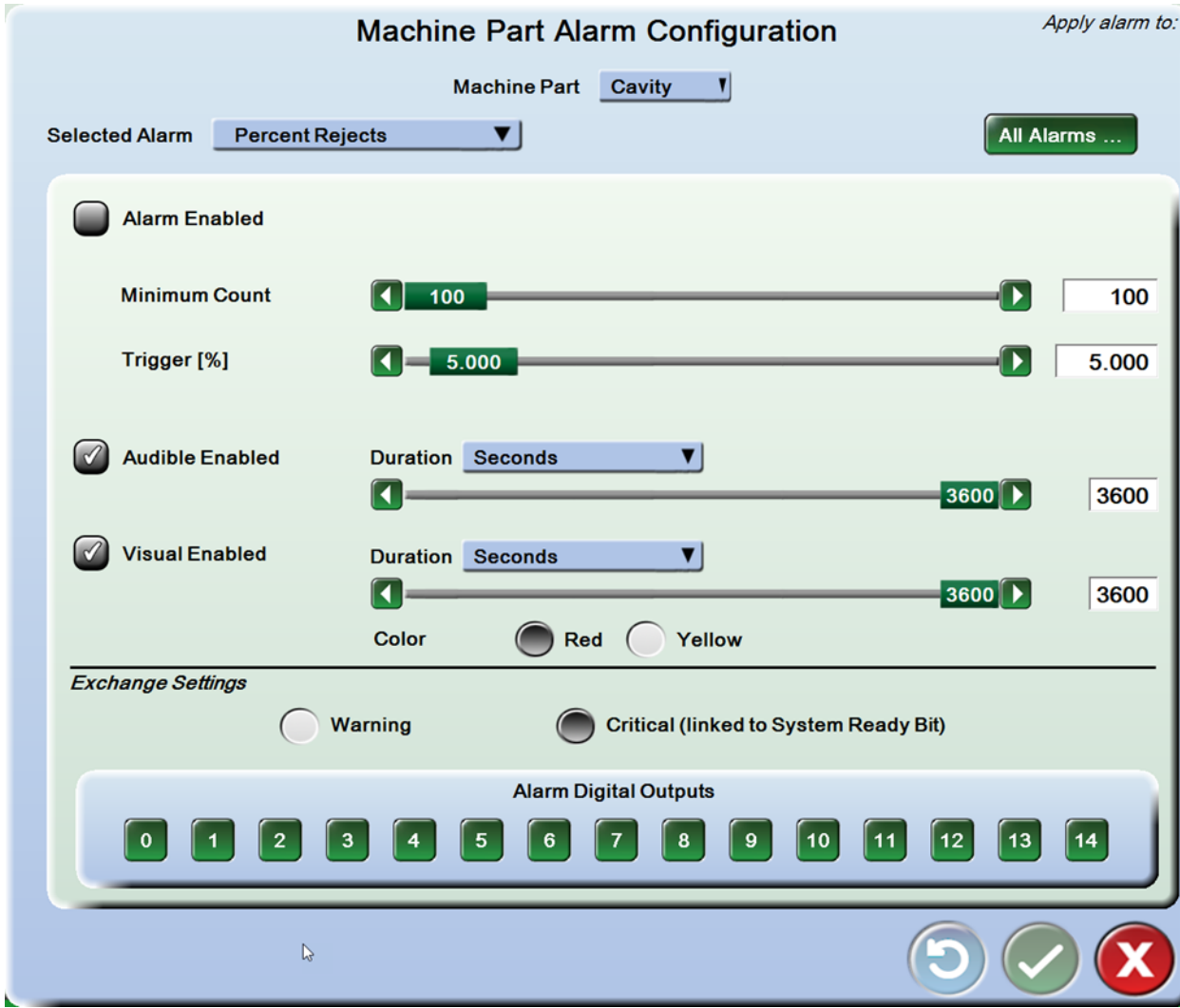

The interface is titled "Machine Part Alarm Configuration" and includes a sub-header "Apply alarm to:". Below this, there is a "Machine Part" dropdown menu set to "Cavity" and a "Selected Alarm" dropdown menu set to "Percent Rejects". A green "All Alarms ..." button is located to the right of the "Selected Alarm" menu.

The main configuration area contains several sections:

- Alarm Enabled:** A checkbox that is currently unchecked.
- Minimum Count:** A slider control with a value of 100.
- Trigger [%]:** A slider control with a value of 5.000.
- Audible Enabled:** A checked checkbox. Below it is a "Duration" dropdown menu set to "Seconds" and a slider control with a value of 3600.
- Visual Enabled:** A checked checkbox. Below it is a "Duration" dropdown menu set to "Seconds" and a slider control with a value of 3600.
- Color:** Two radio buttons, "Red" (selected) and "Yellow".
- Exchange Settings:** Two radio buttons, "Warning" (selected) and "Critical (linked to System Ready Bit)".
- Alarm Digital Outputs:** A row of 15 buttons numbered 0 through 14.

At the bottom right of the interface are three circular buttons: a refresh button (circular arrow), a checkmark button, and a close button (red circle with an X).

All Alarms

All Alarms ...

All Alarms button from an alarm configuration window.

Apply the same settings to all alarms on one or all lanes and one or all sources (Sensors, Rejectors, or Machine Parts). For example, you may always want to use the same Visual Duration for all Sensor alarms. This screen applies that setting. (You still have to do it separately for each source type: Lane, Sensor, Rejector, Machine Part.)

Apply to All Alarms For:

Apply the selected settings to all alarms for:
Selected Sensors ▼

Setting Selection	Value Being Set
<input checked="" type="checkbox"/> Alarm Enabled	<input checked="" type="checkbox"/> Enabled
<input checked="" type="checkbox"/> Visual Enabled	<input checked="" type="checkbox"/> Enabled
<input checked="" type="checkbox"/> Visual Duration	<input type="range" value="45"/> 45 Seconds ▼
<input checked="" type="checkbox"/> Color	<input type="radio"/> Red <input type="radio"/> Yellow
<input checked="" type="checkbox"/> Audible Enabled	<input checked="" type="checkbox"/> Enabled
<input checked="" type="checkbox"/> Audible Duration	<input type="range" value="5"/> 5 Seconds ▼
<input checked="" type="checkbox"/> Exchange Settings	<input type="radio"/> Warning <input type="radio"/> Critical (linked to System Ready Bit)
<input checked="" type="checkbox"/> Digital Outputs	<input type="checkbox"/> 0 <input type="checkbox"/> 1 <input type="checkbox"/> 2 <input type="checkbox"/> 3 <input type="checkbox"/> 4 <input type="checkbox"/> 5 <input type="checkbox"/> 6 <input type="checkbox"/> 7 <input type="checkbox"/> 8 <input type="checkbox"/> 9 <input type="checkbox"/> 10 <input type="checkbox"/> 11 <input type="checkbox"/> 12 <input type="checkbox"/> 13 <input type="checkbox"/> 14

Encoder Rate Alarm

This alarm is raised when the encoder rate exceeds a threshold. You can also “see” the encoder rates from this alarm. This feature is available in Intellispec software versions 5.6.017, 5.7.025, 6.0.029 and later.

The Encoder Alarm is a System Error alarm. You can click on the LED of the alarm to get more details.

The screenshot displays the 'System Error Alarms' window for Lane 1. On the left, a vertical list of status indicators includes 'Percent Defects', 'Offline', 'Chute Full', 'Power Status', 'Good Parts', 'Consecutive Bottl', and 'System Error'. The 'System Error' indicator is highlighted with a red LED. The main window lists several alarms, with 'Encoder Rate Too High' at the bottom highlighted by a red LED and a mouse cursor. A 'Clear' button is located to the right of this alarm. An 'Alarm Details' window is open, showing the following information:

Alarm Details	
Encoder Rate Too High	
Cleared	4/13/2020 9:42:06 AM
By	System Startup
Alarm raised:	4/13/2020 10:30:04 AM

At the bottom of the 'Alarm Details' window, there is a 'Show Encoder Rates' button and a green checkmark icon.

Disable or Enable the Rejector for One Sensor

Mechanic level user and higher

If the system is rejecting excessive parts, you can quickly disable the rejector for that camera.

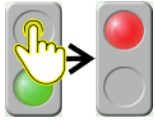

1. Take the lane offline.
2. Right-click a sensor button. Select Rejecting | Sensor Reject Enabled.

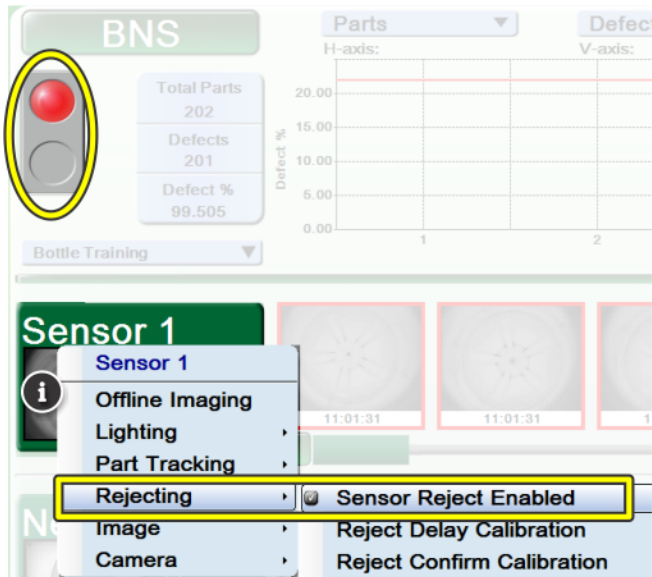

This toggles to Sensor Reject Disabled. Red text = disabled.

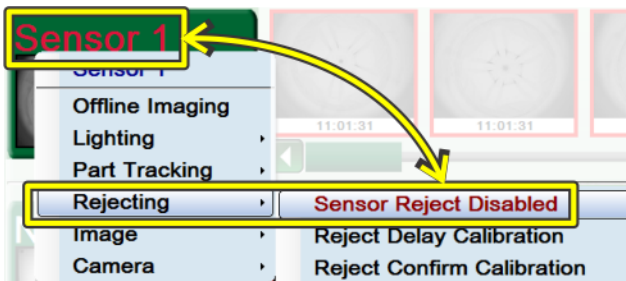

After you have resolved the problem, be sure to Enable the rejector, using the same steps as above. Checked = enabled

Disable or Enable the Rejector for Multiple Sensors

To enable or disable the rejector for one or more sensors within a lane:

 From Lane Overview or Sensor Overview mode, select Tools | Lane Setup | Rejecting | Sensor Reject Enable/Disable. Checked = enabled

Enable Rejecting for Sensor

- Neck
- Flange
- Body
- Dome
- BMID
- Color Dot

All

None

If a rejector is disabled, the sensor name is displayed in red instead of white.



Base
Defects 178
Defect % 19.888

If the rejector for all sensors within the lane is disabled, you will see the trash can icon.

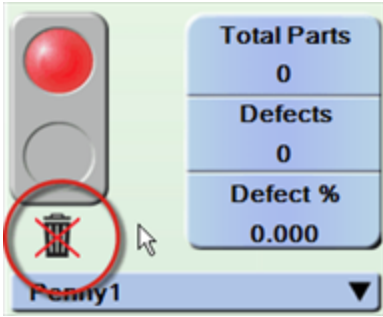

Total Parts	0
Defects	0
Defect %	0.000

Penny1

Disable or Enable the Rejector for an Inspection

Right-click an inspection in the inspection tree. Select Settings | "Is Inspection Reject Enabled?" Make your selection.

The screenshot displays a software interface with a 'Sensor 1' panel on the left. The panel shows 'Defects: 161' and 'Defect %: 100.000'. Below the panel is an 'Inspections' tree with items like 'Empty Pocket' and 'True Center'. A context menu is open over the 'Contrast' inspection, with 'Settings' highlighted. The 'Settings' sub-menu is also open, showing options: 'Is Inspection Enabled?' (Yes checked), 'Is Inspection Reject Enabled?' (Yes checked), 'Is Empty Pocket Check?' (Yes), and 'Exclude from Statistics?' (Yes).

Option	Yes	No
Is Inspection Enabled?	Yes ✓	No
Is Inspection Reject Enabled?	Yes ✓	No
Is Empty Pocket Check?	Yes	No ✓
Exclude from Statistics?	Yes	No ✓

Forced Rejects Utility



To get to this screen: From Lane or Sensor Overview mode, select Tools | Lane Setup | Start Forced Reject.

Note: the lane must be Online to force rejects

Exiting the Forced Rejects utility will not stop the forced reject process. Use the Stop Forced Rejects button.

Forced Reject

1 → Combined Machine Parts

2 → Reject N Parts

3 → Sample Interval

4 → Cavity (1..24)
 Spindle (1..300)
 InFeed (1..24)
 OutFeed (1..24)

5 → Rejector
 1 2

6 → Start Forced Reject

Forced reject won't start until the system is on-line.

Click on a text or number field to edit it.

Status

Forced reject started.
Correlation(Cavity, Spindle, InFeed, OutFeed)
Reject 1 of 9,Correlation(5, 5, 5, 5)
Reject 2 of 9,Correlation(5, 29, 5, 5) Bad Part
Reject 3 of 9,Correlation(5, 53, 5, 5)
Reject 4 of 9,Correlation(5, 77, 5, 5) Bad Part
Reject 5 of 9,Correlation(5, 101, 5, 5)
Reject 6 of 9,Correlation(5, 125, 5, 5)
Reject 7 of 9,Correlation(5, 149, 5, 5)
Reject 8 of 9,Correlation(5, 173, 5, 5)
Reject 9 of 9,Correlation(5, 197, 5, 5) Bad Part
Forced reject completed or stopped.
Forced reject completed.

↑
7

1) Any Part/ Single Machine Part/ Combined Machine Parts/ By Sampling Inspection (drop-down menu)

2) Reject one part, 'N' parts, or continuously reject from a specific machine part.

3) Sample Interval - Only reject parts every n number of intervals.

4) Select Machine Part

5) Rejector - Specify which rejector to force rejection of the part.

6) Start Forced Reject/ Stop Forced Reject

7) Status box - Displays information about the rejection process.

Create a Support Package

A support package is a set of files gathered by the Intellispec system to help find system problems. You will send this package to Pressco service specialists so that they can troubleshoot your system. This file can also back up your system configuration (not the entire system database).

Note: On rare occasions, the Intellispec software cannot be started, so you will not be able to access the support package tool from the user interface. It is possible to create the support package without Intellispec running by starting the following executable from Windows: C:\Pressco\bin\SupportPackaging.exe.

What you need:

- USB flash drive (128MB or larger). Connect this to the USB port
- If you have a ".pcf" file from a Pressco Support representative (to acquire additional system information), then copy that file to the USB drive prior to connecting it to the Intellispec system
- If you want to save images to send with the support file, then save images prior to creating the support file. Be sure to save them in the default image folders: C:\Pressco\Lane n\Images\Sensor n. See Saving Images.

To create the support package:

1.  Select the Backup and Restore Menu | Create Support Package. The support package wizard is displayed.
2. (optional) At Step 1: Configure: add the ".pcf" file or images.

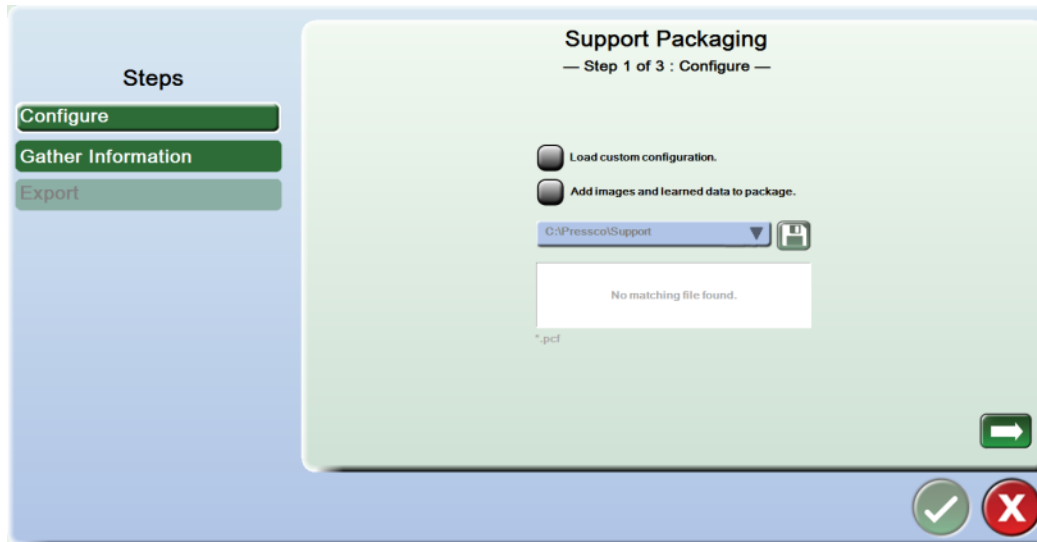

- (optional) Check the Load custom configuration box. A .pcf file is a custom Pressco configuration file that gathers information beyond the standard Support Package. If a Pressco Support representative sent you a .pcf file, then connect the USB device that contains the .pcf file. Select the disk icon and browse to the location (USB drive) where the .pcf file is stored. The system locates the .pcf file.
- (optional) Check the Add images and learned data to package box. A dialog (shown below) allows you to choose the type of images to include.

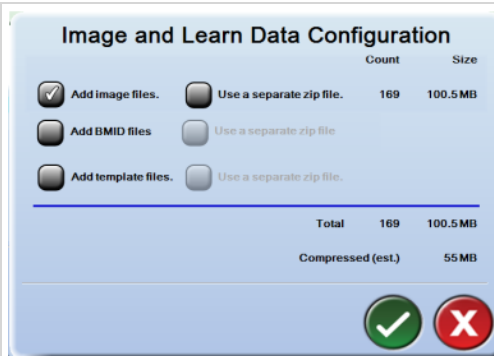

- Add image files** - select images in the default image folder (example: C:\Pressco\Lane 1\Images\Sensor 1). All sensors and lanes for which you have images are included.
 - Use a separate zip file** - a zip file with "IMAGES" in the name is created along with the Support Package zip file. All sensors and lanes for which you have images are included. If you do not check this box, then the images are included in the main Support Package zip file.
 - Add BMID files** - if you have an inspection using BMID correlation, the images from the BMID folder are included (example: C:\Pressco\Lane 1\BMID).
 - Add template files** - if you have a Template Registration or Template Orientation inspection, the images from the InspectionTemplates folder are included (example: C:\Pressco\Lane 1\InspectionTemplates).
- Follow the instructions on screen. Use the forward arrows to move to the next screens.
 - When the steps are completed, verify that the Step 3: Export screen is displayed.

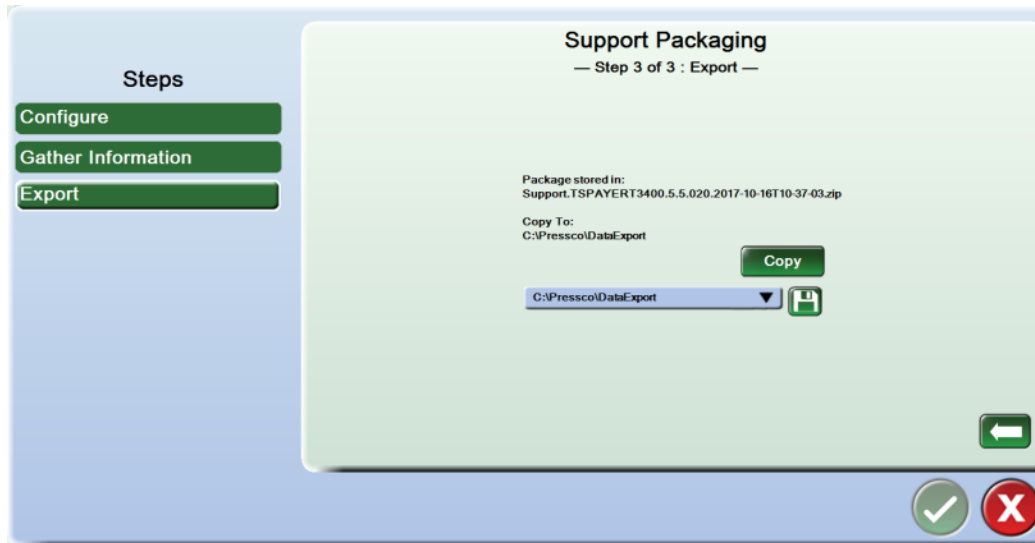

7. Select the USB Flash Drive in the "Copy to:" location.
8. Select the Copy button. The support package files are copied to the USB flash drive, then a "Copy Succeeded" message is displayed.

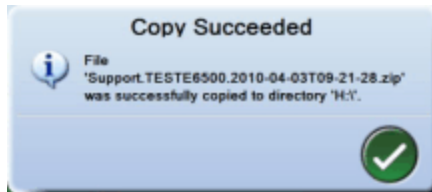

9. Select the OK button to continue.
10. Select the OK button at the bottom of the Support Packaging screen to exit.
11. Remove the USB flash drive.
12. Copy the files that were saved, including images, from the USB drive to your computer.
13. Send an e-mail to techsupport@pressco.com and attach the support package files. Pressco service/ tech support will respond within one business day, if possible.

Restore From Support Package

You can restore (import) a support package to a working Intellispec system. This allows you to use the same configuration on multiple systems without having to duplicate your efforts, or use a known good configuration created on another system or by Pressco Technical Support.

What you need:

A USB flash drive with a known good support package on it

Mechanical keyboard (MKB) to enter a problem description (if backing up your current configuration)

To restore the support package:

1.  Select the Backup and Restore menu | Restore from Support Package.

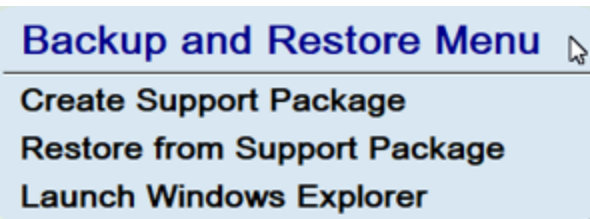

2. The system will suggest that you back up your current system. We recommend that you select the "Create Support File" button to back up the system.
3. Follow the instructions on screen, and select the location of the USB drive that contains the support package you want to restore, when prompted.
4. Select the support package from the USB drive that you want to restore.
5. Use the forward arrows to move to the next screens.
6. When the system says "Series V (or 6) Application detected," select the Stop Application button to shut down the Intellispec software. This is necessary to restore the support package.
7. At step 4 on screen, select the Unpack Zip File button to restore the support package and wait for the system to unpack the files.
8. When the system says "Unpacking Complete," select the forward arrow to move to the next screen.
9. Select the Restart Discovery button to restart the Intellispec application.

Save Images

There are several ways to save an image within the Intellispec system.

Save any image:

In most parts of the system, right-click over any image. Follow the instructions on screen. This is useful to save images to include with a Support Package.

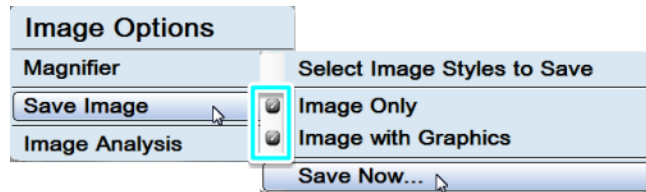

Checked = enabled. Then click Save Now...

Image Only - bitmap (.bmp) image with no graphics. Note: only bitmap images can be loaded back into the Intellispec.

Image with Graphics - portable network graphic (.png) image with inspection graphics

The image is saved to the default location shown, unless you specify a different location. A default file name is provided for you. Select the keyboard icon to rename the image.

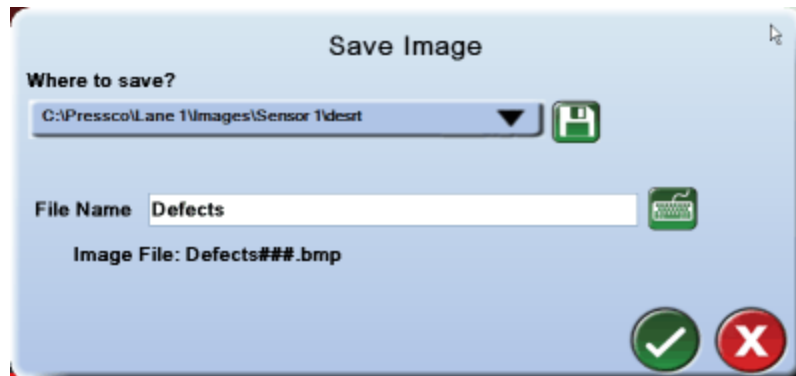

Save Images Through the Sensor Menu

Save a set of images from one sensor (up to 100 images). You can save images whether the lane is online or offline. Right-click to see the menus.

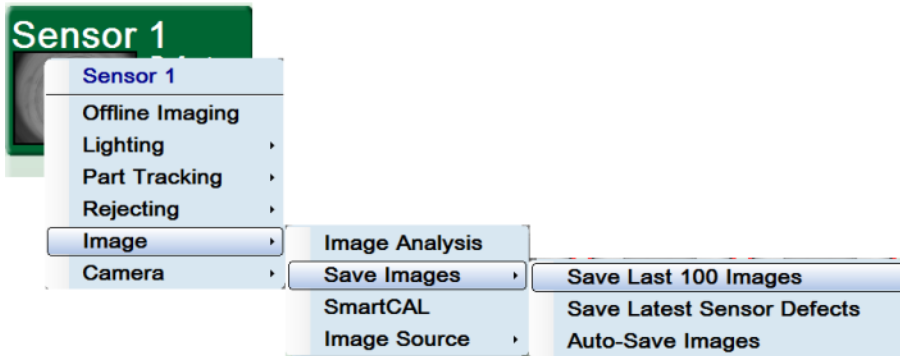

Save Last 100 Images - Save the last 100 images captured by the current sensor.

Save Latest Sensor Defects - Save the latest defect images shown in the Reject Images thumbnails, up to 100 images.

See also "Auto-Save Images" on the next page

Auto-Save Images

Save up to 1000 images from one sensor when the lane is online. To get to this menu: Right-click a sensor button | Image | Save Images | Auto-Save Images.

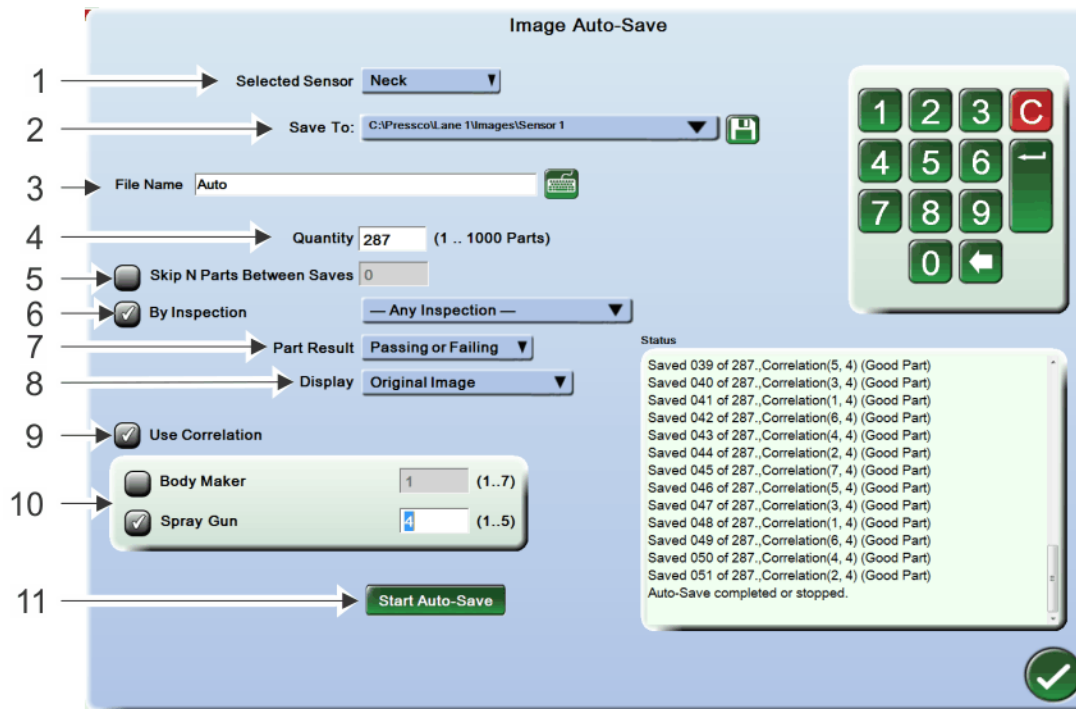

- 1) **Selected Sensor** - Select one or all sensors.
- 2) **Save To** - Select the location. To change the location, select the disk icon and browse to the desired location.
- 3) **File Name** - Create a file name, descriptive of the part you are inspecting. The system automatically adds numbers and letters to the name. Example: "Auto0001_S1_P.bmp." [0001] = image 1. [S1] = Sensor 1. [P] = part passed. [F] = part failed.
- 4) **Quantity** - Quantity of images to auto-save, up to 1000.
- 5) **Skip N Parts Between Saves** - Check the box if you do not want to save consecutive images. Enter the number [N] of parts to skip between saved images.
- 6) **By Inspection** - Only available when you have one sensor selected [in item 1]. Save images related to an inspection. Use the drop-down menu to select the inspection from the current part program.
- 7) **Part Result** - Save images that pass or fail inspection, or both. When images are saved, the file name contains [P] for passing or [F] for failing.

- 8) **Display** - Save the original image from the camera, or the image after centering, or the image after centering and orientation.
- 9) **Use Correlation** - [available if correlation is installed] Save images correlated to specific machine parts.
- 10) **Machine parts** - [available if correlation is installed] Select the machine part(s) to save images from. Also enter a machine part number in the box provided.
- 11) **Start Auto-Save** - Select Start Auto-Save to start saving images. Select Stop Auto-Save to stop the process. The lane must be online to collect images.

Module 5 Lighting and Imaging

In this section:

- Pressco Inspection Theory78**
- Part Tracker Simulation85**
- Imaging86**
- Lighting91**
- Base, Neck, Seal Lighting Adjustments95**

Introduction to Pressco Inspections

What is a pixel? - Pixel (picture element) is the smallest part of a digital image

X/Y Location - All pixels have an X/Y location in an image.

Grayscale - The measured brightness of a pixel from 0 to 255

- 0 = black, the absence of light
- 255 = white, saturated with light

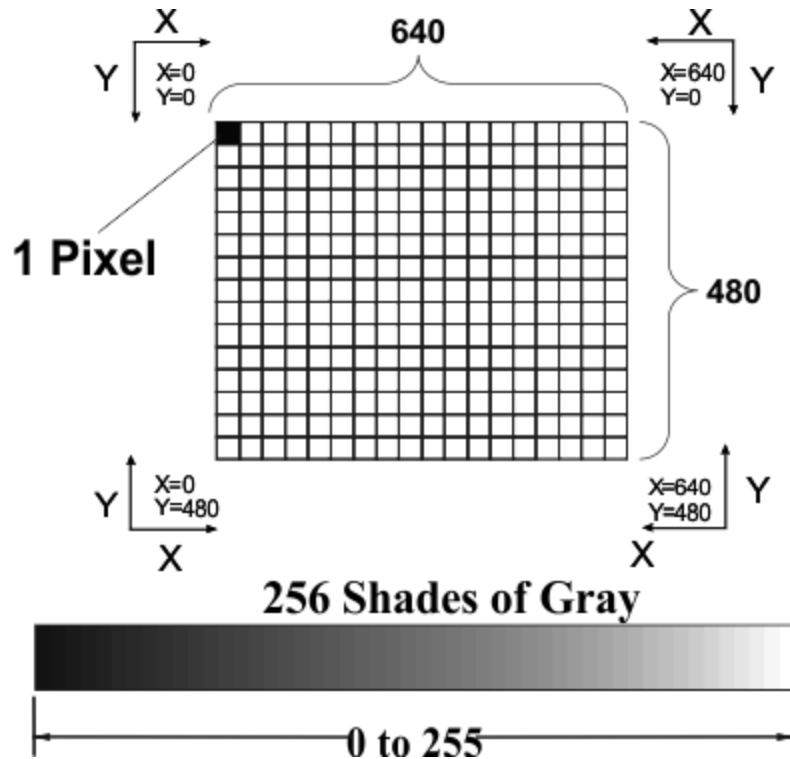

Pixel Grayscale Values

255

255	254	253	252	251	250	249	248	247	246	245	244	243	242	241	240
239	238	237	236	235	234	233	232	231	230	229	228	227	226	225	224
223	222	221	220	219	218	217	216	215	214	213	212	211	210	209	208
207	206	205	204	203	202	201	200	199	198	197	196	195	194	193	192
191	190	189	188	187	186	185	184	183	182	181	180	179	178	177	176
175	174	173	172	171	170	169	168	167	166	165	164	163	162	161	160
159	158	157	156	155	154	153	152	151	150	149	148	147	146	145	144
143	142	141	140	139	138	137	136	135	134	133	132	131	130	129	128
127	126	125	124	123	122	121	120	119	118	117	116	115	114	113	112
111	110	109	108	107	106	105	104	103	102	101	100	99	98	97	96
95	94	93	92	91	90	89	88	87	86	85	84	83	82	81	80
79	78	77	76	75	74	73	72	71	70	69	68	67	66	65	64
63	62	61	60	59	58	57	56	55	54	53	52	51	50	49	48
47	46	45	44	43	42	41	40	39	38	37	36	35	34	33	32
31	30	29	28	27	26	25	24	23	22	21	20	19	18	17	16
15	14	13	12	11	10	9	8	7	6	5	4	3	2	1	0

0

Examples of Grayscale

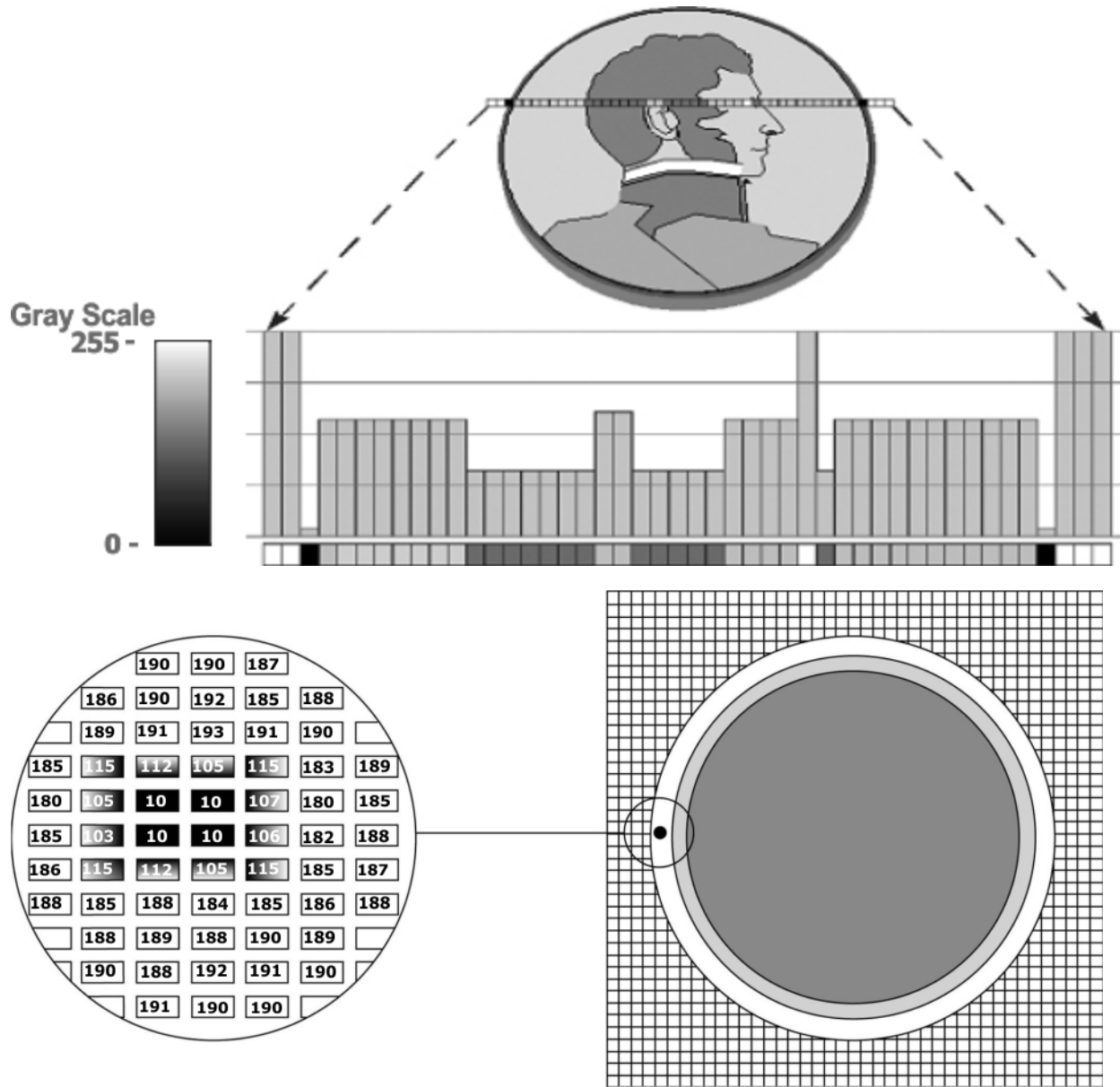

Gradient

The difference in gray shades between pixels being compared.

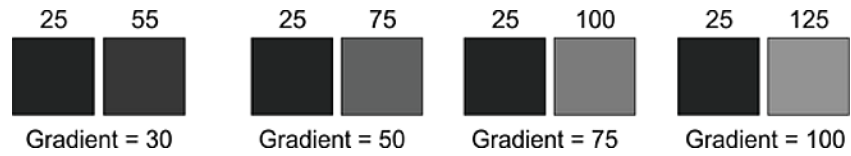

The illustration below shows the same gradient values as above, but displayed as an example 'defect.' In each case, the background is the same - 25 gray shade.

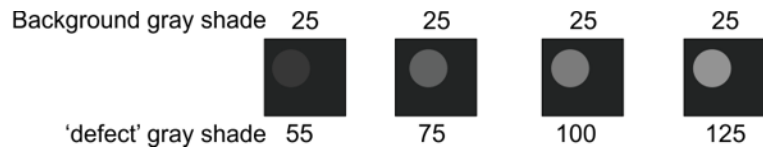

Delta

The distance between pixels being compared. Higher delta = greater sensitivity.

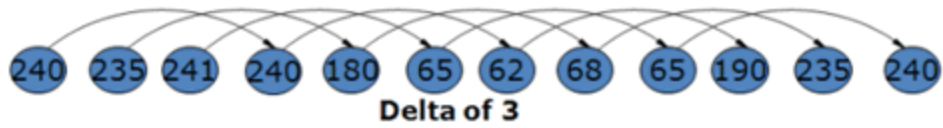
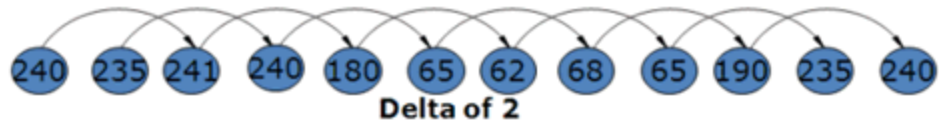

Size

The number of pixels in a group being compared. Greater size = lower sensitivity.

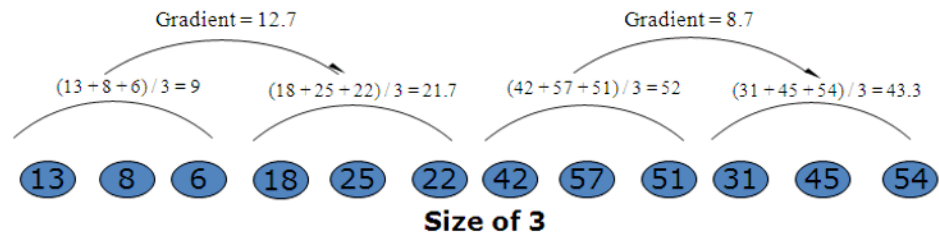
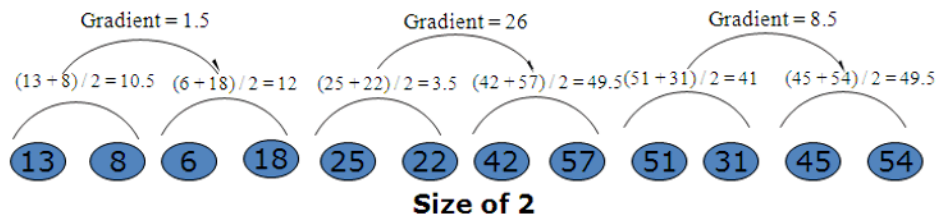

Part Tracker Simulation

Used for troubleshooting. A simulated part rate allows inspection to continue.

 To get to this screen: From Lane or Sensor Overview mode, select Tools | Hardware Setup | Part Tracker Simulation. Select the desired check box(es) and then enter the desired values.

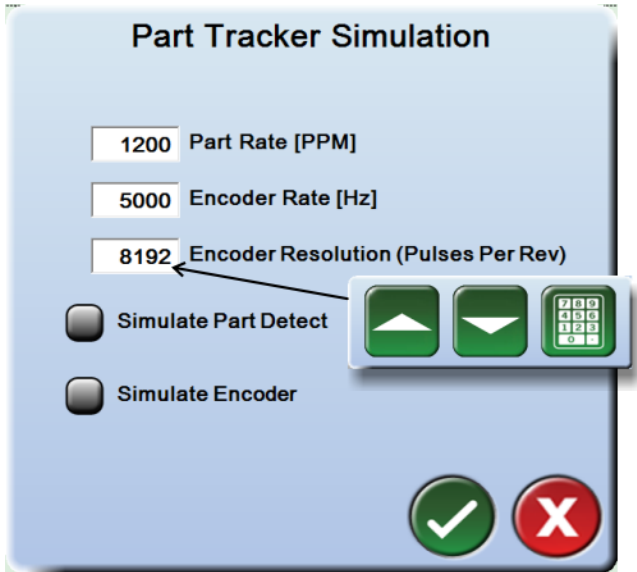

Part Rate - Enter a simulated part rate in parts per minute (PPM).

Encoder Rate and Resolution - Enter the simulated encoder properties.

Note: the system cannot run in both PDX mode and Part Tracker Simulation mode at the same time. If one mode is already running and you enable the other mode, the system displays a warning that the latest setting will override the previous mode.

Offline Imaging

Acquire images when the lane is offline. To see this menu, right-click over a sensor button, then select Offline Imaging.



Triggered Mode

Single Image - a picture is taken every time the button is clicked. (it uses the part detector)

Run - pictures are taken continuously as each part triggers the part detect sensor.

Immediate Mode

Single Image - a picture is taken every time the button is clicked. (it does not use the part detector)

Run - the camera takes continuous pictures, using the "Image Update Interval." You see whatever is under the camera.

Image Analysis

Measure the gray shade value, or distance between, pixels in your image. This is available offline only.

Note: to quickly measure a gray shade in an image, use the Image Magnifier instead (click or right-click an image).

To get to Image Analysis: Make sure the lane is offline. Right-click a sensor button | Image | Image Analysis.

Image Analysis for Sensor 'Body'

Marker Position: 0 = 104; 1 = 263; Distance = 159

Marker Value Difference: (D - C) = 5

Marker Values: 0 = 163; 1 = 158

Measured Length: 1.2466 mm

Calibration Units: millimeters [mm]

Calibration Scale: 0.8022 millimeters / pixel, 1.2466 pixels / mm

1 move

2 get more images

Measure area

a - move area

b - resize area

Calibrating the Image Pixel Scale

Using Image Analysis

Image Analysis can be used to enter your actual measured values of your part and compute the units of measure per pixel. This is called Pixel Scale. This calibration can be used for any inspection on that sensor.

To compute the pixel scale:

1. Using a known good part, measure the length or diameter of an area on your part.
2. Enter that value into the Measured box.

3. Place a line or circle on the part image in Image Analysis over the same location used to measure your part. Place the markers of the line, or a circle at the edges where you want the system to measure your part.
4. Click the Compute Scale button. The system computes the pixel scale and displays the values.
5. To save the scale to the Sensor file, click the Save Scale button. The pixel scale is saved with the sensor and can be used for any inspection on that sensor.

Using an inspection

Pixel scale can be calibrated for an individual inspection or sensor. When Save Calibration is used in these inspections, you can use the calibrated information in other inspections for that sensor. The inspections that perform pixel scale calibration are:

- Measurement
- Fill Height
- Fill Height - Segmented
- Neckring Registration
- Distance

Select Measurement Unit (Review Camera Calibration)

Select a measurement unit. If you switch between inches and millimeters, the pixel scale is automatically converted. Calibration to pixel scale is performed in Image Analysis or some inspections such as Measurement or Fill Height. Calibration is used to compute measurements on a part.

The unit you select in this menu is displayed in the Inspection menus: "p in a circle" for pixels, mm for millimeters, " for inches, or blank for custom units.

To get to this menu, right-click over a Sensor button | Camera | Review Camera Calibration.

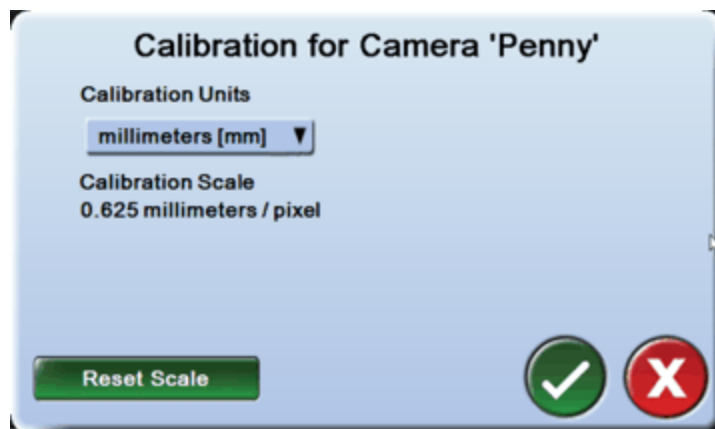

Notes:

- If you switch from mm to inches or the opposite, the scale is converted for you. However, if you switch to custom or pixels between mm and inches, then the scale is not adjusted for you.
- If you switch to pixels, the scale is set to 1.0. The scale will revert back to your calibrated value if you switch from pixels to another unit.
- The Reset Scale button sets the scale to 1.0 for any unit you have selected.

Lighting - access

Camera 1 J. Smith

Lane 1

Total Parts: 55271
Defects: 10228
Defect %: 18.505

H-axis: Parts V-axis: Defect %

Defect %

Part Count (x1000)

ALARM LEVEL 6.900%

Camera 1
Defects: 10228
Defect %: 18.505

Analysis Inspections

- Find Center ROI
- Find Center
- Orientation ROI

Camera Gain and Offset
Part Tracking
Offline Imaging
Image Analysis
Lighting
Basic Adjust Lighting
Advanced Adjust Lighting

To access the lighting software:

1. From Lane Overview mode, right-click on the desired sensor button.
2. Select Lighting.
3. Select Basic or Advanced lighting. For most adjustments, Basic lighting is adequate. Advanced Adjust lighting is used by Pressco engineers or for making infrequently performed specialized settings.

Basic Adjust Lighting

Basic lighting provides most of the lighting adjustments you will use. Lighting must be adjusted while the lane is offline.

To get to this screen: Right-click over a sensor button | Lighting | Basic Adjust Lighting.

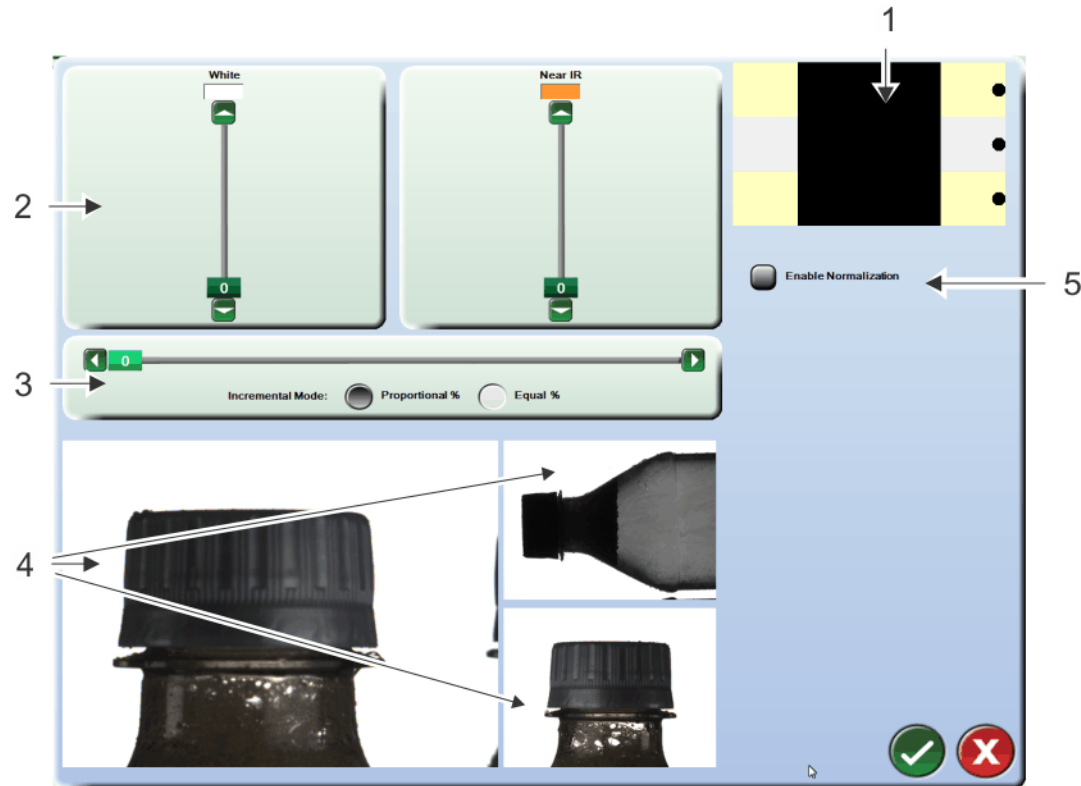

- 1) Select a zone to adjust it. You can select a single zone or multiple zones. As lighting is changed, the zone and the button next to it change color.
- 2) Separate slider bars for each color (red, green, blue, and infrared) allow individual adjustment.
- 3) Proportional % - Moving the slider bar adjusts all colors but maintains the current percentage of each color. Equal % lighting - Each color is adjusted by the same amount.
- 4) Select any image (if applicable to your system) to select the camera to adjust lighting.
- 5) Enable Normalization - (or Disable Normalization). For most applications leave normalization disabled. If you are modifying an old part program that has normalization enabled, then leave it enabled.

Advanced Adjust Lighting

This screen provides additional lighting setup. This is mostly used by Pressco engineers, or for making infrequently performed specialized settings. Lighting must be adjusted while the lane is offline.

To get to this screen: Right-click over a sensor button | Lighting | Advanced Adjust Lighting.

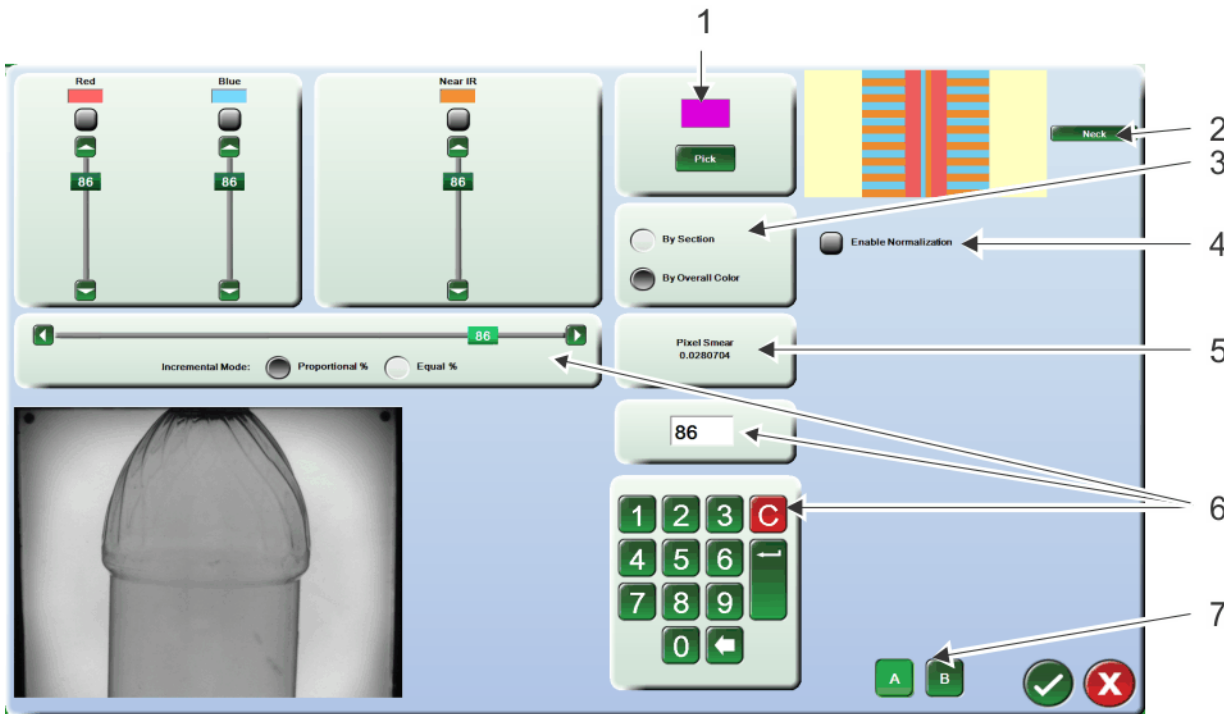

- 1) Opens a color palette and allows you to choose preselected colors.
- 2) If your inspection module has different lighting arrays, click one of the array buttons to adjust lighting by zone.
- 3) By Section - Change lighting by each section. By Color - Change lighting for multiple sections at once.
- 4) Enable Normalization - (or Disable Normalization). For most applications leave normalization disabled. If you are modifying an old part program that has normalization enabled, then leave it enabled.
- 5) Pixel Smear - The Intellispec computes the amount of pixel smear from lighting, image size, and part rate. It should be kept below one.
- 6) On-screen keypad - enter the percentage of color. This also moves the percentage slider.
- 7) A/B buttons - Set up two different lighting settings for the same part so you can compare.

Base and Neck Lighting

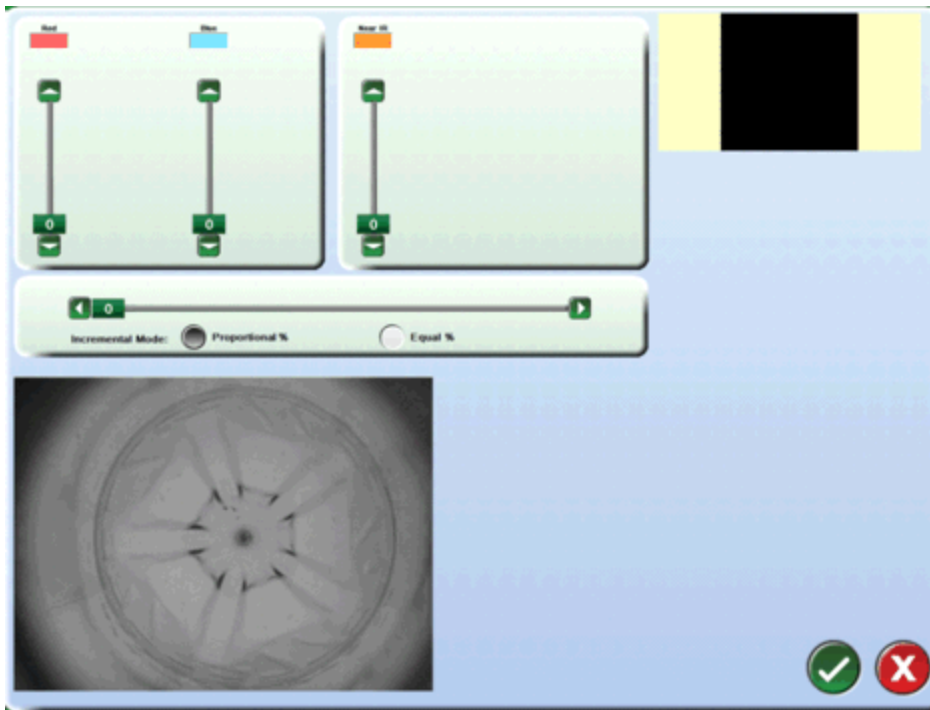

Both Base and Neck cameras use a light array with Red, Blue, and Infrared LEDs.

Red - detect off-color bottles

Blue - detect pearly

Infrared - detect defects in darker bottles (uses infrared to see through bottles)

Neck Camera - Advanced Light Adjustment

The Neck Camera light settings MUST have the Zone Delays set at 350 microseconds. Typically, this is set by a Pressco technician, but if this has not been done, the Neck Camera icon and the Neck Camera rejected images will be blank, like this example:

NO ZONE DELAYS SET:

Zone microseconds

1	0
2	0
3	0
4	0
5	0
6	0
7	0
8	0

Neck Defects: 0 Defect %: 0.000

07 24 26 07 24 27 07 24 48 07 24 52 07 25 00 07 25 00 07 25 15 07 25 23

ZONE DELAYS SET:

Zone microseconds

1	350
2	350
3	350
4	350
5	350
6	350
7	350
8	350

Neck Defects: 0 Defect %: 0.000

06 19 08 06 19 10 06 19 10 06 19 11 06 19 12 06 58 10 06 58 10 06 58 10

Advanced Lighting Software - Set Delay

This provides a strobe delay for a camera, so that the lighting for all cameras does not all occur at once. For example, in a Base and Neck inspection system, the Base and Neck part present signal occurs at the same time. A lighting delay is required so that the Base is lit separately from the Neck.

Note: this setting is normally done in the Pressco factory. You should not need to adjust it.

To get to this screen:

1. Right-click over a Sensor button to see the sensor menu | Lighting | Advanced Adjust Lighting.
2. In the upper right corner of the lighting screen, click one of the array buttons to go to the zone adjustment screen.
3. Click the Set Delays button. The Zone Delays menu is displayed.

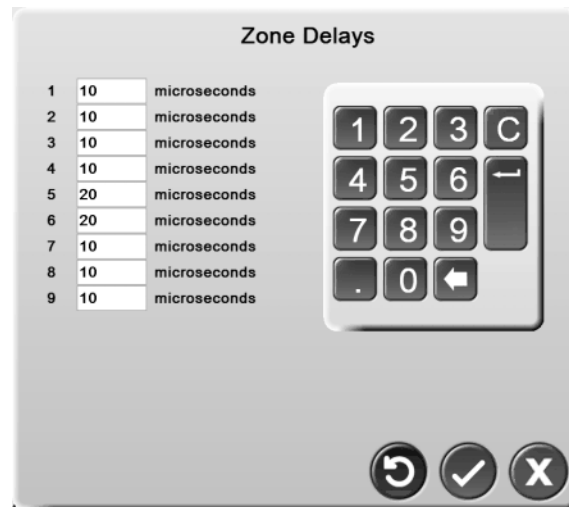

To adjust zone delay:

1. Enter the number of microseconds for each zone with the keyboard. The normal setting for the Neck camera is 350 microseconds on each zone.
2.  Click the OK button to save changes and exit the menu.

Note: this delay is separate from the Strobe Delay set in Part Present Delay Calibration.

Seal Lighting

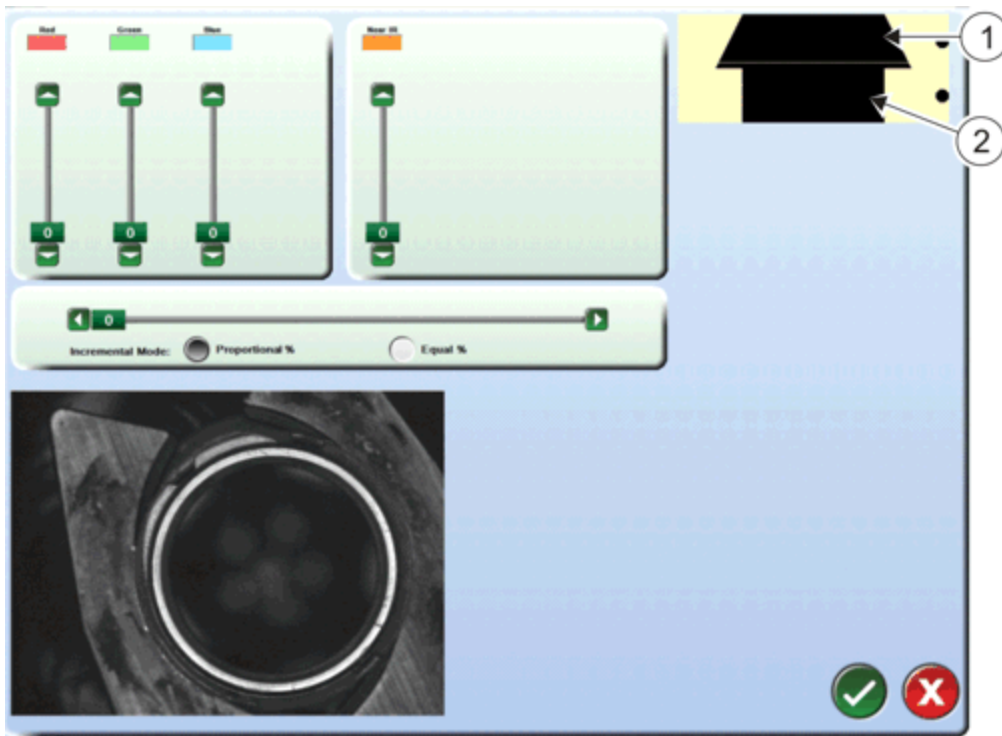

The Seal light array uses a wider 'main' light [item 1] and a narrower 'fill' light [item 2].

- You can select either the Main or Fill lights by clicking on the graphic at the top right of the screen
- Both of these lights use red, green, blue, and infrared LEDs.

Module 6 Part Tracking

In this section:

Sequence of Events During Inspection	101
Part Tracking Terminology	102
Encoder	103
Encoder/ PDX "Timing Wheel"	104
Part Tracking Using a PDX	105
Part Width Calibration	106
Part Present Delay Calibration	107
Reject Delay and Dwell Calibration	109
Reject Confirm Calibration (optional)	110
PDX Configuration	111
Part Width Calibration using PDX	114

Sequence of Events During Inspection

This illustration shows a typical inspection sequence of events. Note that your system configuration may involve more components, and may be different than pictured here.

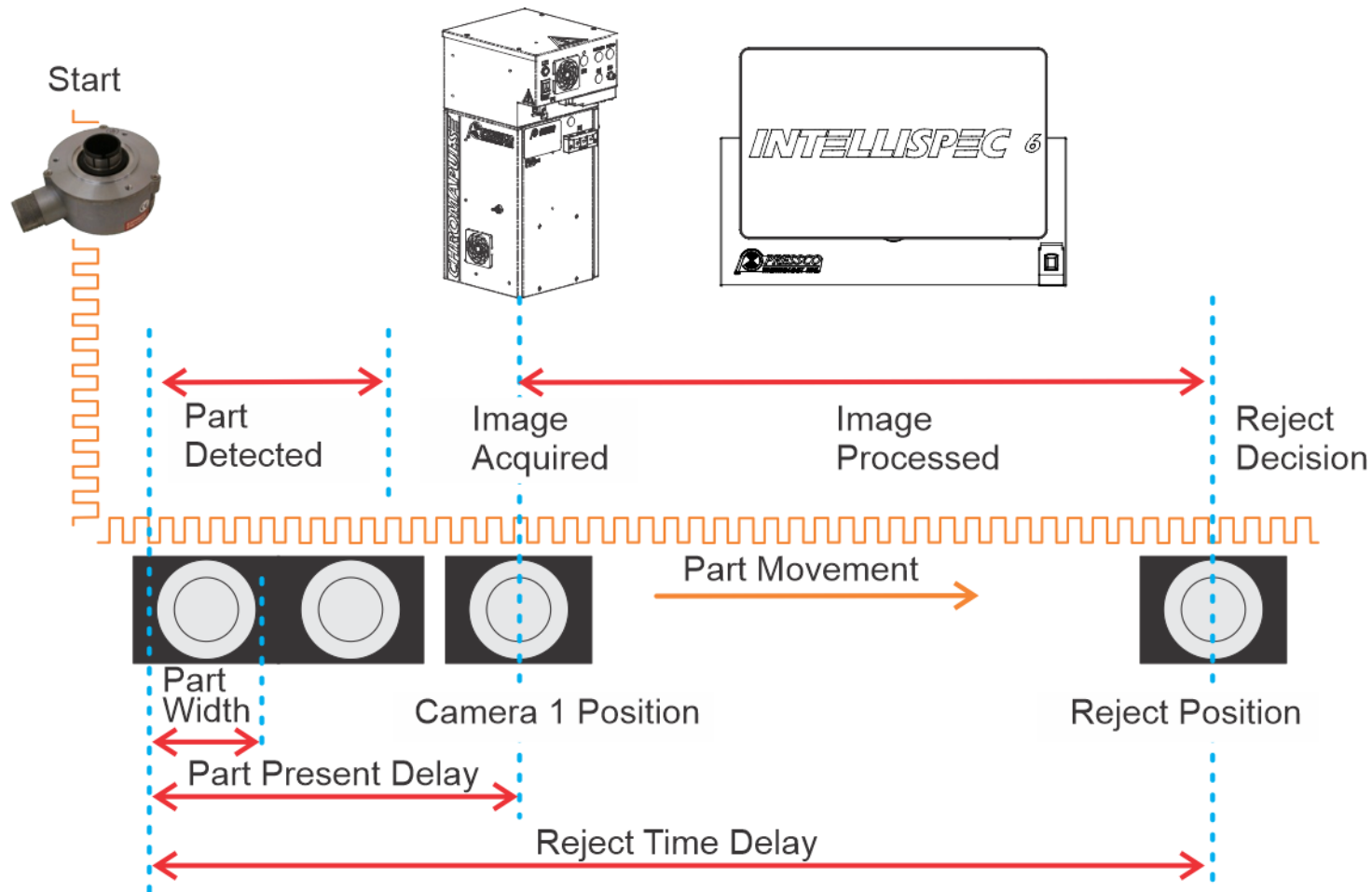

Part Tracking Terminology

Part Width - The number of encoder ticks that the part sensor "sees" the part.

Part Present Delay - The distance (in encoder ticks) from the part detect sensor to the camera centerline. If a PDX is used, this is the number of encoder ticks from the part detect pulse out of the PDX to the camera centerline.

Reject Dwell or Reject Pulse Width - The duration (in milliseconds) of the reject signal. This signal must be long enough to ensure the part is efficiently rejected, and short enough to ensure that only one part is rejected for each reject pulse.

Adaptive Reject - This feature is necessary when you have a significant change in product speed, since the rejector has a constant turn-on time. This logic allows the system to monitor the product speed and compensate the pulse being sent to the rejector.

Reject Confirm - Not commonly used. This is the distance in encoder pulses from the reject mechanism to the reject confirm sensor (if installed).

Encoder



Encoder - A device used to indicate mechanical motion with a pulse rate directly proportional to line/ conveyor speed. The system tracks part movement through encoder ticks, from the moment the part is detected until it passes the reject station.

Encoder/ PDX "Timing Wheel"

Encoder sensor counts pulses to know the position of the part



The encoder "Z" indicator is used to zero the count when the wheel has turned a full 360 degrees

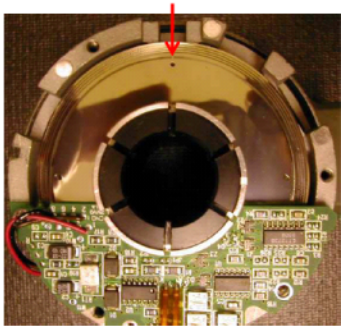

Part Tracking Using a PDX

The Part Detect Generator (PDX) is used in some applications where the Intellispec system inspects directly on a machine, rather than on a conveyor. The PDX is a circuit built into the Part Tracker board.

If a PDX is used, part tracking is done by:

- Monitoring the movement of the transfer wheel (or other machine component) with the encoder
- Feeding the signal to the software
- Programming the software with the resolution of the encoder and the number of pockets used
 - This generates a part detect pulse for every pocket
 - This part signal is used to acquire part images and generate reject pulses

An empty pocket inspection must be applied if using a PDX. The PDX tracks pockets, not parts, so the empty pocket inspection determines whether the part is in the pocket.

Advantages of using a PDX:

- No part detect sensor is used and therefore no component can be accidentally moved by a machine crash or during maintenance
- Part timing should not be affected when running different parts

Part Width Calibration

Part Width is the number of encoder ticks that the part detect sensor "sees" the part. To perform the calibration you must be running parts past the part detect sensor.

For systems using a PDX, the Part Width Calibration is not used, but values of 0 and 1 should be used respectively for Part Width and Part Present Disable Time.

Part-Width Calibration

In Use New Value

Part Width 0 (Encoder Ticks)

Part-Present Disable Time 0 (Encoder Ticks)

Start Calibration

Calibration Results (Part Width)

Parts	Avg.	σ	Min	Max
127	71.46	14.89	45	94

Simulation

To calibrate the Part Width:

1. From Sensor Overview mode, right-click a sensor button | Part Tracking | Part Width Calibration.
2. With parts running under the camera or sensor, select Start Calibration. As each part goes by its width is displayed in Part Width field.
3. After a sufficient number of parts have gone by (we recommend about 10 parts), select "Stop Calibration" (same button as Start Calibration). This will display the calibration results in the lower part of the screen.
4. Examine the results; look for the minimum and maximum values to be within approximately 10 encoder ticks of each other. If the results are acceptable select OK to save the data. If the results are skewed, recalibrate the part width. To exit without saving the changes, select the exit button.
5. The system will prompt you to confirm your changes. If the results are acceptable select OK to save the data. If the results are skewed, select the cancel button and recalibrate.

Confirm changes

Do you want to apply the following changes to the system?

Part width changes from 0 to 72 encoder ticks.
Part present disable time changes from 0 to 3 encoder ticks.

Part Present Delay Calibration

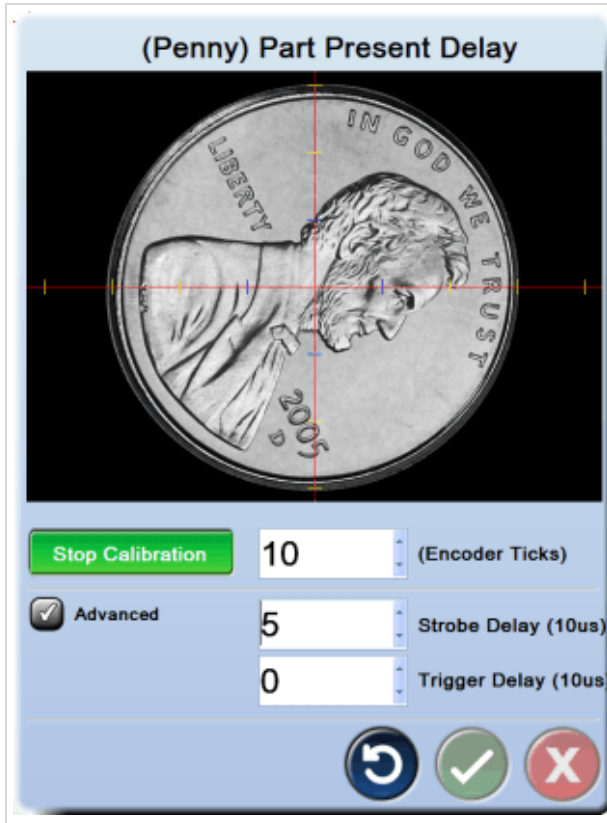

To calibrate the Part Present Delay:

1. From Sensor Overview mode, right-click a sensor button | Part Tracking | Part Present Delay Calibration.
2. Select the Start Calibration button.
3. Place a part onto the conveyor or into the part stream. The part will trigger the part detect sensor, then the system will count the number of encoder ticks and take a picture.
4. Manually adjust the part present delay (encoder ticks) value until the image is centered every time a part is run through the system.
5. When completed, select the Stop Calibration button. The Part Present Delay calibration value is saved and stored in a Lane configuration file.
6. Select the OK button to save changes and exit.

Part Present Delay - Advanced settings BNS

Note: Advanced settings are normally set at the Pressco factory. You should not need to adjust them. Normal settings are listed below.

Camera	Strobe Delay	Trigger Delay	Part Present Delay
Base	5	0	same as Neck
Neck	5	30	same as Base

Also check "Advanced Lighting Software - Set Delay" - set delay to make sure that the Neck lighting delays are set correctly.

Reject Delay and Dwell Calibration

Calibrating Reject Delay and Dwell takes time and patience. In preparation, gather several different preforms if available, and/or use a marker to create 'defects' on preforms. Use as many preforms as it takes to complete proper calibration.

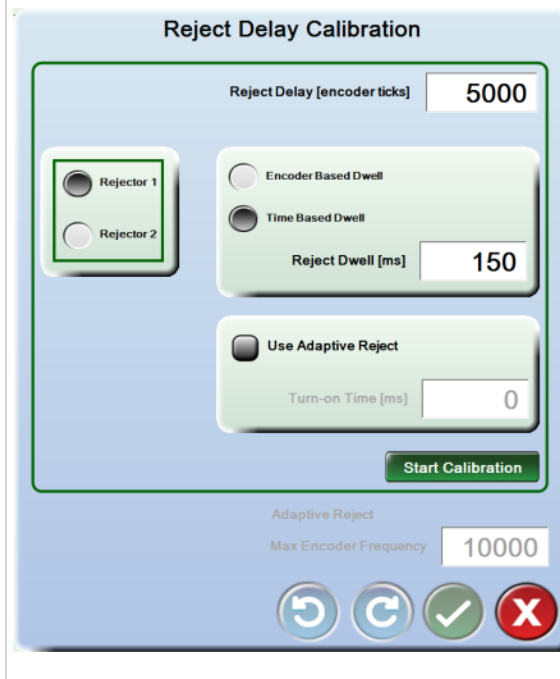

To calibrate the Reject Delay:

1. From Sensor Overview mode, right-click a sensor button | Rejecting | Reject Delay Calibration.
2. Select the Start Calibration button.
3. Place a part on the running conveyor or into the part stream. After the number of encoder ticks shown in the Reject Delay box, the rejector will be activated.
4. Make sure the correct part was rejected.
5. Continue to insert parts into the part stream.
6. Manually adjust the reject delay (encoder ticks) until the correct part is rejected every time.
7. Adjust Reject Dwell so that it is long enough to completely reject the part, and short enough that only one part is rejected for each reject pulse.
8. When completed, select the Stop Calibration button. The Reject values are saved and stored in a Lane configuration file.
9.  Select the OK button to save changes and exit.

Reject Confirm Calibration (optional)

Reject Confirm Calibration

Reject Confirm Delay [ms] 56

Start Calibration

Rejector 1 Enable Confirm Time Based

Rejector 2 Enable Confirm Time Based

Gate Size 1 10 milliseconds

Sensor Noise Filter 1 0 milliseconds

Gate Size 2 10 milliseconds

Sensor Noise Filter 2 0 milliseconds

Jam Detection Timeout 42 ms

To calibrate Reject Confirm:

1. From Sensor Overview mode, right-click a sensor button | Rejecting | Reject Confirm Calibration.
2. Check Enable Confirm.
3. If using time-based Reject Confirm, then also check the Time-Based box, and set Gate Size, Sensor Filter and Jam Detection Timeout.
4. Select the Start Calibration button.
5. Run a part through the system. Tip: for best results, run about 10 parts through the system.
6. When completed, select the Stop Calibration button. The system will compute Reject Confirm Delay. [Reject Confirm Delay = (number of pulses from Part Detect to Reject Confirm Sensor) minus Reject Delay]
7.  Select the OK button to save changes and exit.

The following parameters are used only with Time-Based Reject Confirm:

Gate Size - The time interval (in milliseconds) that the system looks for the product to pass by the reject confirm sensor. The valid range is 1 to 63 milliseconds.

Sensor Noise Filter - The shortest pulse width (in milliseconds) that the reject confirm sensor will pass. This is used to filter out glitches or noise. This is usually set much smaller than part width, but larger than glitches or noise. The valid range is 0 to 4 milliseconds.

Jam Detection Timeout - Specifies how long the sensor is blocked before the Jam at Reject Confirm alarm is triggered. This alarm must be enabled through Lane Alarm Configuration. The valid range is 1 to 32000 milliseconds.

PDX Configuration

The Part Detect Generator (PDX) is used in some applications where the Intellispec system inspects directly on a machine, rather than on a conveyor. The PDX is a circuit built into the Part Tracker board.

Note: the system cannot run in both PDX mode and Part Tracker Simulation mode at the same time. If one mode is already running and you enable the other mode, the system displays a warning that the latest setting will override the previous mode.

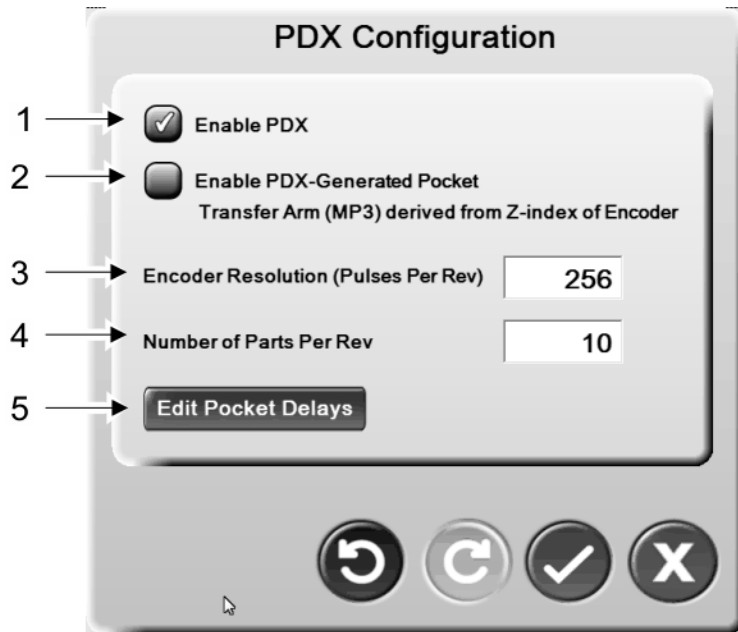

 To get to this screen: From Lane or Sensor Overview mode, select Tools | Hardware Setup | PDX Configuration.

To configure the PDX:

1. Select the Enable PDX check box.
2. Enter the encoder resolution used on your system (example, 8192 pulses per revolution).
3. If your system is NOT using a pocket disk to generate the index signal, check the Enable PDX-Generated Pocket box.
4. Select the OK button to accept changes and exit.

1) **Enable PDX** - Enables the PDX circuit.

2) **Enable PDX-Generated Pocket** - On Most systems - If your system is not using a pocket disk, and you need the Z-index signal of the encoder, check this box. This eliminates the need for a pocket disk. The index signal is handled on the Part Tracker board. Or, if your system is using a physical pocket disk with an index pin, leave this box un-checked.

3) **Encoder Resolution (Pulses Per Rev)** - Enter the resolution of the encoder installed on your machine.

4) **Number of Parts Per Revolution** - Enter the number of machine parts or pockets (example, number of Transfer Arms) where the encoder is attached.

5) Edit Pocket Delays

This feature only needs to be used if machine parts become unevenly spaced. If your system has rigid machine parts and consistent spacing part to part, then no further action is needed.

For this explanation, Encoder Resolution [3] = 256. Number of Parts Per Rev [4] = 10.

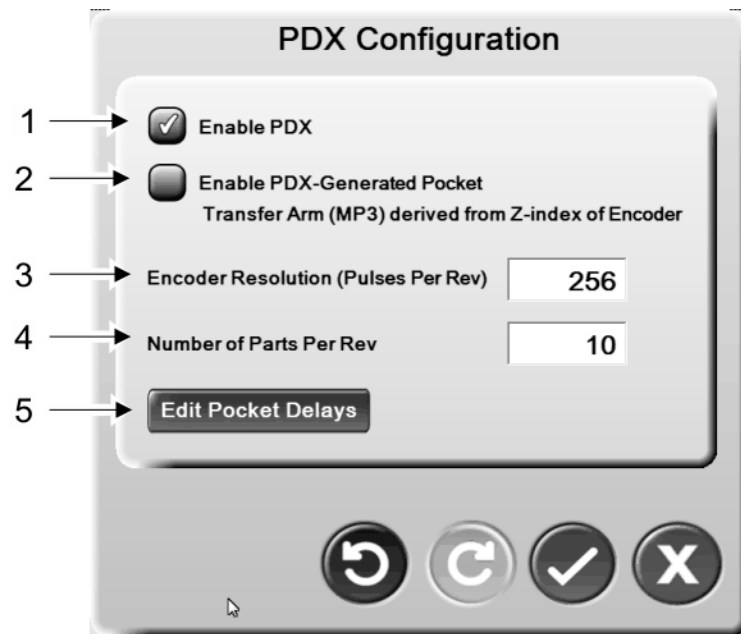

When you click the Edit Pocket Delays button, you can manually change the delays, as shown below.

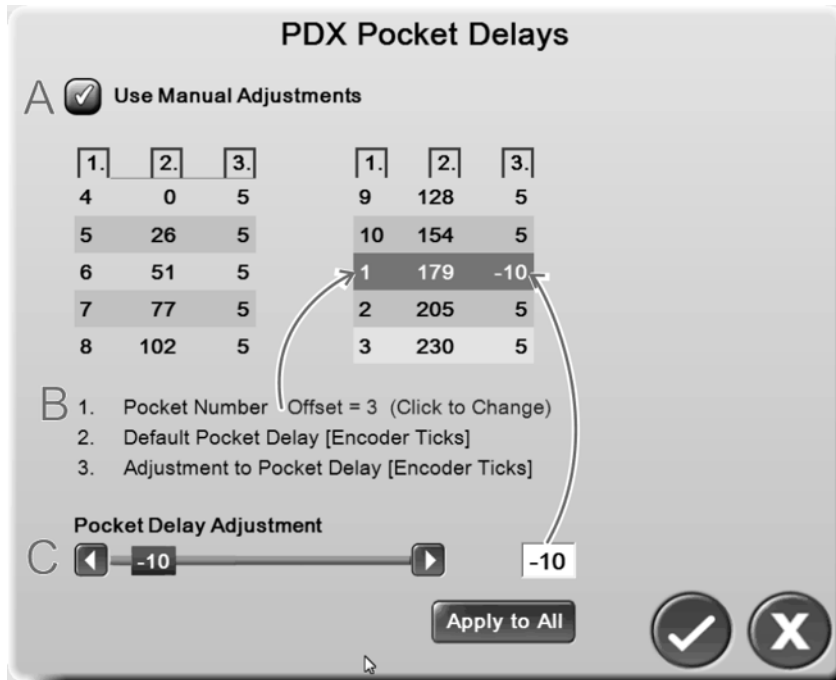

A) checked = enabled

B) Pocket Number [Column 1] - If you have a pocket (physically) marked as pocket #1, but the index pulse is 3 pockets away, you can use 3 as an offset (as shown in the above example). If the index pulse is located at pocket #1, then no offset is necessary.

Default Pocket Delay [Column 2]- This is computed for you. The system divides Encoder Resolution [3] by the Number of Part Per Rev (pockets) [4], and computes the delay between each pocket.

C) Pocket Delay Adjustment [Column 3] - You can change the delay for one pocket, or Apply to All. If just one machine part has shifted, then you may only need to change the delay for one pocket.

You may notice that sometimes you can enter a negative number, and sometimes not, or a value for the last pocket is limited more than others. Pocket delays are sent as a list of values to the part tracker. The system computes valid values for the part tracker rules, which include: non-negative values, subsequent delays are larger than the previous delays, and the last delay must be fewer ticks than the encoder resolution.

Part Width Calibration using PDX

Note: For systems using a PDX, the Part Width Calibration is not used, but values of 0 and 1 should be used respectively for Part Width and Part Present Disable Time.

Module 7 System Maintenance and Troubleshooting

In this section:

Maintenance Cautions	116
Maintenance Frequency	117
Clean the Control Cabinet Filters	118
Clean the Cluster Box Filters	119
Cleaning the Beam Splitter Seal Surface module	120
Cleaning the Beam Splitter PSE Module	121
Cleaning the Part Detector and Reflector	122

Maintenance Cautions

When carrying out maintenance or repair work:



Disconnect master switch. For switch locations, refer to the Power Up and Power Down section.



Before starting the machine, ensure that no person is close to the machine.



If maintenance or repair requires the disconnection or removal of safety or protection systems, this operation must be supervised by authorized personnel who must ensure the prevention of personal injury or damage to the machine. All machine movements must be performed with limited speed and limited movements.



Maintenance or repair work on electrical components must be carried out exclusively by authorized, trained personnel. When running tests with power connected, you must strictly comply with the rules provided.



Personnel working on higher parts of a machine must wear a harness and hook it on to the structure and must always move with extreme caution.



Never perform lubrication or maintenance procedures on mechanical parts with the machine running.

LED Caution:



CAUTION - Possible hazardous optical radiation from LEDs. Do not stare at lamps.

Maintenance Frequency

Empty Bottle Inspection Maintenance

Maintenance Frequency

Observe proper rejection	Verify that defective parts are being rejected, by inserting a known defective part through inspection	Daily
Observe Proper inspection	Verify that no stray parts are stuck in or near the inspection module or reject station	Daily
Observe Proper inspection	Verify that no buildup of dirt or contaminants has occurred on inspection module. Clean if necessary.	Daily
Observe Proper inspection	Verify that each camera's image is properly centered, focused, and properly lit. Adjust if necessary.	Daily
Glass surfaces	Clean with soft, clean, oil-free cloth dampened with glass cleaning solution.	Daily - as needed
Plastic surfaces	Clean with soft, clean, oil-free cloth dampened with mild soap and water solution.	Daily - as needed
Control Cabinet filter	"Clean the Control Cabinet Filters" on the next page	
Cluster Box filters (if applicable)	"Clean the Cluster Box Filters" on page 119	
Beam Splitter Seal Surface and PSE modules	Clean with soft, clean, oil-free cloth dampened with lens cleaning solution. "Cleaning the Beam Splitter Seal Surface module" on page 120 "Cleaning the Beam Splitter PSE Module" on page 121	Monthly
Support Package	Create a snapshot of your Intellispec settings	Monthly
Acronis Backup	Create a full System Backup.	Yearly

Clean the Control Cabinet Filters

The filter should be cleaned once a month for best results. The filter is located on the side of the cabinet. Replace with a new filter when necessary.

Note: You may need to clean the filters weekly depending on plant conditions

What you need:

Recommended: "RP Super Filter Coat Adhesive." Find this on the Internet or in a hardware store near you.

To clean the filter:

1. Pull the ring on the bottom of the filter cover, and pull the filter down to remove it. (see photo below)
2. Remove the filter and clean it. DO NOT use caustic solutions.
 - If the filter contains dry dust and dirt, flush the filter with warm water from the exhaust side to the intake side
 - If the filter contains oily dust and dirt, clean it in soapy water, then rinse in clear water
3. Dry the filter completely [placing it with a corner down will assure complete drainage].
4. Recoat the filter with "RP Super Filter Coat Adhesive." Spray both sides for best results.
5. Place the filter back inside the filter cover.

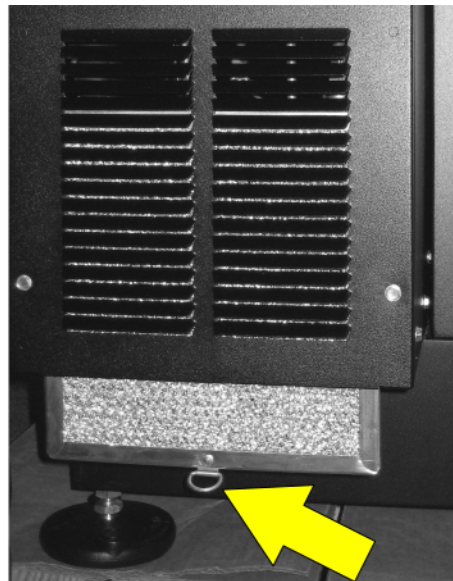
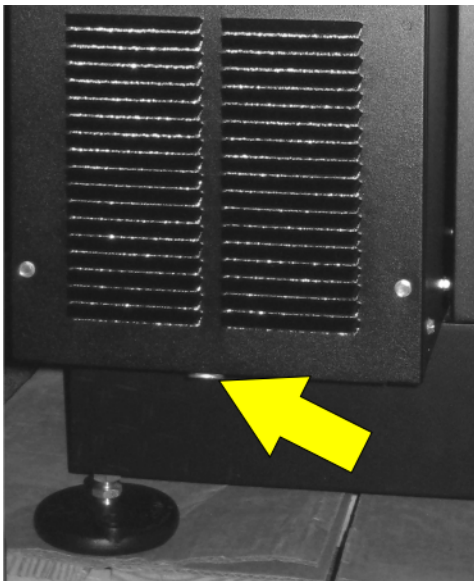

Clean the Cluster Box Filters

If you do not have replacement filters, clean them once per month. Remove the covers to access the filters.

- If the filter contains only dry dust and dirt, rinse it in plain water
- If it contains oily dust and dirt, clean it in soapy water
- Dry the filter completely before reinstalling it

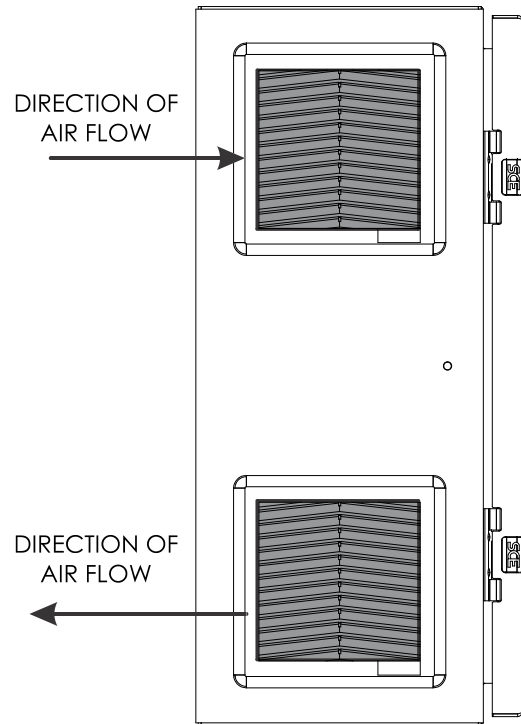

Cleaning the Beam Splitter Seal Surface module

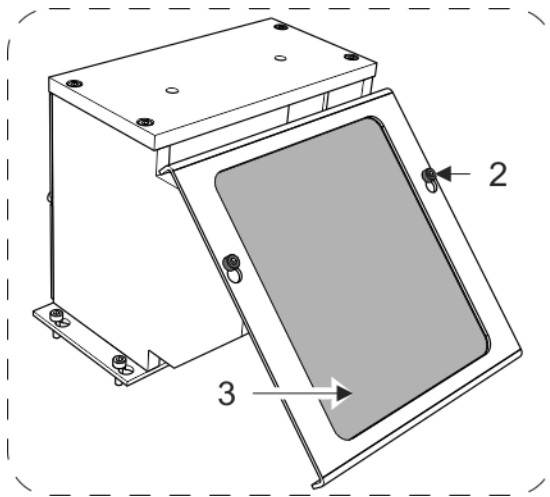

2	Screws
3	Beam Splitter

To clean the beam splitter:

1. Raise the camera if necessary. Be sure to note the camera position before moving it.
2. Loosen the two screws [item 2] and carefully remove the beam splitter.
3. Clean the beam splitter [item 3]:
 - Blow off dust from beam splitter with canned, compressed air.
 - Clean the glass on the beam splitter using lens tissue and lens cleaner.
4. Replace the beam splitter with glass to the inside. Tighten the screws.

Cleaning the Beam Splitter PSE Module

You must remove the Beam Splitter to access the bottom side for cleaning. The beam splitter is used in preform sidewall endcap (PSE) modules.

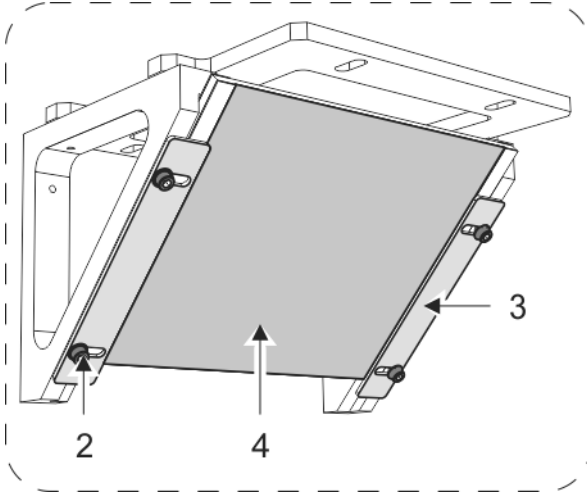

2	Screws
3	Retaining plates
4	Beam Splitter

To clean beam splitter:

1. Raise the camera if necessary. Be sure to note the camera position before moving it.
2. Loosen the four screws [item 2].
3. Slide the retaining plates [item 3] to the sides and carefully remove the beam splitter.
4. Clean the beam splitter [item 4]. Blow off dust from beam splitter with canned, compressed air.
 - Clean the glass on the beam splitter using lens cleaner and lens tissue.
 - Replace the beam splitter with the reflective side to the outside.
5. Slide the retaining plates back in place and tighten the screws.

Cleaning the Part Detector and Reflector

The part detect sensor and reflector surfaces of the part detector must remain clean to properly detect parts. Clean these surfaces regularly to prevent dirt and oil build-up.

Clean the part detector surfaces with a soft, clean, lint-free cloth dampened with a mild soap and water solution. Do not use a glass cleaning solution or strong solvent on the plastic surfaces as they might be damaged.

The frequency of cleaning will depend on plant and process conditions.

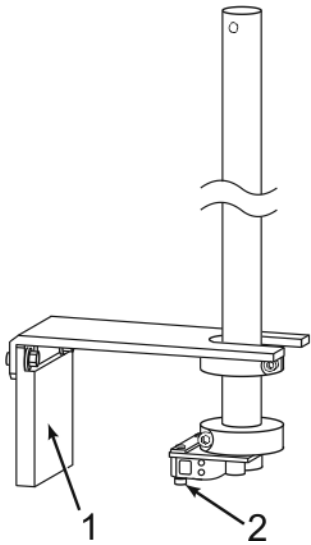

- 1) Part detect reflector
- 2) Part detect sensor

Digital Camera LED Status



STATUS LED

- Solid IP Address Assigned
- Slow Waiting for an IP Address
- Fast Ethernet Cable Disconnected
- Solid Application Linked to the Camera
- Slow Trigger Acquisition in Progress
- Fast Acquisition in Progress
- Slow Camera Initialization Problem
- Fast Camera Overheating

LED Status	Definition	
LED OFF	No power / No trigger pulse	
GREEN	Steady*	Application connected
	Slow Flashing	Triggered acquisition in progress
	Fast Flashing	Free running acquisition in progress
BLUE	Steady	IP assigned but no application connected
	Slow Flashing	Waiting for an IP Address
	Fast Flashing	Ethernet cable disconnected
RED	Steady	Camera not initialized
	Slow Flashing	Camera initialization problem
	Fast Flashing	Camera is too HOT

Link LED

Orange	1 Gb
Green	100Mb

*NOTE: Should be Orange when connected to an IntelliSpec

Traffic LED

Yellow	Traffic
--------	---------

Normal Camera Connection LED Progression

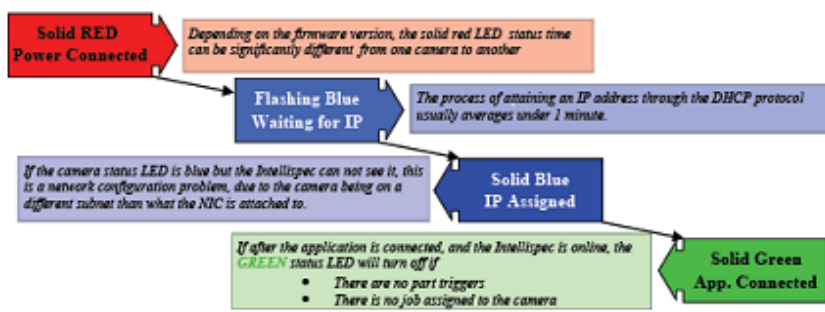

Solid RED Power Connected → **Flashing Blue Waiting for IP** → **Solid Blue IP Assigned** → **Solid Green App. Connected**

Depending on the firmware version, the solid red LED status time can be significantly different from one camera to another

The process of attaining an IP address through the DHCP protocol usually averages under 1 minute.

If the camera status LED is blue but the IntelliSpec can not see it, this is a network configuration problem, due to the camera being on a different subnet than what the NIC is attached to.

If after the application is connected, and the IntelliSpec is online, the GREEN status LED will turn off if

- There are no part triggers
- There is no job assigned to the camera

Normal On-Line Camera LED Status



Status LED Flashing Green when acquiring images

Link LED Solid Orange

Traffic LED Flashing Yellow

**NOTE: Depending on amount of traffic, the LED can be flashing so quickly it may appear to be solid yellow*

**NOTE: If a camera is connected while the application is running the status LED may turn green but it might not acquire images. To avoid this, always power down the IntelliSpec when connecting a camera.*

Help - Remote Support

Remote Support allows remote access to the Intellispec software. iTivity software is used by Pressco to provide remote system support if a Maintenance Agreement is purchased for that Intellispec system.

Note: your plant may use TeamViewer for remote support instead of iTivity. Contact Pressco's Technical Support to connect.

You will need:

- A functioning Intellispec (systems without power, or systems that are not capable of running Intellispec software, cannot be remotely accessed)
- An internet connection to your Intellispec. This can be established through your network, and is usually set up during installation. You may use DSL, Cable, Mobile Broadband, or plant network connections to connect to the internet. Contact your network administrator for help.

To use Remote Support:

1. Notify a Technical Support representative that you require remote support. You will need to identify yourself, your location, and the Intellispec to which he should connect.
2.  In the Intellispec software, Select Help | Remote Support.

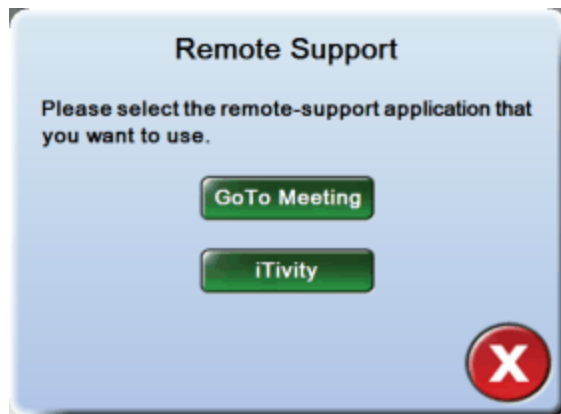

3. Select the iTivity button. If your system has a valid internet connection, the iTivity agent will attach to the server at Pressco. A connection status screen will appear indicating that the session has been established, as shown below. Intellispec systems are identified by computer name, which, in most cases, is the serial number.

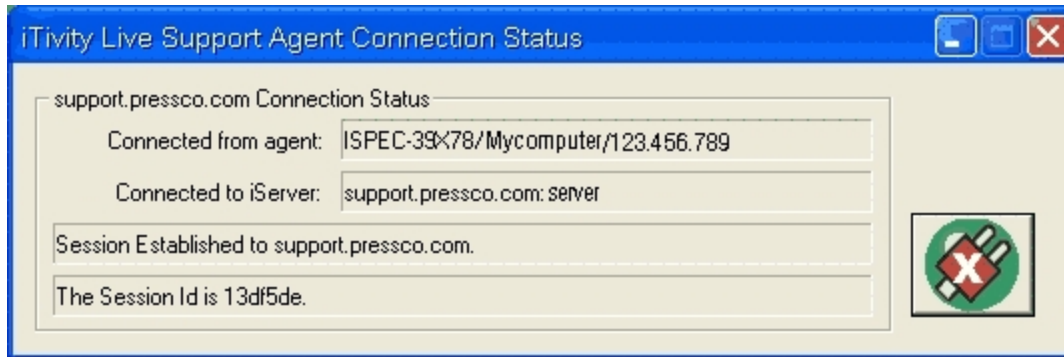

4. When the Pressco Tech Support representative is connected, you will be asked to give him control of your Intellispec system. Check Allow remote user MOUSE and KEYBOARD control and select Accept. The Tech Support representative will now perform the necessary troubleshooting of your system.

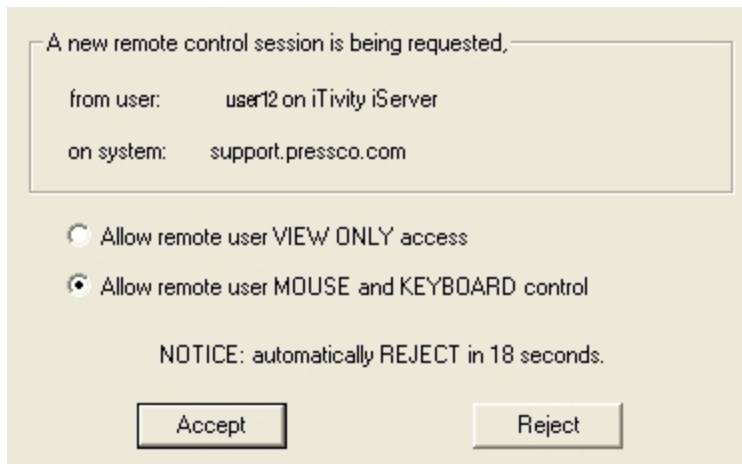

5. When the Tech Support representative is finished, he will disconnect your Intellispec from the remote session.

If you need to disconnect your Intellispec from the remote session yourself, follow the steps below.

To disconnect from remote support:

1. Select the X in the upper right corner of the 'iTivity Live Support Agent Connection Status' box.
2. When the system asks "Do you really wish to exit the iTivity Live Support Agent?" select OK. The system will be disconnected.



Note: if you select the button, the session will be disconnected, but this does not close the remote support program.

If the session is disconnected and you want to allow Tech Support to be able to access your system again, select the button.



support.pressco.com Connection Status



Agent disconnected:	ISPEC-39X78/Mycomputer/123.456.789
Disconnected from iServer:	support.pressco.com: server
Not Connected.	
The Session Id is 1ab1b77.	





Exiting the Intellispec Software

You must have proper user permissions to exit the software. This prevents unauthorized system shutdowns. Contact your system administrator if you need user permissions.

To exit Intellispec software:

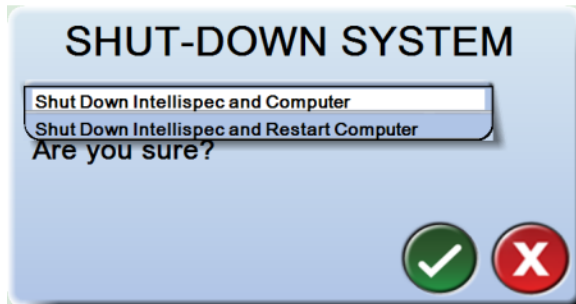
1. Log in.
2.   Select Home | Tools | Exit System.
3. Select an option.



4.  Select the OK button. The Intellispec software and/or computer shuts down (and restarts if applicable).

Discovery Software - What is Discovery?

Discovery is software installed on the Intellispec hard drive that automatically looks for and identifies certain components installed on each lane. The software identifies sensors, cameras, lighting drivers, part trackers, and if used, Intellimass drivers that are attached to the system. Each one of these devices communicates with the Intellispec software via Cat -6 cabling and is assigned a unique MAC address.

Note: You should rarely need to use this software. However, if a new component (for example, camera) is installed on the system the software would be used to configure the new camera.

Additionally, during system startup, if a previously configured component fails to communicate with the Intellispec software, the discovery software screen will automatically appear on the user interface, alerting you to the problem.

Discovery software screen



1) The Discovery menu toolbar allows you to perform additional actions.

2) The tree shows the system configuration. Red indicates unassigned hardware devices. Orange indicates missing hardware devices.

3) Select one of the buttons to perform specific actions, such as add or edit lanes or sensors.

Discovery Menu Toolbar



Tools Menu

- Rediscover New Hardware - when this command is initiated this software will perform another search of all hardware communicating with the Intellispec and displayed in the tree on the left side of the screen.
- Add Simulated Devices for Testing - this is software used by Pressco engineers to assign devices on an Intellitrainer.*
- Inspection Module Preset Editor - this is software used by Pressco engineers to assign new components as they become available.

 Wizard Menu - the same choices as those listed in the green buttons in the center of the screen.

 Language Menu - displays language choices that can be displayed.

 Help - provides software and systems for users.

*Intellitrainer = portable Intellispec training computer.

Module 8 Part Programming - General Information

In this section:

Part Changeover	133
Manage Part Programs	135
Create or Copy a Part Program	137
Inspection Overview	138
Inspection Tree Configuration	142

Part Changeover

When changing parts to inspect, you only need to change the part program (if you have a part program already set up for the newly inspected part type).

This will load the proper inspections, lighting, and guide rail settings, if applicable (as long as these were previously set).

Note: Some menu items are available to advanced users only

What you need:

User permission to Switch Part Program

To change parts:

1. Log in.
2. Click the part drop-down menu.

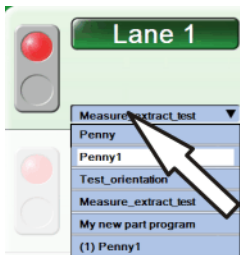

3. Click the name of the new part to inspect. The new part program is loaded on the Intellispec.
4. Click the statistics panel and select Clear Lane Statistics, to begin counting statistics for the new production run.

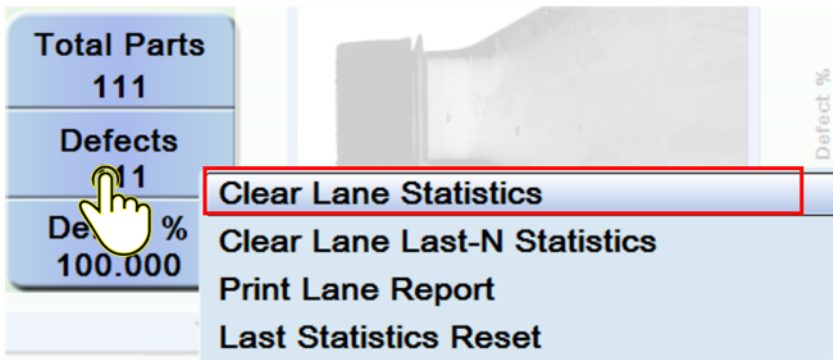

5. Put the lane online to begin inspecting new parts.

Lane-specific information is contained in each Part Program. Everything you set up have previously set up is stored: camera information, lighting information, calibration information, and inspections.

Manage Part Programs

Create new part programs or delete, edit, rename, import or export existing part programs for all the different products inspected with the system.

To load a part program, see [Part Changeover](#)

To get to this screen:

-  From Lane or Sensor Overview mode, select Tools | Lane Setup | Manage Part Programs. Or:
- Right-click the Part Program drop-down.

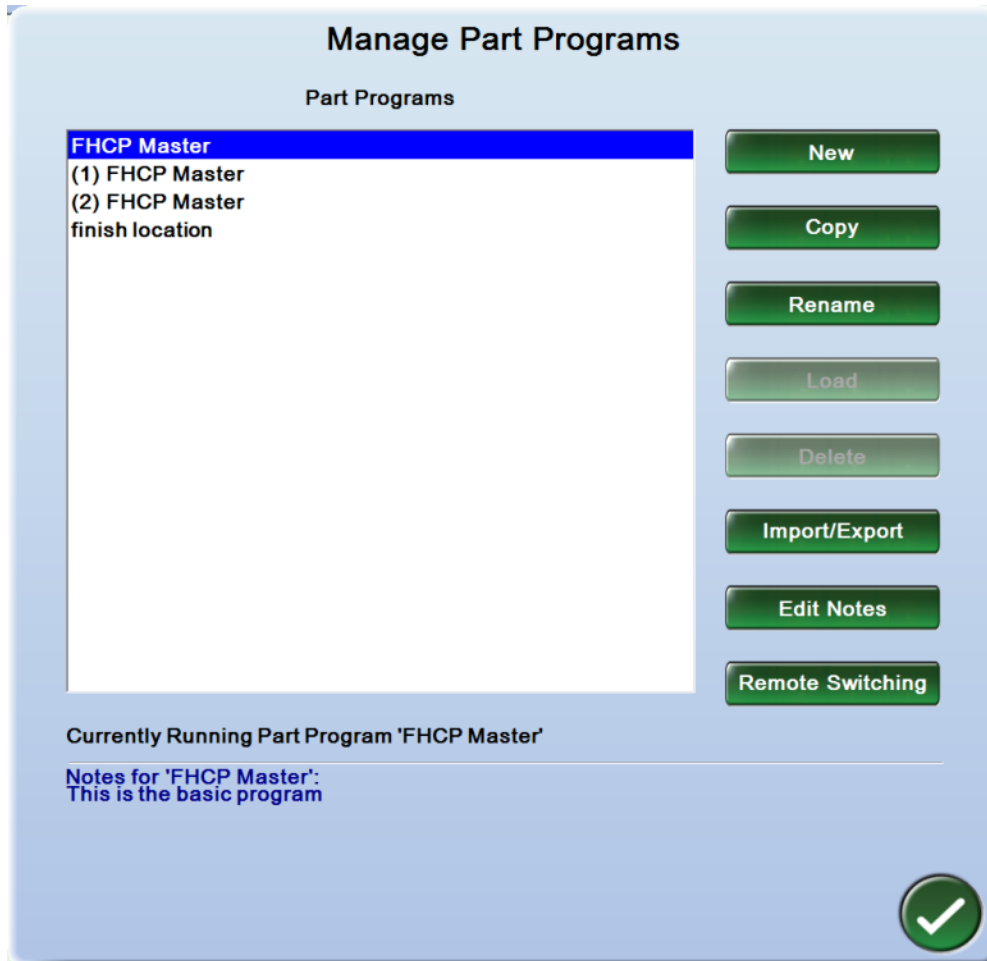

Edit Notes - Add setup and program information about the part. This is helpful if you need to modify the part program later. These notes are displayed at the bottom of the Manage Part Programs screen when you select or change a part program.

Create or Copy a Part Program

You will need:

System permissions to create part programs

To create a Part Program:

1. Go to a Lane Overview or Sensor Overview screen.
2. Right-click over the part program drop-down menu. Choose from the available options.



Right-click

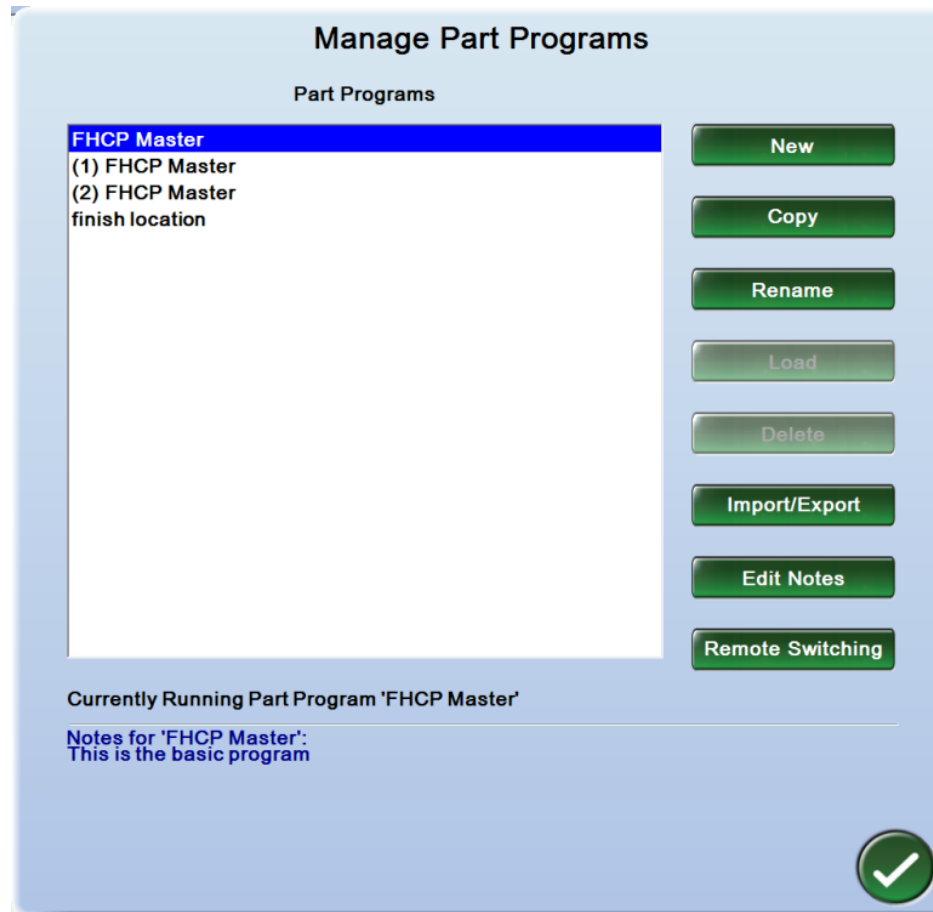

Inspection Terminology

Analysis - Analyzes the pixel shade information within a region and compares it to reference values. The inspection passes or fails based on these comparisons. There are also several analyses that make measurements. You may have many analyses for each inspection region.

Dimension - The dimension inspection type connects the results of two other inspections to do the analysis. For example, a distance inspection can connect two registrations to measure the distance between centers of two features.

Enhancements - Enhancements are used to alter images for better defect detection, or for making certain features stand out.

Inspection Module - The housing, camera, cables, and associated electronics that are installed on or over the production line to acquire an image of your product. Sometimes referred to as a tunnel. The inspection module can have a different sensor than a camera to make measurements of your product (example: Intellimass sensor).

Lane - A lane usually refers to one production line, and can contain multiple sensors.

Orientation - An orientation compensates for part rotation by finding a grayscale pattern. An analysis which must rotate with the part must follow an orientation.

Part Program - The list of regions, analyses, registrations, etc. programmed specifically for your part to detect defects or make measurements.

Part Tracking - refers to the monitoring of parts from the part detect sensor to reject station. This ensures that the correct parts are rejected at the correct time, and that good parts remain in the part stream.

Region - The Region indicates where on the part the analyses will take place. You may have as many inspections as you like in one region.

Registration - A registration compensates for part movement by finding the reference point on the part. All analyses follow a registration.

Reject - A part that failed one or more inspections from any sensor. The part can be physically rejected, or simply counted in the statistics.

Retro-Spec - The graphical interface that allows you to make quick changes to a part program. It also allows you to experiment with different parameter settings to see how changes affect the most recent inspection population, without rejecting parts.

Sensor - A camera, Intellimass, or other sensor that acquires images, measurements, or other data from your product.

Icon or Symbol Options (Sensor Menu)



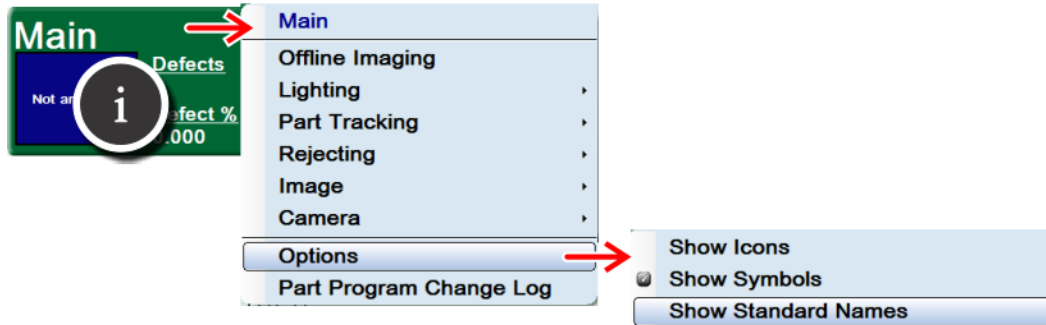

Icons or symbols indicate the General Type of inspection for each item. Checked = enabled

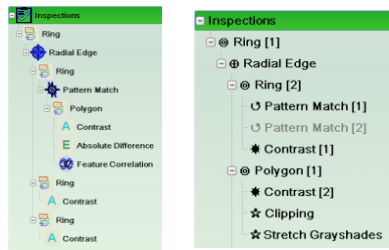

Show Icons Show Symbols



Icon	Symbol	General Inspection Type
		Region - location of inspection
		Registration - to find part center or point of reference
		Analysis - inspection
		Correlation - inspection to correlate a part to the machine part where it was made
		Orientation - to place an inspection on the same location on each part, regardless of part rotation

Icon	Symbol	General Inspection Type
		Enhancement - to add image processing to make defects or part features stand out better
		Intellispec Mass inspection

Show Standard Names

Displays the default Intellispec inspection names. You may use other inspection names that make sense for your part (example: upper wall).

Showing Standard Names is useful to Pressco engineers or to someone troubleshooting your machine, so that they quickly know the exact inspection type.

The Standard Names are used in the Pressco manuals.

Inspection Tree Relationships

The inspection tree shows the relationship of each inspection. Indented objects are dependent on the object above it. Some items in the menu may be turned off. The ability to access some items depends on your user access.



See also ["Icon or Symbol Options \(Sensor Menu\)"](#) on page 140

Inspection menu

Create and edit part programs through the inspection menu. To see this menu, right-click over any inspection name.

We use the term 'inspection' as a generic term for analyses, regions, enhancements, registrations, dimensions, etc. some items are grayed out if you do not have user access to those items, or if they do not apply to the current selection.

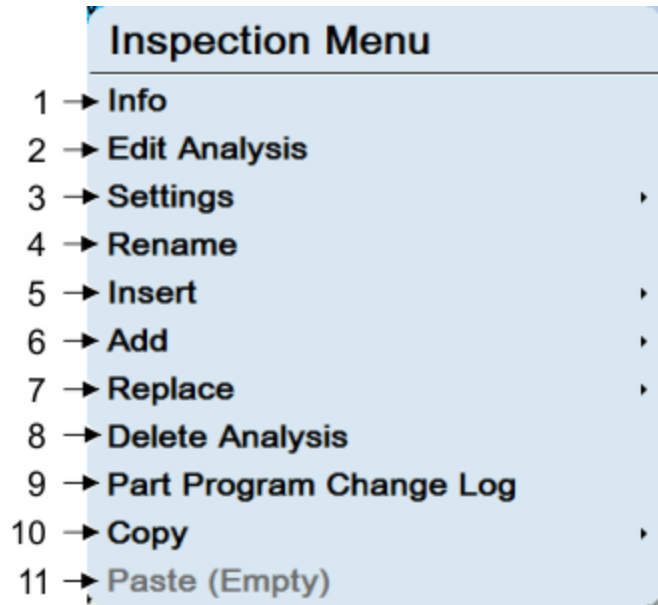

1 - Info

Display general information about the inspection. The "Specific Type" is the name used in the Inspections section in this guide

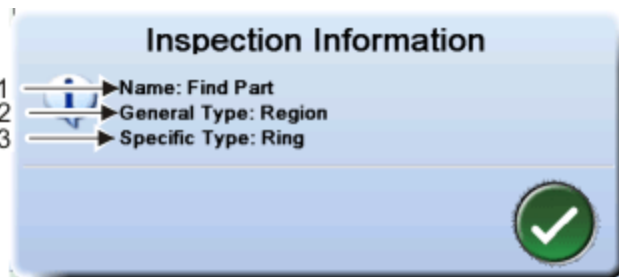

1 - Name - your name for the inspection | 2 - General type - Analysis, Region, Orientation, etc. | 3 - Specific type - sub-category (example, Ring, Polygon, or Measurement Region)

2 - **Edit** - Open the Inspection Editor - performs the same action as double clicking.

3 -Settings

Inspection sub-menu. Checked = enabled

Neckring Registration		
<input checked="" type="checkbox"/>	Is Inspection Enabled?	Yes ✓ No
<input checked="" type="checkbox"/>	Is Inspection Reject Enabled?	Yes ✓ No
<input type="checkbox"/>	Is Empty Pocket Check?	Yes No ✓
<input type="checkbox"/>	Exclude from Statistics?	Yes No ✓

Is Inspection Enabled? All of its dependent inspections are also enabled/disabled. The inspection name is grayed out when it is disabled.

Is Inspection Reject Enabled? If "No" is checked, then you can temporarily pass all parts regardless of whether they pass or fail the current inspection. Some items, such as Regions, do not have pass/fail criteria. This option is grayed out if reject is not applicable.

Is Empty Pocket Check? If "Yes" is checked, then inspection is being used as an empty pocket check.

Note: if you enable Empty Pocket Check, then Inspection Reject is automatically disabled. The system provides a warning that the rejector is being disabled.

Exclude from Statistics? If "Yes" is checked, then do not count failures of this inspection in the statistics. If "Yes" is checked, then:

- The inspection is not displayed in graphs
- If the inspection fails on a sensor, and no other inspection fails on the same sensor, the defect count is not increased for that sensor.
- If the inspection fails for a walk-by group and no other inspection fails in the same group, the defect count is not increased for that group.
- If the inspection fails and is the only inspection failing within a lane, the defect count is not increased for that lane.
- The inspection is still displayed in the results grid when you select the Reject Images button.
- The inspection name is still available in the drop-down selections when you select the SPC Graphs button.

- You can still view this inspection in the Inspections graph and Statistics Grid if you select the appropriate Display option (right-click over graph).
-

Start or Stop Auto-Learn (not shown) - [Present when Operator Trigger is enabled in Auto-Learn] Manually start or stop an Auto-Learn process. See Auto-Learn.

4 - Rename the inspection

5 - **Insert** - Add one item above the currently selected item.

6 - Add an inspection

7 - **Replace** - Replace the current item with a similar inspection.

8 - **Delete** - Delete the current item. If the item has other items below it (at a lower hierarchy), those items are deleted as well. Delete All Inspections deletes all the items in the inspection tree.

9 - **Part Program Change Log** - Display the **Part Program Change Log**. This lists the inspections and the edit history for each.

10 - Copy the selected inspection

11 - **Paste** - Paste the contents of the clipboard into the inspection list. The contents are pasted below the currently selected item.

Edit Regions

This view is available when you are editing a region. Double-click a region name in the inspection tree to see the region editor. You must have user permissions to edit.

In Region editor, you will not see anything happen if you select numbers 5, 6, or 7. The data set is changed, but you will not see the data set until you view the Inspection Editor.

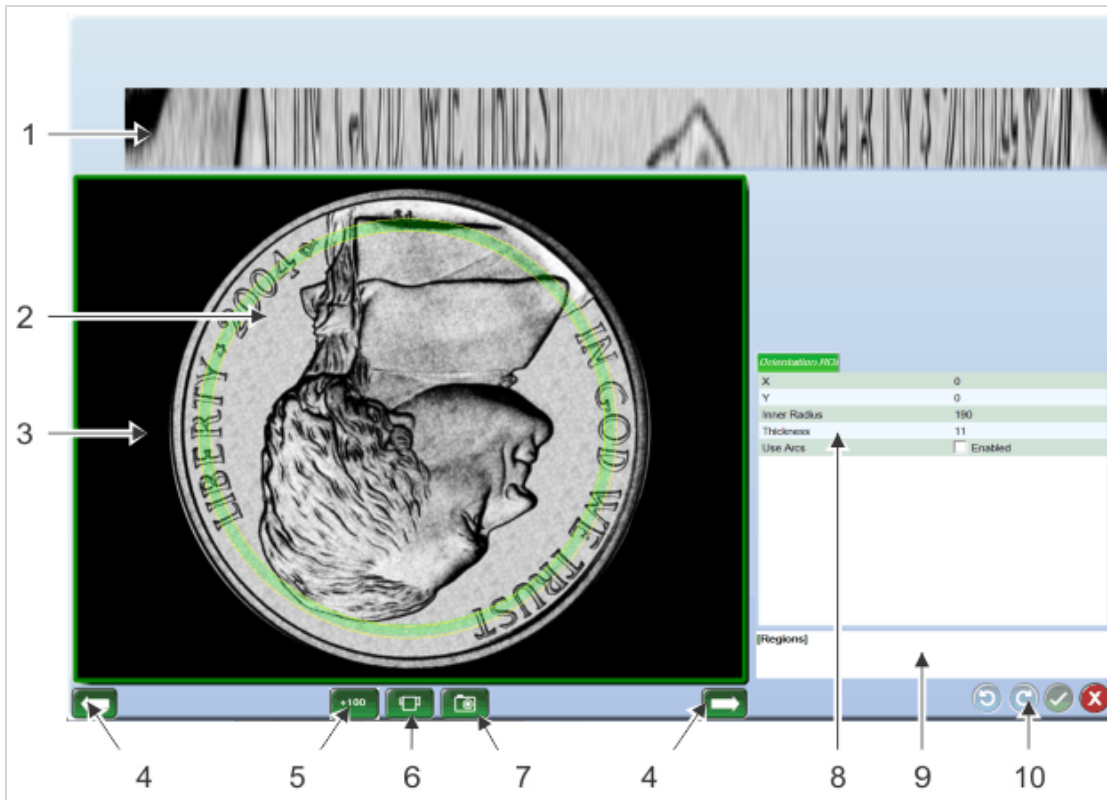

- 1 - Unwrapped region of interest (ROI)
- 2 - Part image
- 3 - Editable region
- 4 - Previous and Next image
- 5 - Get 100 new images
- 6 - Refresh data set
- 7 - Snap one image
- 8 - Edit parameters
- 9 - Parameter description window
- 10 - Undo/ Redo/ Accept/ Cancel

Edit Inspections

Edit an inspection. You must have user permissions to edit.

The Retro-Spec graph at the top of the screen is described separately.

1 - Unwrapped region of interest (ROI)
2 - Part image
3 - Previous and next image
4 - Get 100 new images
5 - Refresh data set
6 - Snap one image
7 - Inspection parameters
8 - Parameter description window
9 - Results box

Edit Parameters

You can change options that will alter the outcome of an inspection. You must have user permissions to edit. Double-click the inspection name in the inspection tree to edit.

Parameter	Value
Search Vector Count	105
Search Direction	<input checked="" type="checkbox"/> Flipped
Radial Tolerance	4
Diagnostics	<input type="checkbox"/>
Show Edges	<input checked="" type="checkbox"/> Enabled
Reject Limits	<input type="checkbox"/>
Qualifying Percent Limits	46.88 .. 68.68

- 1) Inspection tabs
- 2) Adjust numeric values
- 3) Check box to enable or disable the feature
- 4) Backwards R
- 5) Column division

1) **Inspection tabs** - Select a tab to adjust parameters. The orange tab contains the parameters that can be adjusted with the bars on the Retro-Spec graph. The tabs depend on the inspection and its relationship within the inspection tree.

Adjust numeric values

Large Slider - Use a sliding bar. Changes are also applied to the red and yellow sensitivity bars in the Retro-Spec graph. If the parameter has an upper and lower limit, portions of the bar are displayed in different colors, as shown below:



Red = failure limit. A part value that falls in the red zone fails inspection.

Yellow = warning limit. A part value that falls in the yellow zone is tagged as a warning level part.

Green = passing. A part value that falls in the green zone passes (at least this parameter).

Numeric Text Entry - Type in a specific number. You can use the +1 and -1 feature to make minor adjustments.

4) **Backwards R** - The current parameter can be adjusted in the Retro-Spec graph (example: the red and yellow limits bars).

5) **Column division** - This line is not actually displayed. You can see Large Slider AND numeric entry pad if you select in the left column, or just the numeric entry pad if you select in the right column (this only applies if Numeric Input setting = both. See [Editor Options](#)).

Editor Options

Right-click over the parameters menu to see the Editor Options. Checked = enabled

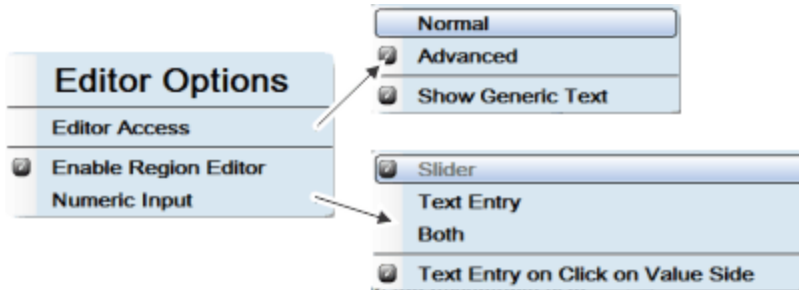

Editor Access

Normal - display the normal menus (for most users)

Advanced - display the advanced parameters (for power users)

you must have the appropriate permissions to see the advanced parameters: "Access advanced inspection parameters"

Show Generic Text - default Intellispec names.

Enable Region Editor - Available when the inspection has an associated region that can be modified.

Numeric Input

Slider = Large Slider as described in ["Edit Parameters" on the previous page](#)

Text Entry = Numeric Text Entry

Both = both Large Slider and Numeric Text entry. After you make changes, select the OK button to close them.

Text entry on click on value side = if you select an item the right column of the menu, you will see only the Numeric Text Entry box, even if you have Both checked

Result Options

There is additional information for the Results Box. Right-click to see the menu. Checked = enabled

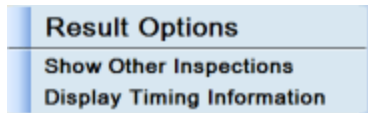

Show Other Inspections - Shows whether a part passed or failed other inspections on the current sensor. Right-click the menu again to see the option to hide good inspections. Double-click any inspection to show the Retro-Spec graph and images for that inspection.

Display Timing Information - Displays timing information for each inspection on the current sensor and the total time in milliseconds.

Retro-Spec Display

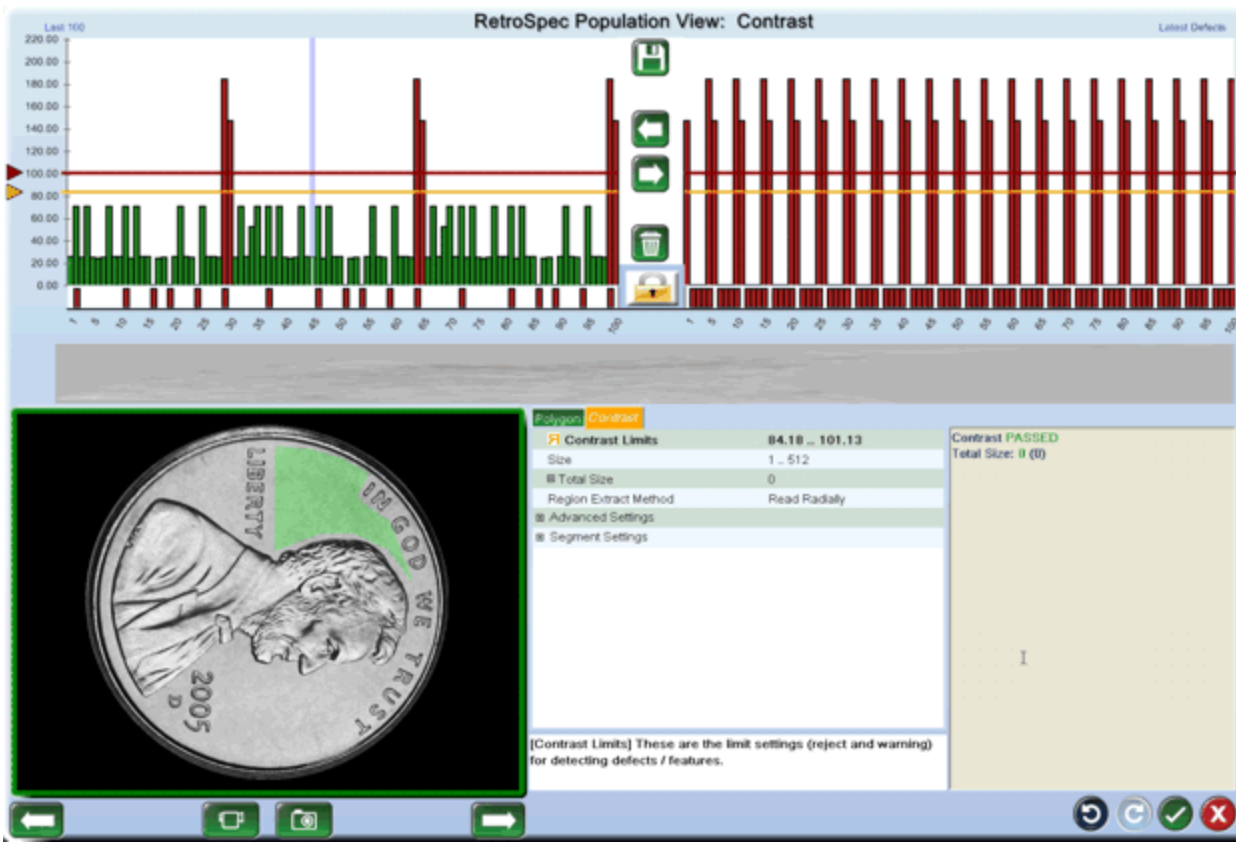

Double-click an inspection name in the inspection tree to see the Retro-Spec display. There are two views available for the graph area of the screen: "Retro-Spec Population View" on the next page and "Retro-Spec Part View" on page 155.

Retro-Spec Population View

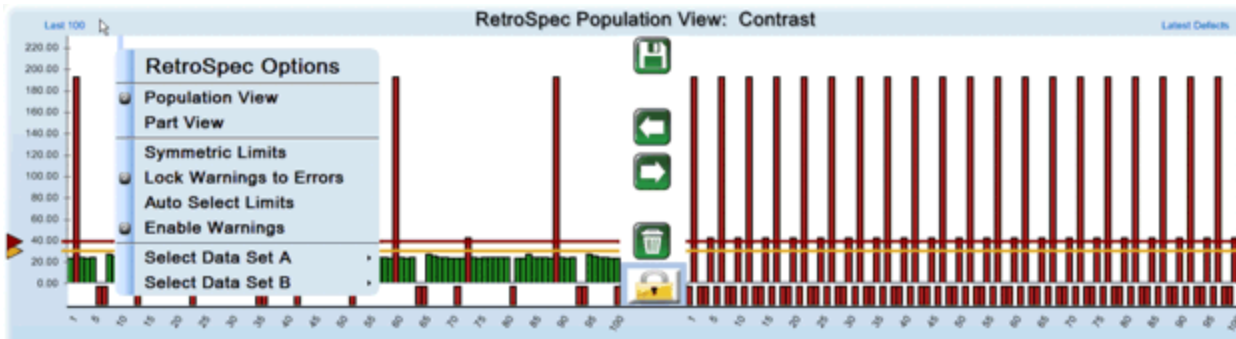

- Each peak is a different part. Red peaks are failed parts, green peaks are passed parts.
- The left side of the graph displays up to the last 100 parts that were inspected
- The right side of the graph displays up to the last 100 rejected parts
- Click on any peak to display the Part View for that part
- Right-click on the graph to select between the Part View and the Population View

Retro-Spec Options

Right-click the Retro-Spec graph to see the Retro-Spec options menu.

some options are not displayed if they are not applicable to the current inspection.

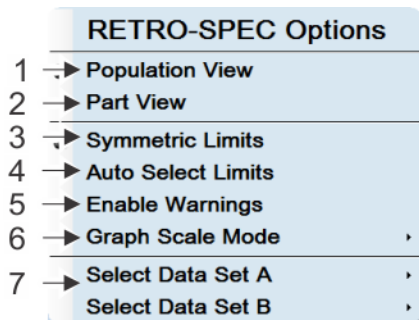

1 - **Population View** - Display the Retro-Spec population view graph.

2 - **Part View** - Display the Retro-Spec part view graph.

3 - **Symmetric Limits** - When the Retro-Spec graph has upper and lower limits (two red bars and two yellow bars), this option keeps the upper and lower limits the same distance from nominal.

Lock Warnings to Errors - [If warnings are enabled] Locks the yellow warning bar to the red reject bar in the Retro-Spec graph, keeping them the same distance apart.

4 - **Auto Select Limits** - Automatically adjusts warning and reject levels to make all parts in the data set pass.

5 - **Enable Warnings** - Provides a warning level (yellow) sensitivity bar. A warning does not reject parts, but indicates that the process is approaching the reject status. When you enable warnings, they are enabled for all inspections for the current sensor.

6 - **Graph Scale Mode** - Change the height scale of the graph. Limits Only displays part parameter values up to and including the current inspection limits. This is useful when you want to zoom in on data without extra lines on the graph. Note that the limit lines may not be displayed on the graph. As soon as you change the parameter limits from the menu, the limit lines are displayed again on the graph. Limits and Data is the default mode that displays all the inspection data plus the limit lines.

7 - **Select Data Set A or B** - For each Data Set, you can select what you want to display. You can choose files that have been previously saved to the computer. See information about Saving Images. See also Freeze on Defect Image in Retro-Spec.

[not shown] **Select Parameter** - Choose a graph to display. This is available for some inspections, such as Measurement and BMID inspections.

Retro-Spec Part View



- The Part View displays a single part view. Each peak shows the contrast as the inspection moves from 0° (at left), to 360° (at right).
- Green peaks are acceptable; red peaks are where the contrast has exceeded limits.
- The height or amplitude of each peak reflects the amount of contrast (how dark or light change)
- The width of each peak reflects the physical size of the change (below the red peaks are the same width as the light and dark marks they represent)

1) Unwrapped region - Below the graph is a display of the inspection region unwrapped. The degrees represent where the unwrapped region begins and ends.

2) Sensitivity slide bar - This is the inspection's primary sensitivity parameter and is adjusted up (less sensitive) or down (more sensitive) by clicking on the bar or arrow at the left and dragging it to the desired position.

Unwrapped Region of Interest Options

Right-click in the Unwrapped Region of Interest to display this menu. Checked = enabled

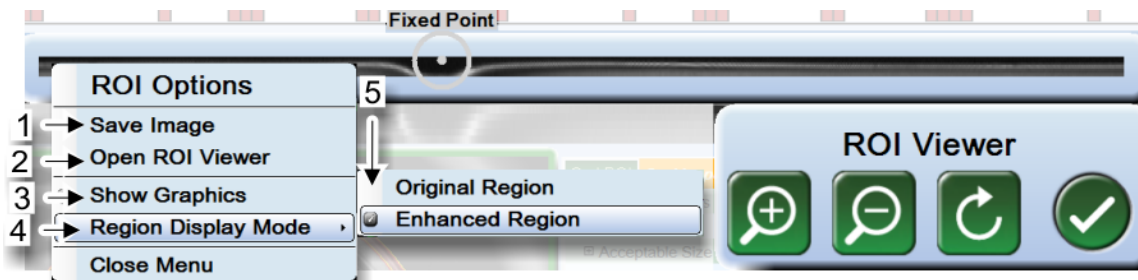

- 1) Save Region of Interest Image
 - 2) **Open ROI Viewer** - Display the unwrapped region at full resolution. Select a rotate button to change the orientation of the unwrapped ROI image.
 - 3) Show Graphics - no effect
 - 4) **Region Display Mode** - Show the original region, or the enhanced region if you use an enhancement in the part program.
- [not shown] **Region Selected** - (Only available if the inspection has more than one region; example: Fill Height) Select which region to display.

Part Program Change Log

The part program change log lists the inspections and the edit history for each. You can view all inspections from one sensor, other sensors, or other part programs. This is helpful if you want to see the previous settings for an inspection.

Part Program Change Log

Inspection: Undefined Show Other Inspections

Part Program: Measurement_test Show Other Part Programs

Sensor: Undefined Show Other Sensors

Roll Back Difference Details Filter

Type	Time Stamp	User	Camera/Sensor	Inspection	Parameter	Before	After
Create	2011-02-15 16:13:57	Administrator	Nickel	Ring			
Create	2011-02-15 16:12:18	Administrator	Nickel	Ring	Inner Radius	25	189
Edit	2011-02-15 16:12:48	Administrator	Nickel	Ring	Thickness	50	50
Create	2011-02-15 16:12:57	Administrator	Nickel	Radial Edge	Target Size	100	230
Edit	2011-02-15 16:13:36	Administrator	Nickel	Radial Edge	Qualifying Percent Limits	E:25.0 W:50.0 G	E:32.71 W:47.31 G
Create	2011-02-15 17:17:21	Administrator	Nickel	Measurement	Feature Type	Light Feature	Borders: Both Light
Edit	2011-02-15 17:17:21	Administrator	Nickel	Measurement	Inner Diameter Enabled	No	Yes
Edit	2011-02-15 17:17:21	Administrator	Nickel	Measurement	Width Enabled	No	Yes
Edit	2011-02-15 17:17:21	Administrator	Nickel	Measurement	Width Units	pixel	Custom unit
Edit	2011-02-15 17:17:21	Administrator	Nickel	Measurement	Width Nominal Value	53.0	26.5
Edit	2011-02-15 17:17:21	Administrator	Nickel	Measurement	Width Min/Max	E:50.0 W:W-10.0 G:30555.0 G:0.0 W:W:0.0 E:25.0 W:W-25.17 G:(26.5) G:0.0 W:W:0.77 E	
Edit	2011-02-15 17:17:21	Administrator	Nickel	Measurement	Width Average	E:50.0 W:W-10.0 G:30555.0 G:0.0 W:W:0.0 E:28.5 W:W-28.5 G:(26.5) G:0.0 W:W:0.0 E	
Edit	2011-02-15 17:17:21	Administrator	Nickel	Measurement	Width Continuity	E:50.0 W:W-10.0 G:18.0 W:W:0.0 E:40.76 W:W-8.65 G:3.83 W:W:4.82 E	
Edit	2011-02-15 17:17:21	Administrator	Nickel	Measurement	Width Range	G:53.0 E	G:11.85 E
Create	2011-03-01 18:03:37	Administrator	Nickel	Clipping	Use Clipping	No	Yes
Edit	2011-03-01 18:05:17	Administrator	Nickel	Clipping	Use Clipping	No	Yes
Create	2011-03-01 18:05:08	Administrator	Nickel	Stretch Grayshades			

To view the part change log:



- Go to Sensor Overview mode.
- Right-click over an inspection name and select Part Program Change Log from the Inspection menu. If the current inspection has never been changed since it was set up, no data is displayed.
- Select any of the available check boxes to view other inspections, inspections from other part programs, or inspections from other sensors. Some boxes are dependent on others; for example, you must select a dark gray check box before a light gray check box becomes active.

Type	Time Stamp	User	Part Program	Inspection
Create	2010-09-20 08:26:29	Tricia	Penny1	

To view a full column width, select and drag the column title to re-size that column.

Optimize

The Optimize feature automatically sets the optimum settings for many inspection parameters. It is processor-intensive and must be done off-line. For this to work correctly, ensure that you have moved all acceptable images to the left side of the Retro-Spec graph (Set A), and the defect images to the right side of the graph (Set B). Optimize is available under the Advanced Settings.

To use the Optimize feature:

1. Make sure the Retro-Spec graph is in Population view: right-click on the graph to select Population View.
2. Load a set of good images into Data Set A

Next load a set of images of bad parts into Data Set B. These parts should have defects in the current inspection's region of interest.

To finish setting up the Optimize feature:

1. In the Contrast menu, choose the Defect Type: light, dark, or both.
2. Adjust the Acceptable Size parameter to catch the size of defect you want to detect.
3. Click the Optimize button. The system will analyze the part sets and determine the best settings to pass the good parts while failing the bad parts. Wait till the optimization process is complete - this may take several seconds.
4. Scroll through the images from the Retro-Spec graph to determine whether the good parts are still passing and the bad parts are failing. You should see good parts on the left side of the graph, and bad parts on the right side of the graph.
5. Test the inspection by loading more images. You can make slight adjustments in the Contrast menu if necessary.

Module 9 Empty Bottle Inspections - Introduction

The next sections describe how to set up the standard set of inspections for empty bottles on the Intellispec system. The size, placement, and typical sensitivity settings are shown for each region of the bottle.

This page left blank intentionally

Module 10 Inspections for Base Camera

This section explains how to set up the inspections. Note that your inspections may be different, depending on your specific part, plant, and process requirements.

The picture below shows an image with all base inspection regions. We will set these up one at a time.

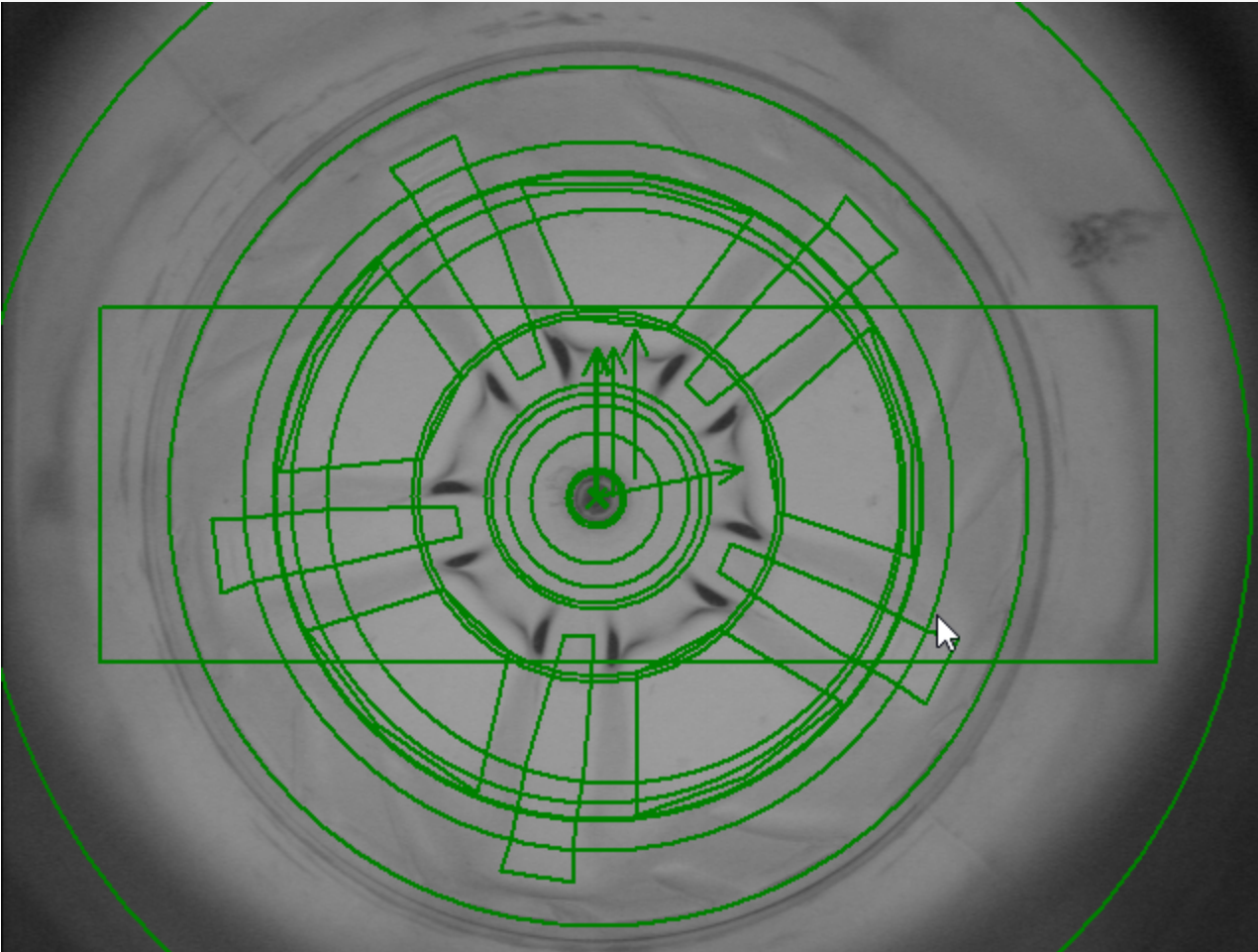

Create the Base Inspection Tree

The steps below will guide you through the process of building the Base Inspection Tree, while ensuring that the directory links are connected correctly. First add the inspections, then rename them to something that makes sense to you. Note that we will set up the regions and parameters later. For now, we will just build the inspection tree.

Note for all steps: when you add the inspection, you can rename it immediately.

After each step, select the OK button to save changes, and the Exit button to exit the inspection.

This is how the inspection tree will look

Steps to add the inspections

Note: ROI = Region of Interest

- 1 Inspections
- 2 Base Empty Pocket ROI
- 3 Base Empty Pocket
- 4 True Center ROI
- 5 Stretch Grayshades
- 6 True Center
- 7 Outer Base ROI
- 8 Outer Base Inspection
- 9 Spoke Defects ROI
- 10 Clipping
- 11 Spoke Defects Inspection
- 12 Orientation ROI
- 13 Orientation
- 14 Foot ROI
- 15 Foot Inspection
- 16 Between Foot ROI
- 17 Between Foot Inspection
- 18 Pearling ROI
- 19 Pearling Inspection
- 20 Gate Registration ROI
- 21 Gate Registration
- 22 Gate ROI
- 23 Gate Inspection
- 24 Around Gate ROI
- 25 Around Gate Inspection
- 26 Base Fold ROI
- 27 Base Fold Inspection
- Off-Center Gate Inspection

1. **Inspections** Right-click Inspections. Add | Region | Ribbon. Rename it Base Empty Pocket ROI.
2. Right-click Base Empty Pocket ROI. Add | Analysis | Contrast. Rename it Base Empty Pocket.
3. **Inspections** Right-click Inspections. Add | Region | Ring. Rename it True Center ROI.
4. Right-click True Center ROI. Add | Enhancement | Stretch Grayshades.
5. Right-click True Center ROI. Add | Registration | Hough. Rename it True Center.
6. Right-click True Center. Add | Region | Ring. Rename it Outer Base ROI.
7. Right-click Outer Base ROI. Add | Analysis | Contrast. Rename it Outer Base Inspection.
8. Right-click True Center. Add | Region | Ring. Rename it Spoke Defects ROI.
9. Right-click Spoke Defects ROI. Add | Enhancement | Clipping.
10. Right-click Spoke Defects ROI. Add | Analysis | Contrast. Rename it Spoke Defects Inspection.
11. Right-click True Center. Add | Region | Ring. Rename it Orientation ROI.
12. Right-click Orientation ROI. Add | Orientation | Pattern Match. Rename it Orientation.
13. Right-click Orientation. Add | Region | Polygon. Rename it Foot ROI.
14. Right-click Foot ROI. Add | Analysis | Contrast. Rename it Foot Inspection.
15. Right-click Orientation. Add | Region | Polygon. Rename it Between Foot ROI.
16. Right-click Between Foot ROI. Add | Analysis | Contrast. Rename it Between Foot Inspection.
17. Right-click Orientation. Add | Region | Ring. Rename it Pearling ROI.
18. Right-click Pearling ROI. Add | Analysis | Contrast. Rename it Pearling Inspection.
19. Right-click True Center. Add | Region | Ring. Rename it Gate Registration

Inspection tree- repeated

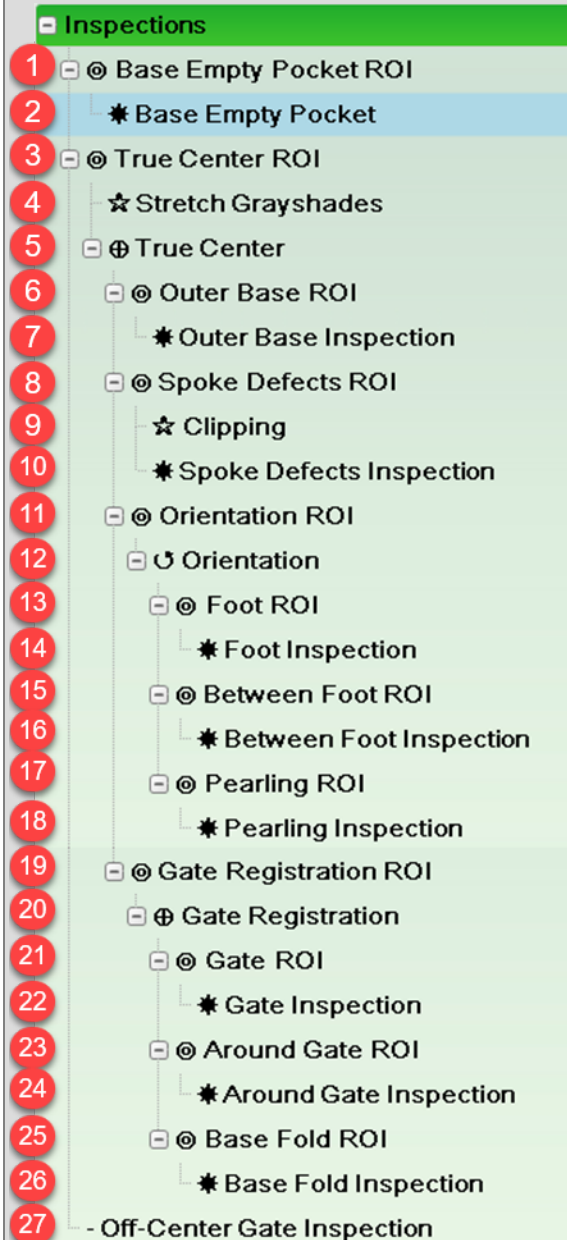

ROI.

20. Right-click Gate Registration ROI. Add | Registration | Feature. Rename it Gate Registration.
21. Right-click Gate Registration. Add | Region | Ring. Rename it Gate ROI.
22. Right-click Gate ROI. Add | Analysis | Contrast. Rename it Gate Inspection.
23. Right-click Gate Registration. Add | Region | Ring. Rename it Around Gate ROI.
24. Right-click Around Gate ROI. Add | Analysis | Contrast. Rename it Around Gate Inspection.
25. Right-click Gate Registration. Add | Region | Ring. Rename it Base Fold ROI.
26. Right-click Base Fold ROI. Add | Analysis | Ambient. Rename it Base Fold Inspection.
27. Right-click True Center ROI. Add | Dimension | Distance. Rename it Off-Center Gate Inspection.

Your inspection tree should look similar to that shown on the left.

Place the Empty Pocket ROI

An empty pocket inspection must be applied if your system is using a PDX. The Empty Pocket is used to determine if the bottle is in the gripper fingers. If so it allows the inspections to be performed; if not, it stops the inspections from being done.

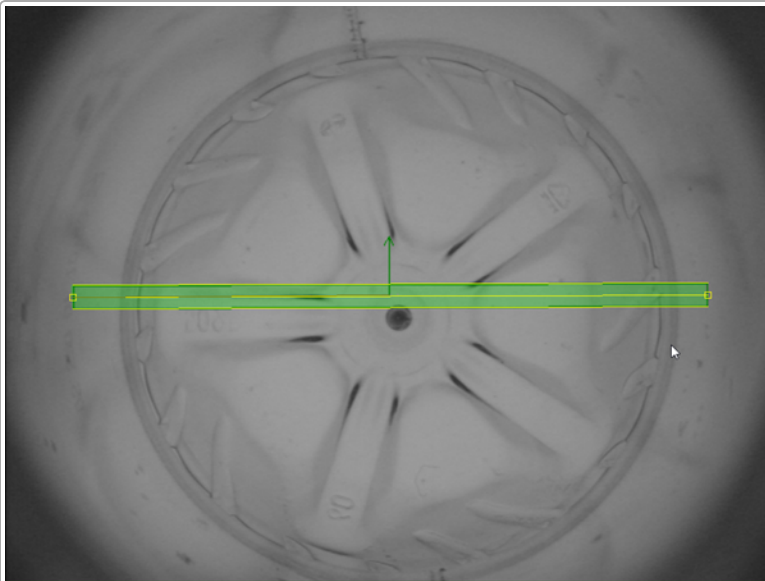

Double-click Base Empty Pocket ROI in the inspection tree.

If the Ribbon is not already set on the image: it says NEW RIBBON (Click to add points). Click in the image to place two points to span most of the image.

Then right-click over the image and select Complete New Ribbon. A ribbon with yellow lines will be displayed on the image.

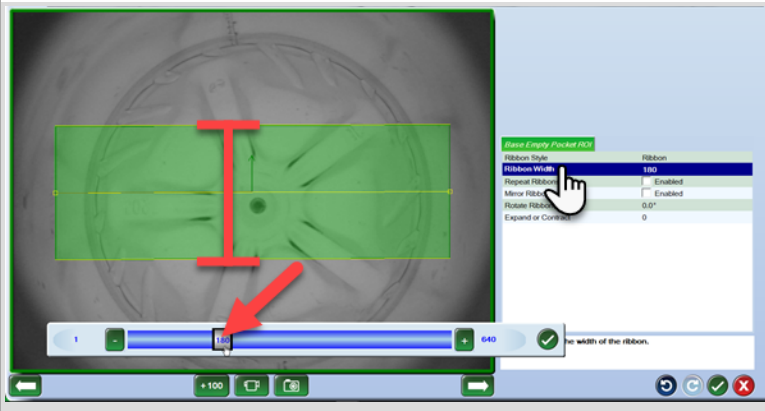

We want the ribbon to cover more area over the base where we expect to see dark pixels from the gate and feet.

To cover more of the image area:

Select Ribbon Width and make it wider. In our example, we used 180 for Ribbon Width.

Leave the remaining parameters at the default values. Your values may vary, based on your part and system setup.

 Select the OK button to save changes and exit.

Set up the Base Empty Pocket Inspection

We will set up this inspection to detect some dark pixels over the gate and feet area. If these dark pixels do not appear, then the system will know that there is no bottle present, and therefore not run any further inspections.

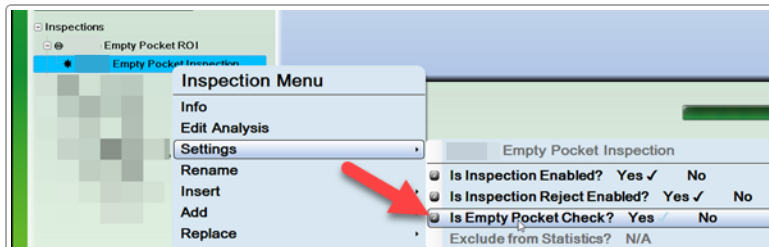

In the Inspection Tree, right-click over the Base Empty Pocket. Select Settings | Is Empty Pocket Check? Click to enable it.

The system will give a warning that rejecting is off. This is OK.

The name of the Empty Pocket inspection will have a blue background in the inspection tree.

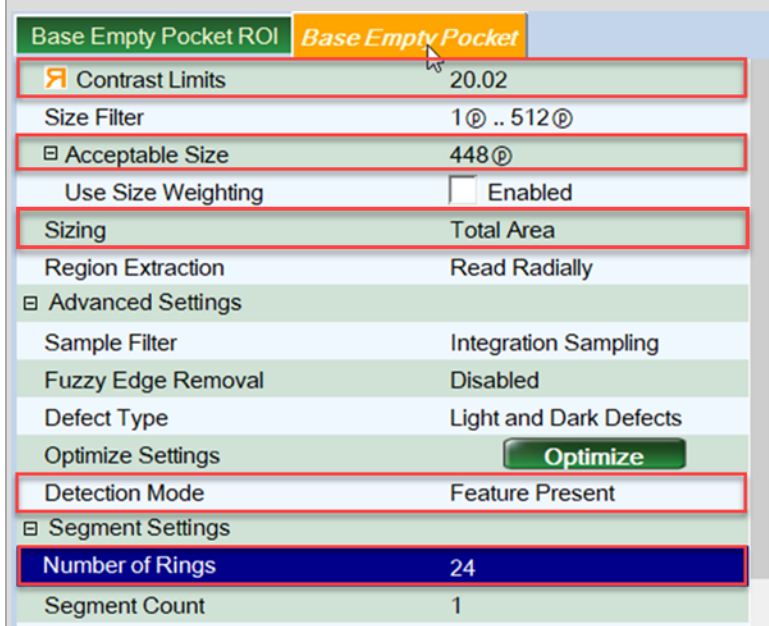

Double-click Base Empty Pocket (in the inspection tree) to edit it.

If you need to see images, put the lane online to acquire several images. Take the lane offline, and select the [+100] button below the image.

To set the parameters:

1. Set Contrast Limits to approximately 20.
2. Set Acceptable size to approximately 448. This allows the system to accept many pixels, to consider that a part is present.
3. Set Sizing to Total Area. This allows the system to count the total number of pixels instead of groups of pixels.
4. Set Detection Mode to Feature Present. This means that a feature should be present, and if it is not, then the absence of a feature means there is no part.
5. Set the Number of Rings to 24. This makes the inspection more sensitive.
6. Leave the remaining parameters at the default values. Your values may vary, based on your part and system setup.

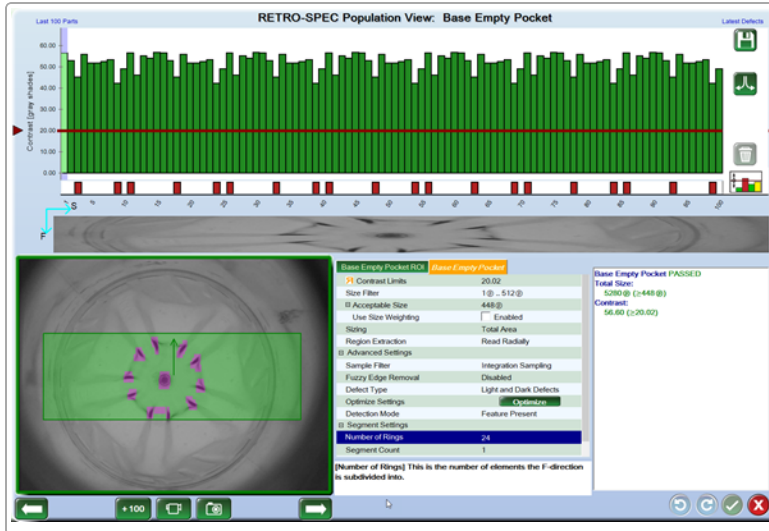

Images with parts in the field of view should pass the inspection. If a part was missing, it would fail.



Select the OK button to save changes and exit.

Place the True Center ROI

We will set up the Region of Interest (ROI) so that the system knows where to search for the "true center" of the base. Since bottles change position slightly from part to part, the True Center Registration finds the center for each bottle. Once this point is found, the remaining inspections are run to inspect the base.

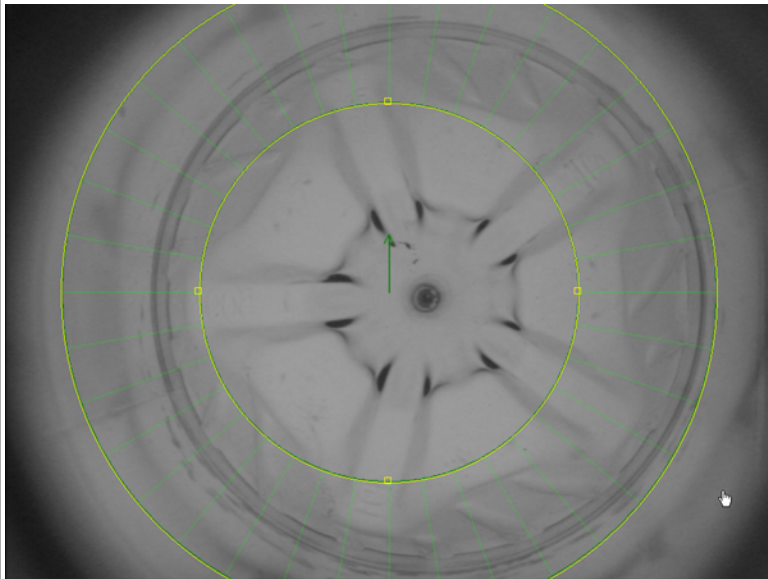
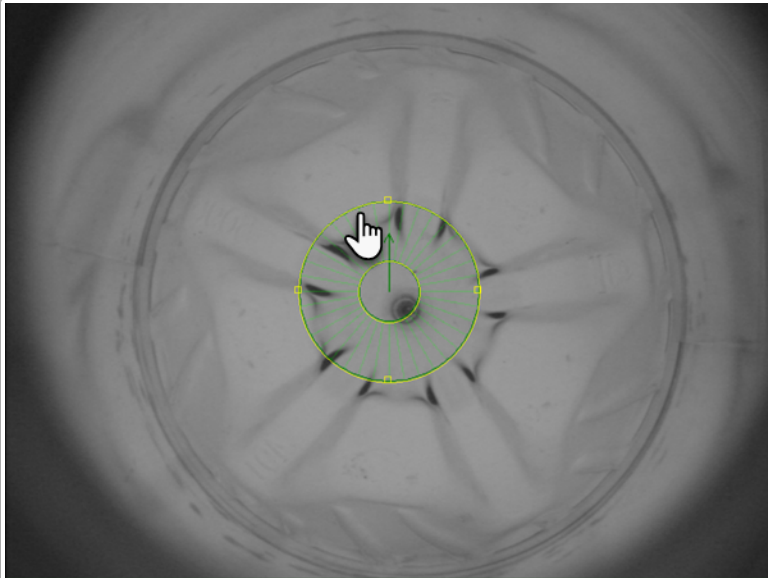

Double-click True Center ROI in the inspection tree to edit it.

To edit the region:

1. Click inside the default region.
2. Select one of the yellow boxes on the outer region border, and drag it outside of the perimeter of the base. It is OK for the region to fall outside of the inspection window (in a Hough registration, which is what we are using).
3. Click in the center of the region. You will see yellow boxes on the inner region border.
4. Drag one of the yellow boxes so that the inner border falls inside of the perimeter of the outer base.
5. Scroll through a few images to make sure the outer base perimeter falls inside the inspection region. You may need to make the inner region smaller to accommodate all bottles.
6. Leave the remaining parameters at the default values. Your values may vary, based on your part and system setup.

True Center ROI	
X Offset	-11
Y Offset	9
Inner Radius	145
Thickness	177

7.  Select the OK button to save changes and exit.

Set up the Base Inspection Enhancement

We are using Stretch Grayshades to increase the image contrast, so that the system can locate the perimeter of the base.

Note: your system may have this enhancement disabled, based on your part. On some systems, the inspections work better without this enhancement.

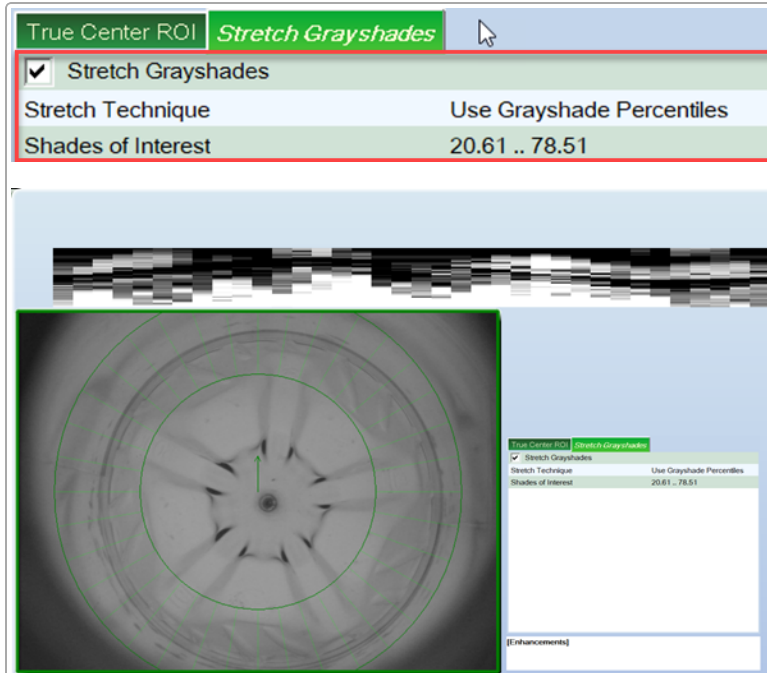

Double-click Stretch Grayshades to edit it.

To set up the enhancement:

1. Pay attention to the parameters (outlined in red) shown to the left. Start with these settings, and adjust if needed for your part.
2. Leave the remaining parameters at the default values. Your values may vary, based on your part and system setup.
3.  Select the OK button to save changes and exit.

The unwrapped region of interest shows the effect of the enhancement.

Set up the True Center Registration

The Registration does the search for edges, to find the true center of the base.

True Center ROI	Stretch Grayshades	True Center	Target Circle
Edge Location			
Edge Polarity	Light-to-Dark		
Edge Gradient	0 .. 30		
Edge Delta	2		
Edge Size	2		
Use Subpixel	<input checked="" type="checkbox"/> Enabled		

Double-click True Center to edit it.

In the Edge Location menu, set Edge Polarity to Light-to-Dark. This allows the system to find only dark edges.

Pay attention to the parameters (outlined in red) shown to the left. Start with these settings, and adjust if needed for your part.

Edge Location	True Center ROI	Stretch Grayshades	True Center	Target Circle
Target Radius	232			
Learn	<input type="button" value="Learn"/>			
Adapting Target Radius	<input checked="" type="checkbox"/> Enabled			
Adaptation Range	3			

Go to the Target Circle tab.

Enable Adapting Target Radius. This increases the accuracy of finding the edges.

Click the Learn button. This allows the system to learn where the edges will fall.

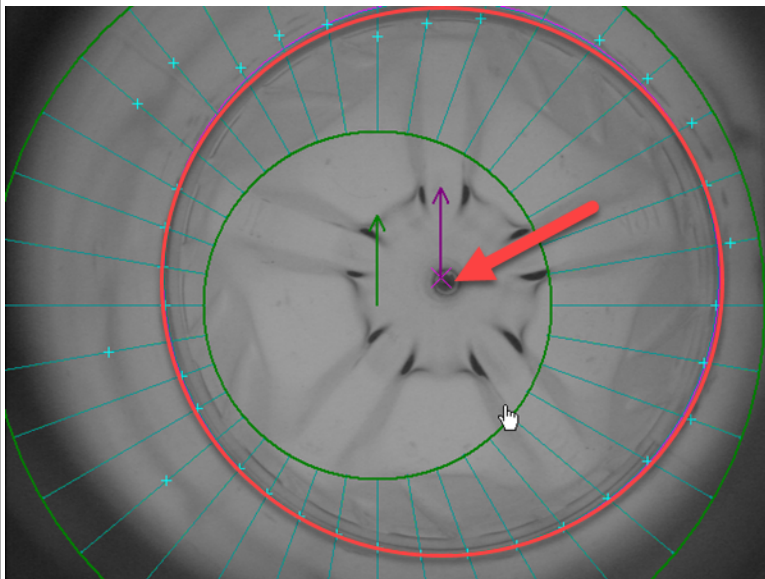

The system should now find the edge transitions on the outer base, and the center of the part.

! *Important: this is a critical step to make sure the following inspections work correctly. Be sure to test several parts and make sure the (approximate) gate is found as the center (if it is a good part). Make adjustments as needed.*

Leave the remaining parameters at the default values. Your values may vary, based on your part and system setup.

Select the OK button to save changes and exit.

Place the Outer Base ROI

We will set up the Region of Interest (ROI) to position the inspection on the outer base.

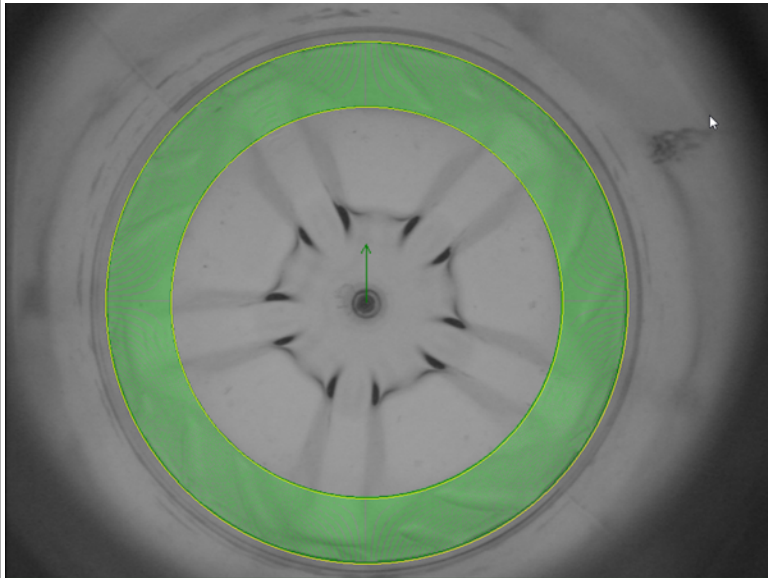

Double-click Outer Base ROI in the inspection tree to edit the region.

To edit the region:

1. Click inside the two circles of the default region.
2. Place the region on the outer base as shown.
3. Leave the remaining parameters at the default values. Your values may vary, based on your part and system setup.

Outer Base ROI	
X	0
Y	0
Inner Radius	163
Thickness	54
Use Arc Segments	<input type="checkbox"/> Enabled
Perimeter Type	Normal

4.  Select the OK button to save changes and exit.

Set up the Outer Base Inspection

We are using a Contrast inspection to find defects in the outer base.

The image shows the 'Outer Base Inspection' settings panel. The 'Contrast Limits' section is highlighted with a red border, showing a value of 21.68. Other settings include 'Size Filter' (1 @ .. 512 @), 'Acceptable Size' (0 @), 'Use Size Weighting' (disabled), 'Sizing' (Total Width), 'Region Extraction' (Read Radially), 'Advanced Settings' (Sample Filter: Integration Sampling, Fuzzy Edge Removal: Disabled, Defect Type: Light and Dark Defects, Optimize Settings: Optimize button, Detection Mode: Defect Detect), and 'Segment Settings' (Number of Rings: 20, Segment Count: 1). Below the settings is a 'RETRO-SPEC Population View: Outer Base Inspection' graph showing 'Last 100 Parts'. The graph has a y-axis labeled 'Gray (arbitrary)' from 0 to 60.00. A red horizontal line is drawn at approximately 21.68. The data is represented by green bars, with several taller red bars indicating defects. A hand cursor is pointing to the red line.

Section	Parameter	Value
Contrast Limits	Contrast Limits	21.68
	Size Filter	1 @ .. 512 @
Acceptable Size	Acceptable Size	0 @
	Use Size Weighting	<input type="checkbox"/> Enabled
Sizing	Sizing	Total Width
Region Extraction	Region Extraction	Read Radially
Advanced Settings	Sample Filter	Integration Sampling
	Fuzzy Edge Removal	Disabled
	Defect Type	Light and Dark Defects
	Optimize Settings	Optimize
	Detection Mode	Defect Detect
Segment Settings	Number of Rings	20
	Segment Count	1

Double-click Outer Base Inspection to edit it.

To set up the inspection:

1. Pay attention to the parameters (outlined in red) shown to the left. Start with these settings, and adjust if needed for your part.
2. Scroll through several images to make sure the inspection is passing or failing as desired.
3. You can move the red horizontal bar in the graph closer to zero to make the inspection more sensitive, or further from the center to make the inspection less sensitive.
4. Leave the remaining parameters at the default values. Your values may vary, based on your part and system setup.
5.  Select the OK button to save changes and exit.

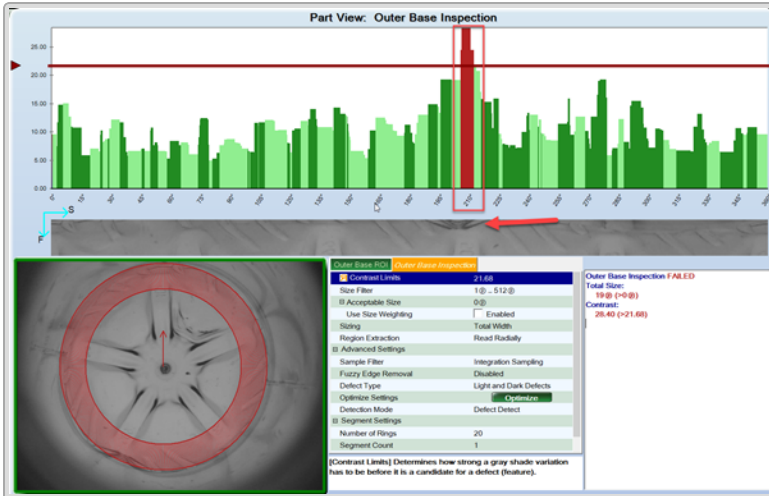

In this example, you can see the failure from the Part View graph. The system found a base fold that fell outside the limits we set.

Place the Spoke Defects ROI

We will set up the Region of Interest (ROI) to position the inspection for spoke defects.

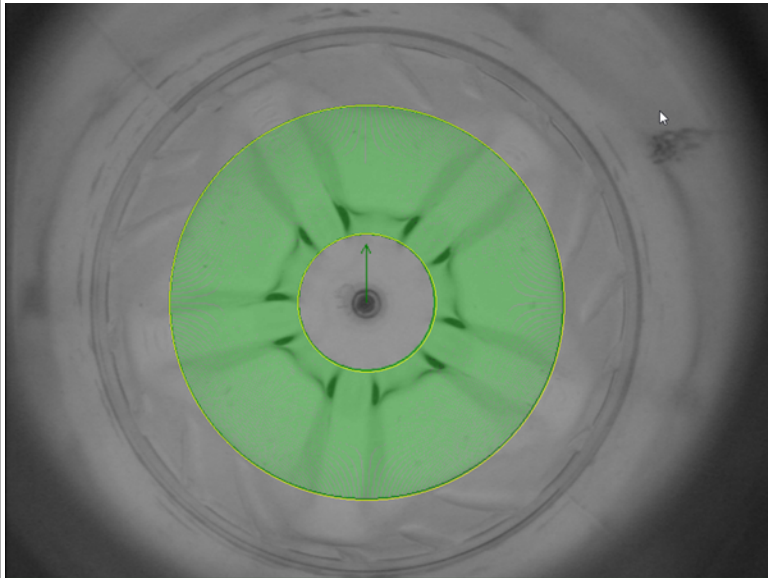

Double-click Spoke Defects ROI in the inspection tree to edit the region.

To edit the region:

1. Click inside the two circles of the default region.
2. Place the region to surround the spokes as shown.
3. Leave the remaining parameters at the default values. Your values may vary, based on your part and system setup.

Spoke Defects ROI	
X	0
Y	0
Inner Radius	57
Thickness	107
Use Arc Segments	<input type="checkbox"/> Enabled
Perimeter Type	Normal

4.  Select the OK button to save changes and exit.

Set up the Spoke Defects Enhancement

We are using Clipping to decrease the contrast between the spokes.

Note: Clipping may be disabled on your system, depending on your part. On some systems, the inspections work better without the enhancement.

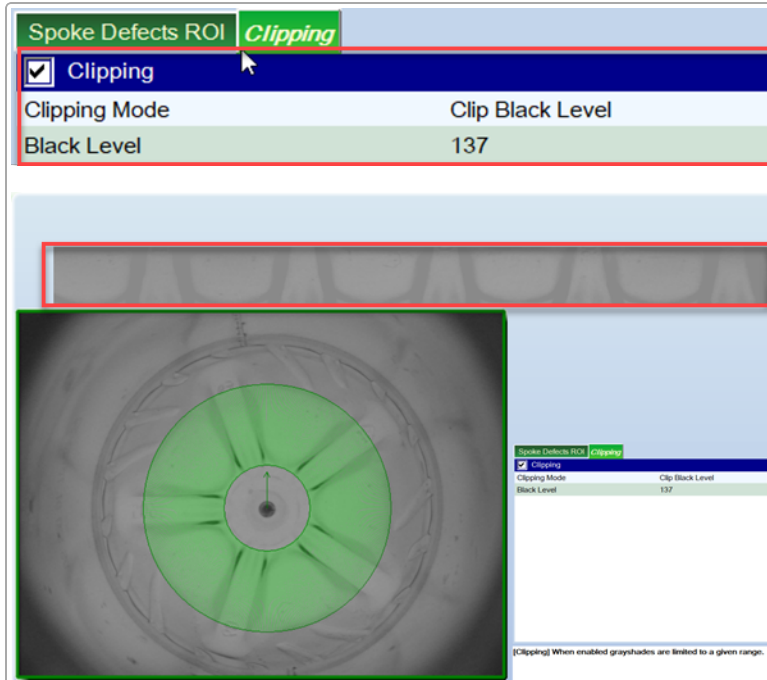

Double-click Clipping to edit it.

To set up the enhancement:

1. Pay attention to the parameters (outlined in red) shown to the left. Start with these settings, and adjust if needed for your part.
2. Leave the remaining parameters at the default values. Your values may vary, based on your part and system setup.
3.  Select the OK button to save changes and exit.

The unwrapped region of interest shows the effect of the enhancement.

Set up the Spoke Defects Inspection

We are using a Contrast inspection to find defects in the spokes area.

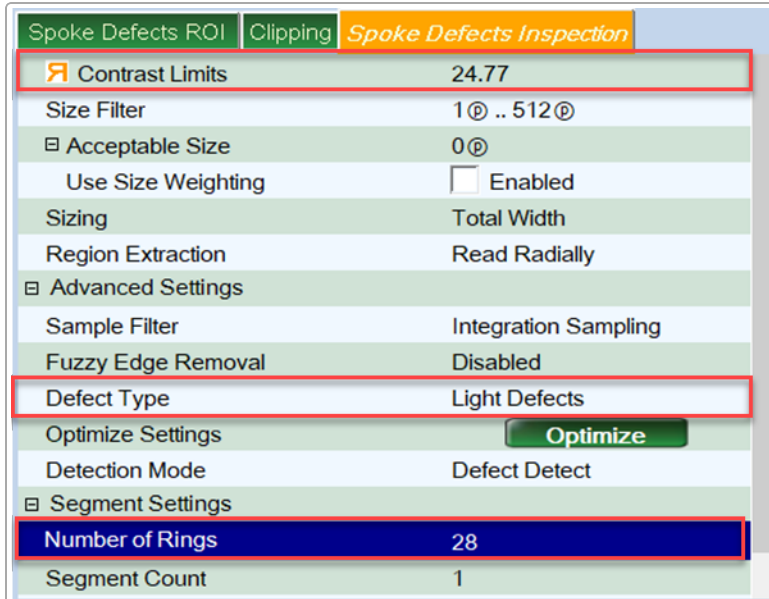

Spoke Defects ROI	Clipping	Spoke Defects Inspection
Contrast Limits	24.77	
Size Filter	1 @ .. 512 @	
Acceptable Size	0 @	
Use Size Weighting	<input type="checkbox"/> Enabled	
Sizing	Total Width	
Region Extraction	Read Radially	
Advanced Settings		
Sample Filter	Integration Sampling	
Fuzzy Edge Removal	Disabled	
Defect Type	Light Defects	
Optimize Settings	Optimize	
Detection Mode	Defect Detect	
Segment Settings		
Number of Rings	28	
Segment Count	1	

Double-click the Spoke Defects Inspection to edit it.

To set up the inspection:

1. Pay attention to the parameters (outlined in red) shown to the left. Start with these settings, and adjust if needed for your part.
2. Leave the remaining parameters at the default values. Your values may vary, based on your part and system setup.
3.  Select the OK button to save changes and exit.

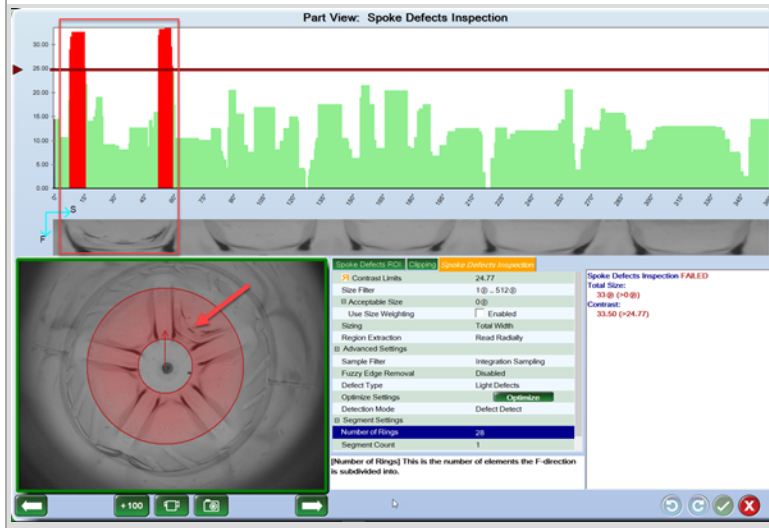

Part View: Spoke Defects Inspection

Spoke Defects Inspection FAILED

Total Size: 33.50 (>24.77)

Contrast: 33.50 (>24.77)

(Number of Rings) This is the number of elements the F-direction is subdivided into.

In this example, you can see the failure from the Part View graph. The system found a base fold that fell outside the limits we set.

Place the Orientation ROI

We will set up the Region of Interest (ROI) to determine the orientation of the part.

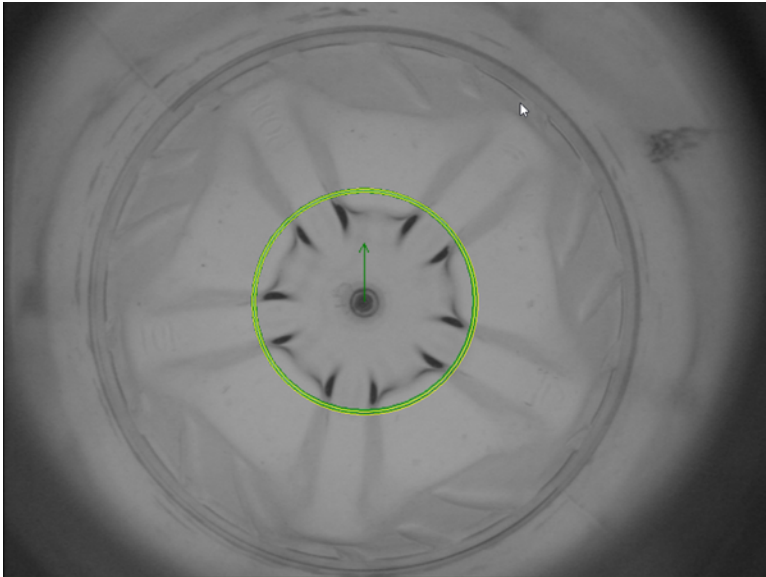

Double-click Orientation ROI in the inspection tree to edit the region.

To edit the region:

1. Click inside the two circles of the default region.
2. Place the region as shown.
3. Leave the remaining parameters at the default values. Your values may vary, based on your part and system setup.

Orientation ROI	
X Offset	0
Y Offset	0
Inner Radius	91
Thickness	3
Use Arc Segments	<input type="checkbox"/> Enabled
Perimeter Type	Normal

4.  Select the OK button to save changes and exit.

Set up the Base Orientation

We are using a Pattern Match orientation to find defects on and between the feet of the bottle. The system uses the bottle's geometry to place the inspections.

Orientation ROI	Orientation	
Symmetry Repeat	5	
Symmetry Start	1	
Radial Spacing	1	
Select Offset Angle	<input type="button" value="Select Angle"/>	
Offset Angle	25.19°	
Set Reference	<input type="button" value="→ ←"/>	
Show Orientation	<input checked="" type="checkbox"/> Enabled	
Part View Display	Show Pattern	
Show Pattern Match	<input type="checkbox"/> Enabled	
Region Extraction	Read Radially	
<input type="checkbox"/> Reject Limits		
<input checked="" type="checkbox"/> Pattern Match Confidence	30	

Double-click the Orientation to edit it.

To set up the orientation:

1. Set Symmetry Repeat to 5 (depending on your bottle). If your bottle's base has feet, then use the number of feet your bottle has.
2. Click the Set Reference button. The system will automatically compute the reference point based on your part and Offset Angle.
3. Click the Select Angle button. On the image, select a spot on the base that is repeatable from part to part. (see our example below) Click the Select Angle button again to save the selection. The system updates Offset Angle automatically.
4. Leave the remaining parameters at the default values. Your values may vary, based on your part and system setup.
5. Select the OK button to save changes and exit.

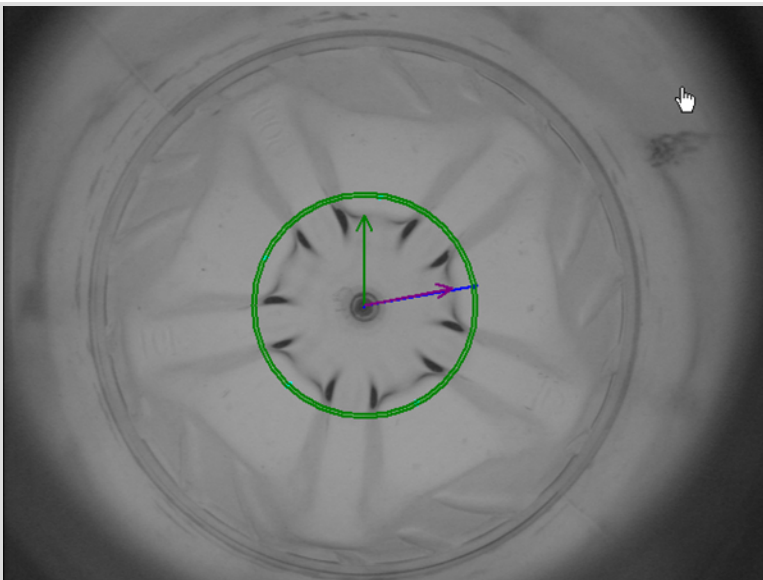

Orientation example.

Place the Foot ROI

We are using a Polygon region to place this inspection.

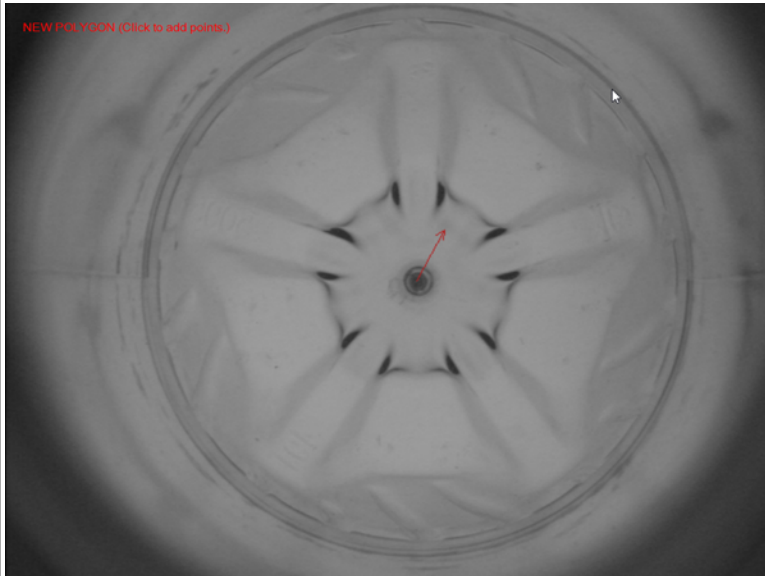

Double-click Foot ROI to edit it.

If this is your first time editing this region, it will say "New Polygon (click to add points)." First, set some parameters.

This region uses the orientation we set up previously to place the inspection on the feet.

To set up the menu:

1. In the Foot ROI menu, check Repeat Polygons to enable it.
2. Set Repeat Count to 5 (or the number you used in previous Orientation).

Foot ROI	
Repeat Polygons	<input checked="" type="checkbox"/> Enabled
Repeat Count	5
Rotate Polygon	0.0°
Expand or Contract	0
Perimeter Type	Normal

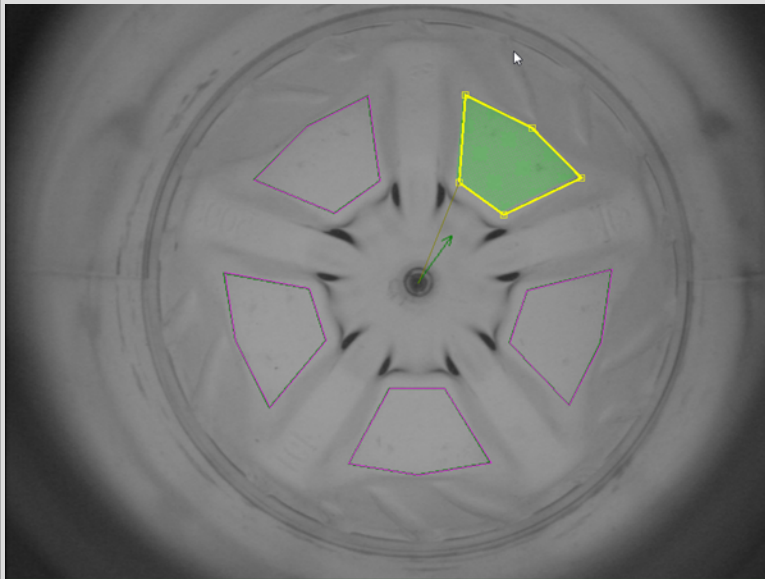

To place the regions:

1. Click in the image to place points to create a polygon to cover the foot, as shown. (It does not matter which point you place first)
2. Click again over the first point. This will close the polygon.
3. The system automatically repeats the region around the base.
4. *Note: if the polygons go outside the feet - overlapping darker areas, for example, then 1) make sure your True Center is working correctly, and 2) move the polygon points inwards so that the region is not too large.*
5.  Select the OK button to save changes and exit.

Set up the Foot Inspection

We are using a Contrast inspection to find defects in the feet.

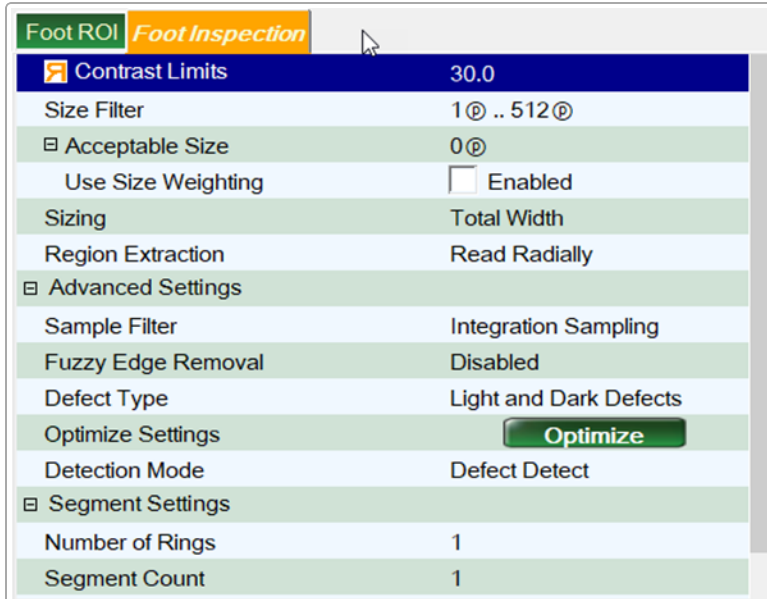

Foot ROI	Foot Inspection
Contrast Limits	30.0
Size Filter	1 @ .. 512 @
Acceptable Size	0 @
Use Size Weighting	<input type="checkbox"/> Enabled
Sizing	Total Width
Region Extraction	Read Radially
Advanced Settings	
Sample Filter	Integration Sampling
Fuzzy Edge Removal	Disabled
Defect Type	Light and Dark Defects
Optimize Settings	Optimize
Detection Mode	Defect Detect
Segment Settings	
Number of Rings	1
Segment Count	1

Double-click the Foot Inspection to edit it.

To set up the inspection:

1. For the most part, you can leave the parameters at the default values. Your values may vary, based on your part and system setup.
2.  Select the OK button to save changes and exit.

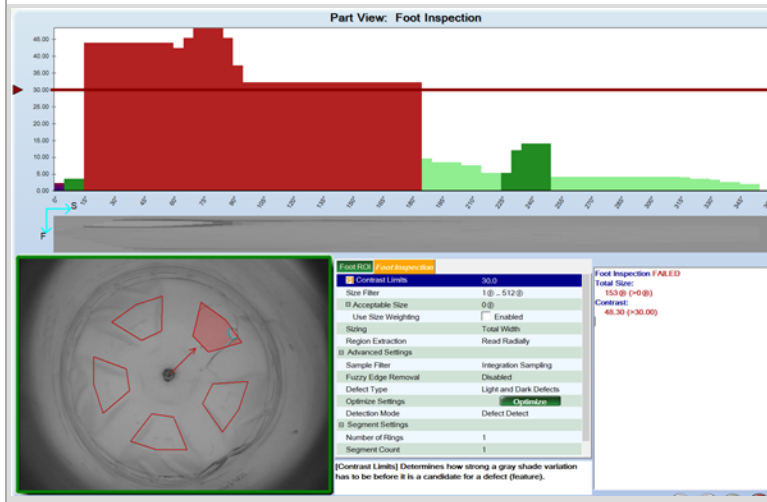

Part View: Foot Inspection

Foot Inspection FAILED
Total Size: 153 @ (-0 @)
Contrast: 48.30 (>30.00)

(Contrast Limits) Determines how strong a gray shade variation has to be before it is a candidate for a defect (feature).

In this example, you can see the failure from the Part View graph. The system found a base hole.

Place the Between Foot ROI

We are using a Polygon region to place this inspection.

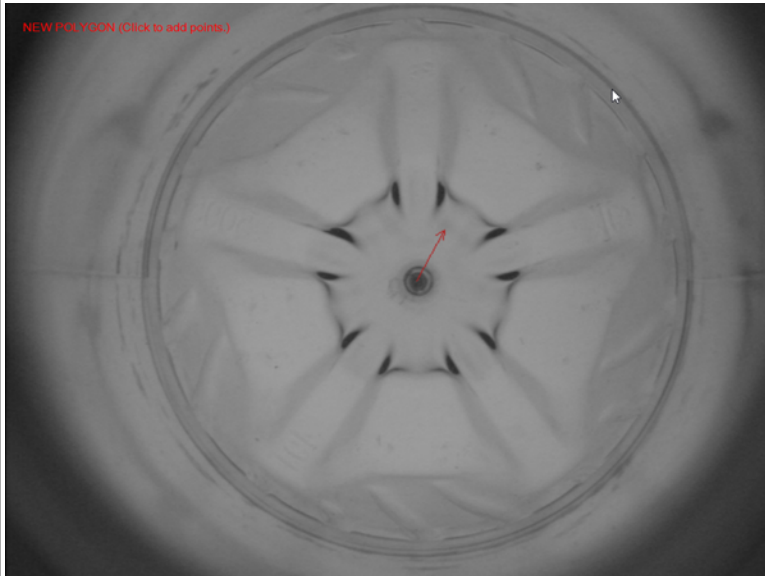

Double-click Between Foot ROI to edit it.

If this is your first time editing this region, it will say "New Polygon (click to add points)." First, set some parameters.

This region uses the orientation we set up previously to place the inspection between the feet.

To set up the menu:

1. In the Between Foot ROI menu, check Repeat Polygons to enable it.
2. Set Repeat Count to 5 (or the number you used in previous Orientation).

Between Foot ROI	
Repeat Polygons	<input checked="" type="checkbox"/> Enabled
Repeat Count	5
Rotate Polygon	0.0°
Expand or Contract	0
Perimeter Type	Normal

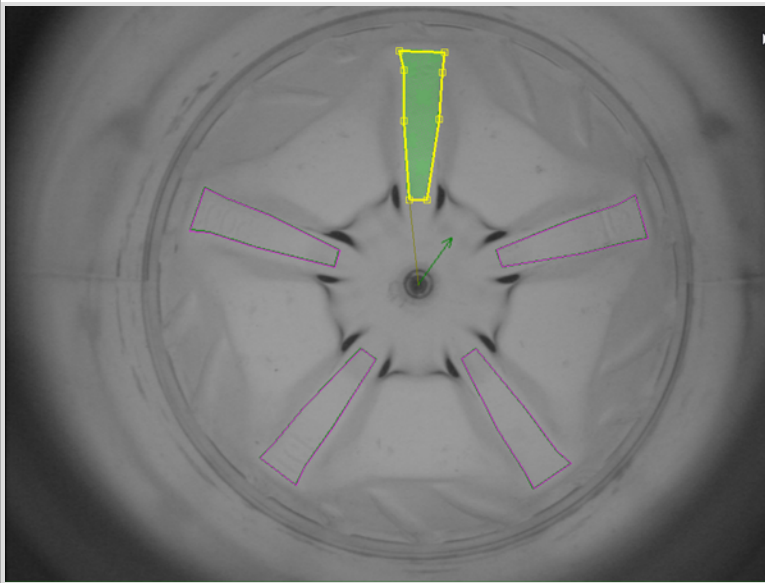

To set up the regions:

1. Click in the image to place points to create a polygon to cover the areas between the feet, as shown. (It does not matter which point you place first, nor how many points you use)
2. Click again over the first point. This will close the polygon.
3. The system automatically repeats the region around the base.
4. If you find that some regions are overlapping dark areas, then try making the region smaller.
5. Select the OK button to save changes and exit.

Set up the Between Foot Inspection

We are using a Contrast inspection to find defects between the feet.

The screenshot shows the 'Between Foot Inspection' settings panel. The 'Between Foot ROI' is selected. The settings are as follows:

Setting	Value
Contrast Limits	30.0
Size Filter	1 @ .. 512 @
Acceptable Size	0 @
Sizing	Total Width
Region Extraction	Read Radially
Advanced Settings	
Sample Filter	Integration Sampling
Fuzzy Edge Removal	Disabled
Defect Type	Light and Dark Defects
Optimize Settings	Optimize
Detection Mode	Defect Detect
Segment Settings	
Number of Rings	1
Segment Count	1

Double-click Between Foot Inspection in the inspection tree.

To set up the inspection:

1. For the most part, you can leave the parameters at the default values. Your values may vary, based on your part and system setup.
2.  Select the OK button to save changes and exit.

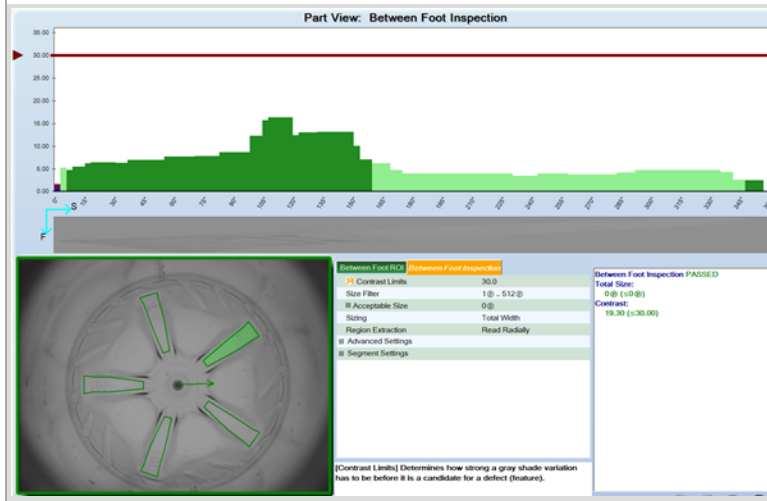

Between Foot inspection example

Place the Pearling ROI

We will set up the Region of Interest (ROI) to position the inspection on the base where pearling typically occurs.

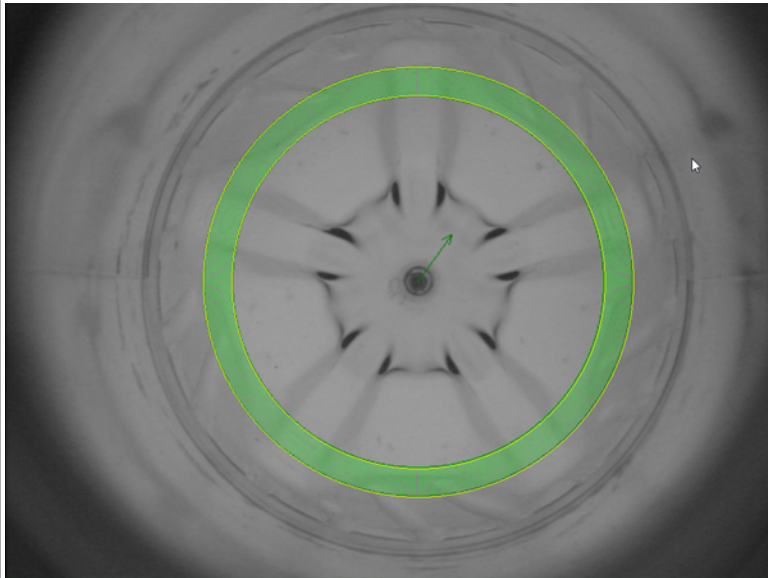

Double-click Pearling ROI in the inspection tree to edit.

To edit the region:

1. Click inside the two circles of the default region.
2. Place the region on the base as shown.
3. Leave the remaining parameters at the default values. Your values may vary, based on your part and system setup.

Pearling ROI	
X	0
Y	0
Inner Radius	155
Thickness	24
Use Arc Segments	<input type="checkbox"/> Enabled
Perimeter Type	Normal

4.  Select the OK button to save changes and exit.

Set up the Pearling Inspection

We are using a Contrast inspection to find pearling on the base.

Pearling ROI <i>Pearling Inspection</i>	
Contrast Limits	11.98
Size Filter	80@ .. 128@
<input type="checkbox"/> Acceptable Size	160@
Use Size Weighting	<input type="checkbox"/> Enabled
Sizing	Total Width
Region Extraction	Read Radially
<input type="checkbox"/> Advanced Settings	
Sample Filter	Integration Sampling
Fuzzy Edge Removal	Level 1
Defect Type	Dark Defects
Optimize Settings	
Detection Mode	Defect Detect
<input type="checkbox"/> Segment Settings	
Number of Rings	1
Segment Count	1

Double-click the Pearling Inspection to edit it.

To set up the inspection:

1. Pay attention to the parameters (outlined in red) shown to the left. Start with these settings, and adjust if needed for your part.
2. Leave the remaining parameters at the default values. Your values may vary, based on your part and system setup.
3. Select the OK button to save changes and exit.

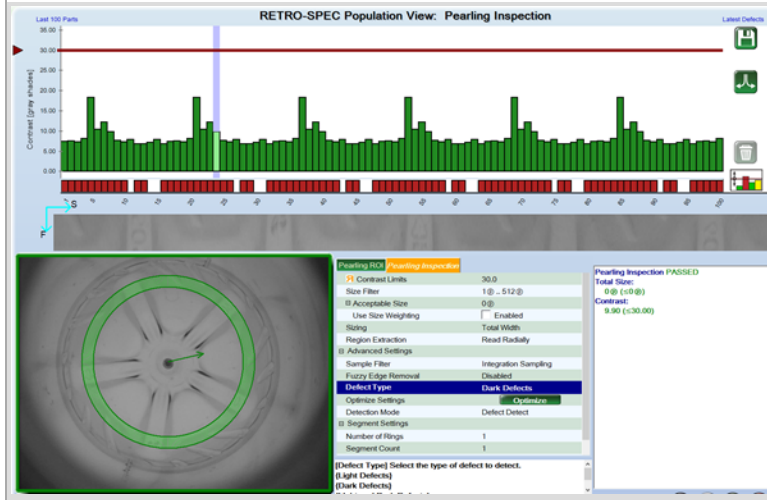

Pearling inspection example

Place the Gate Registration ROI

We will set up the Region of Interest (ROI) to position the inspection on the gate area.

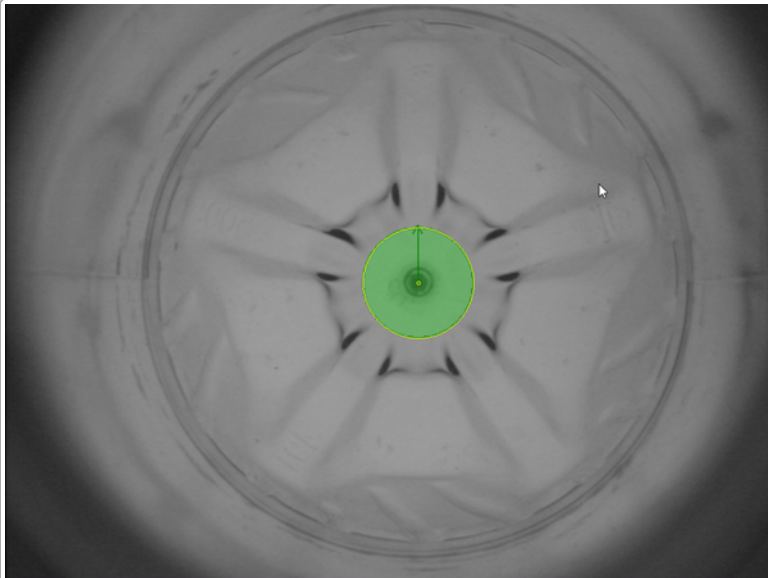

Double-click Gate Registration ROI in the inspection tree to edit.

To edit the region:

1. Place the region on the gate area as shown.
2. Leave the remaining parameters at the default values. Your values may vary, based on your part and system setup.

<i>Gate Registration ROI</i>	
X Offset	0
Y Offset	0
Inner Radius	1
Thickness	45
Perimeter Type	Normal

3.  Select the OK button to save changes and exit.

Set up the Gate Registration

We are using a Feature Registration to find the gate. This registration looks for all the pixels within a specified gray shade range, or a cluster of pixels.

Gate Registration ROI	
Region Extraction	Read Horizontally
Pixel Selection	Clustered Pixels
Center Detection	Largest Cluster
Pixel Gray Range	0 .. 105
Cluster Size	5 .. 10000
Show Clusters	<input checked="" type="checkbox"/> Enabled
Show Pixels	<input checked="" type="checkbox"/> Enabled
Show Cluster Centers	<input checked="" type="checkbox"/> Enabled
<input type="checkbox"/> Check Feature Area	
<input type="checkbox"/> Check Cluster Count	

Double-click Gate Registration to edit it.

To set up the registration:

Pay attention to the parameters (outlined in red) shown to the left. Start with these settings, and adjust if needed for your part.

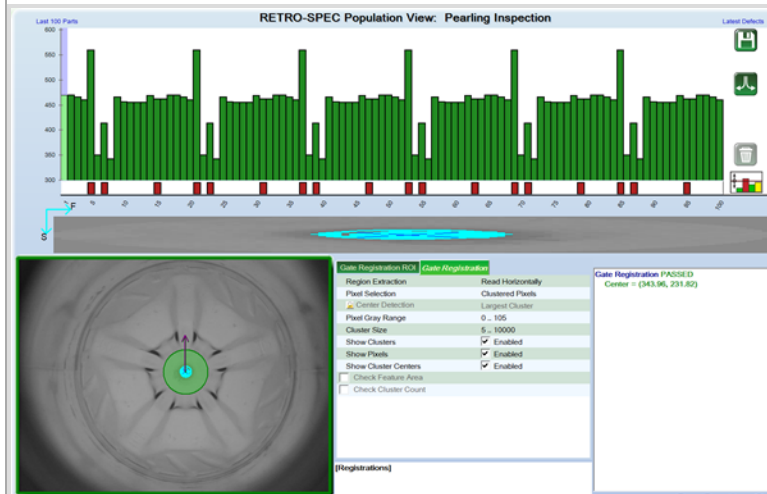

The system should now find the gate on your part.

Leave the remaining parameters at the default values. Your values may vary, based on your part and system setup.

Select the OK button to save changes and exit.

Place the Gate ROI

We will set up the Region of Interest (ROI) to position the inspection on the gate.

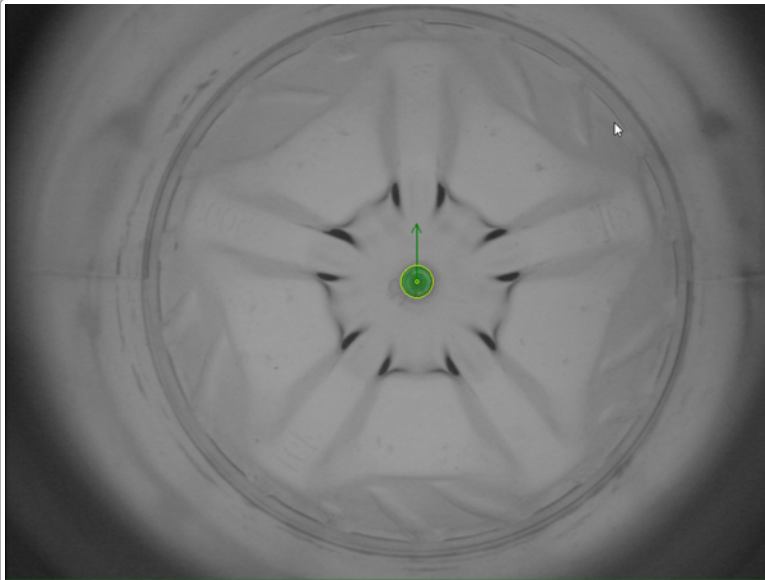

Double-click Gate ROI in the inspection tree to edit.

To edit the region:

1. Place the region on the gate as shown.
2. Leave the remaining parameters at the default values. Your values may vary, based on your part and system setup.

Gate ROI	
X	0
Y	0
Inner Radius	1
Thickness	12
Use Arc Segments	<input type="checkbox"/> Enabled
Perimeter Type	Normal

3.  Select the OK button to save changes and exit.

Set up the Gate Inspection

We are using a Contrast inspection to find defects on the gate.

Gate ROI	Gate Inspection	
<input checked="" type="checkbox"/>	Contrast Limits	30.0
	Size Filter	1 @ .. 512 @
<input type="checkbox"/>	Acceptable Size	0 @
	Use Size Weighting	<input type="checkbox"/> Enabled
	Sizing	Total Width
	Region Extraction	Read Radially
<input type="checkbox"/>	Advanced Settings	
	Sample Filter	Integration Sampling
	Fuzzy Edge Removal	Disabled
	Defect Type	Light and Dark Defects
	Optimize Settings	<input type="button" value="Optimize"/>
	Detection Mode	Defect Detect
<input type="checkbox"/>	Segment Settings	
	Number of Rings	5
	Segment Count	1

Double-click Gate Inspection to edit it.

To set up the inspection:

1. Pay attention to the parameters (outlined in red) shown to the left. Start with these settings, and adjust if needed for your part.
2. Leave the remaining parameters at the default values. Your values may vary, based on your part and system setup.
3. Select the OK button to save changes and exit.

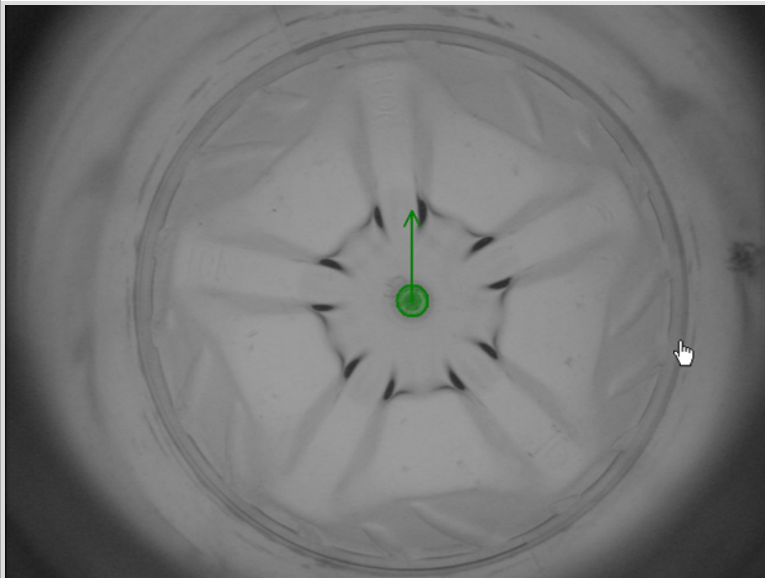

Gate inspection example

Place the Around Gate ROI

We will set up the Region of Interest (ROI) to position the inspection around the gate.

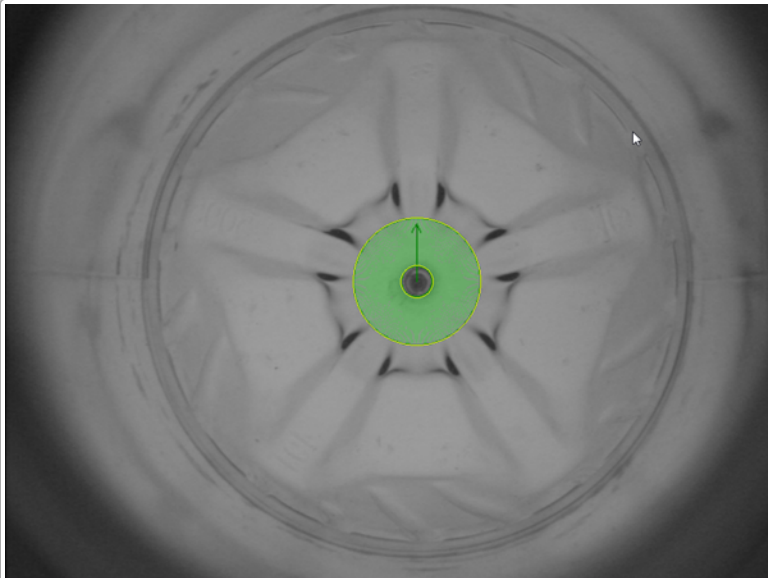

Double-click Around Gate ROI in the inspection tree to edit.

To edit the region:

1. Place the region around the gate as shown.
2. Leave the remaining parameters at the default values. Your values may vary, based on your part and system setup.

Around Gate ROI	
X	0
Y	0
Inner Radius	13
Thickness	40
Use Arc Segments	<input type="checkbox"/> Enabled
Perimeter Type	Normal

3. Select the OK button to save changes and exit.

Set up the Around Gate Inspection

We are using a Contrast inspection to find defects around the gate.

Around Gate ROI	Around Gate Inspection
<input checked="" type="checkbox"/> Contrast Limits	30.0
Size Filter	1 @ .. 512 @
<input type="checkbox"/> Acceptable Size	0 @
Use Size Weighting	<input type="checkbox"/> Enabled
Sizing	Total Width
Region Extraction	Read Radially
<input type="checkbox"/> Advanced Settings	
Sample Filter	Integration Sampling
Fuzzy Edge Removal	Disabled
Defect Type	Light and Dark Defects
Optimize Settings	<input checked="" type="checkbox"/> Optimize
Detection Mode	Defect Detect
<input type="checkbox"/> Segment Settings	
Number of Rings	5
Segment Count	1

Double-click Around Gate Inspection to edit.

To set up the inspection:

1. Pay attention to the parameters (outlined in red) shown to the left. Start with these settings, and adjust if needed for your part.
2. Leave the remaining parameters at the default values. Your values may vary, based on your part and system setup.
3. Select the OK button to save changes and exit.

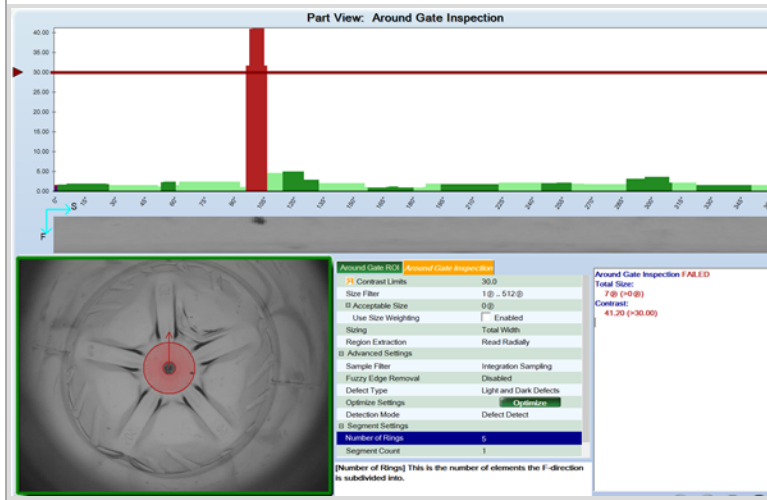

Around Gate inspection example

Place the Base Fold ROI

We will set up the Region of Interest (ROI) to position the inspection where base folds typically occur.

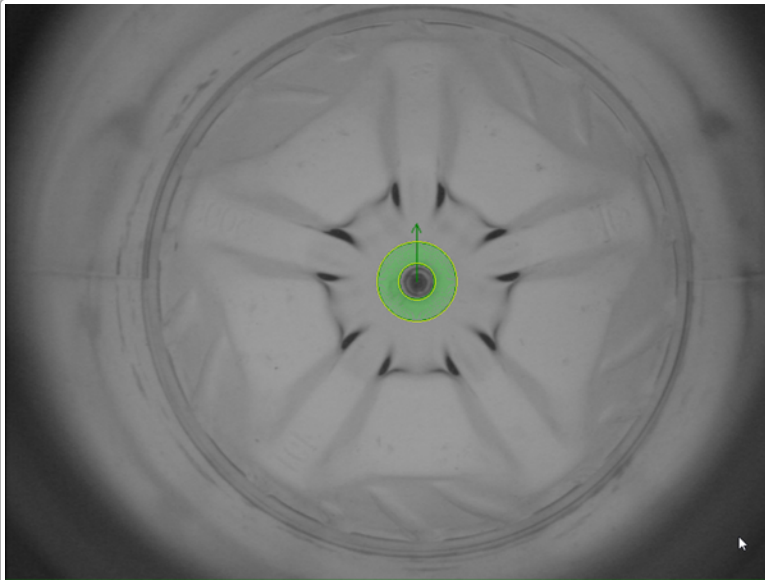

Double-click Base Fold ROI in the inspection tree to edit.

To edit the region:

1. Place the region around the gate as shown.
2. Leave the remaining parameters at the default values. Your values may vary, based on your part and system setup.

Base Fold ROI	
X	0
Y	0
Inner Radius	15
Thickness	18
Use Arc Segments	<input type="checkbox"/> Enabled
Perimeter Type	Normal

3.  Select the OK button to save changes and exit.

Set up the Base Fold Inspection

We are using an Ambient inspection to find base folds.

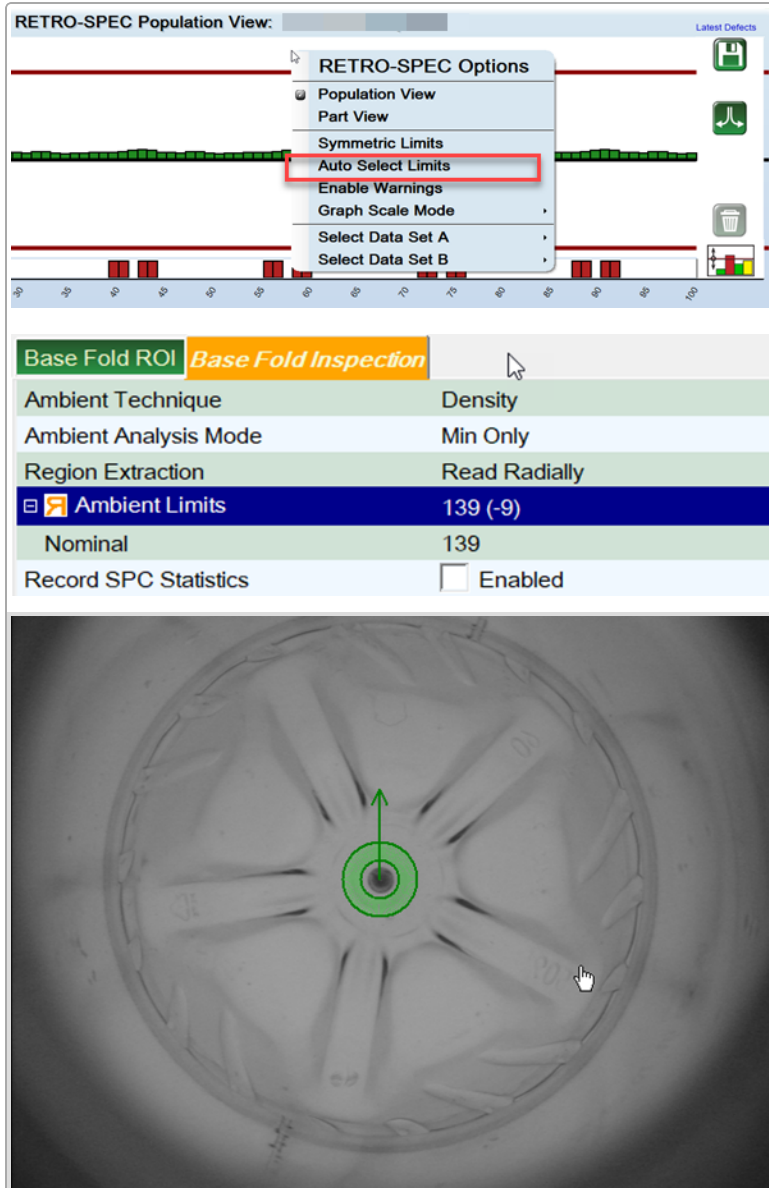

The screenshot shows the RETRO-SPEC software interface. At the top, there is a 'RETRO-SPEC Population View' graph with a context menu open, highlighting 'Auto Select Limits'. Below the graph is a configuration panel for 'Base Fold ROI' and 'Base Fold Inspection'. The panel includes the following settings:

Ambient Technique	Density
Ambient Analysis Mode	Min Only
Region Extraction	Read Radially
<input checked="" type="checkbox"/> Ambient Limits	139 (-9)
Nominal	139
Record SPC Statistics	<input type="checkbox"/> Enabled

At the bottom of the screenshot is a camera view of a wheel with a green ROI (Region of Interest) centered on the hub, indicated by a green circle and an upward-pointing arrow.

Double-click Base Fold Inspection to edit.

To set up the inspection:

1.  Put the lane online to acquire several images, and select the [+100] button.
2. Take the lane offline.
3. Right-click over the Retro-Spec Population View graph and choose Auto-Select Limits. The system will automatically set the inspection limits based on your parts.
4. Leave the remaining parameters at the default values. Your values may vary, based on your part and system setup.

To test the inspection:

1. Scroll through the images to make sure parts are passing (or failing) as expected.
2. You can make the inspection more sensitive by moving the red horizontal bars on the Retro-Spec graph closer to center, or less sensitive by moving the red horizontal bars away from center.

Base Fold inspection example

1.  Select the OK button to save changes and exit.

Set up the Off-Center Gate Inspection

We are using a Distance Measurement to detect off-center gates.

Off-Center Gate Inspection	Point 1	Point 2	Calibration
Source Type	Inspection		
Select Extraction 1	Select Inspection		
Assigned Inspection	True Center		
Location Provider Type	Registration		

Off-Center Gate Inspection	Point 1	Point 2	Calibration
Source Type	Inspection		
Select Extraction 2	Select Inspection		
Assigned Inspection	Gate Registration		
Location Provider Type	Registration		

Off-Center Gate Inspection	Point 1	Point 2	Calibration	
Distance Component	Point to Point			
Distance Limits	2.3839 @ +5.2131 @/ -2.3...			
Nominal	2.3839 @			
Record SPC Statistics	<input type="checkbox"/> Enabled			

Double-click Off-Center Gate Inspection to edit.

To set up the inspection:

1. Go to the Point 1 menu and click the Select Inspection button.
2. Select True Center from the inspection tree. Click the Apply Reference button to complete the selection.
3. Go to the Point 2 menu and click the Select Inspection button.
4. Select Gate Registration from the inspection tree. Click the Apply Reference button to complete the selection.
5. Right-click over the Retro-Spec Population View graph and choose Auto-Select Limits. The system will automatically set the inspection limits based on your part.
6. Leave the remaining parameters at the default values. Your values may vary, based on your part and system setup.
7. Select the OK button to save changes and exit.

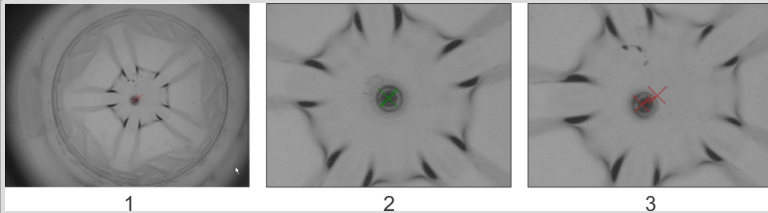

- 1) Full image with swung gate
- 2) Enlarged image of good part,
- 3) Enlarged image of bad part showing incorrect position of gate

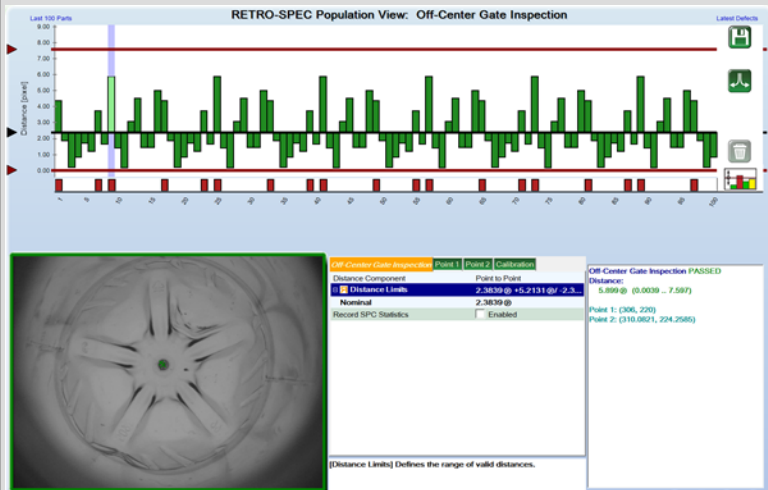

To test the inspection:

1. Scroll through the images to make sure parts are passing (or failing) as expected.
2. You can make the inspection more sensitive by moving the red horizontal bars on the Retro-Spec graph closer to center, or less sensitive by moving the red horizontal bars away from center.

An example of off-center gate inspection is shown to the left

Module 11 Inspections for Neck Camera

This section explains how to set up the inspections. Note that your inspections may be different, depending on your specific part, plant, and process requirements.

The picture below shows an image with all neck inspection regions. We will set these up one at a time.

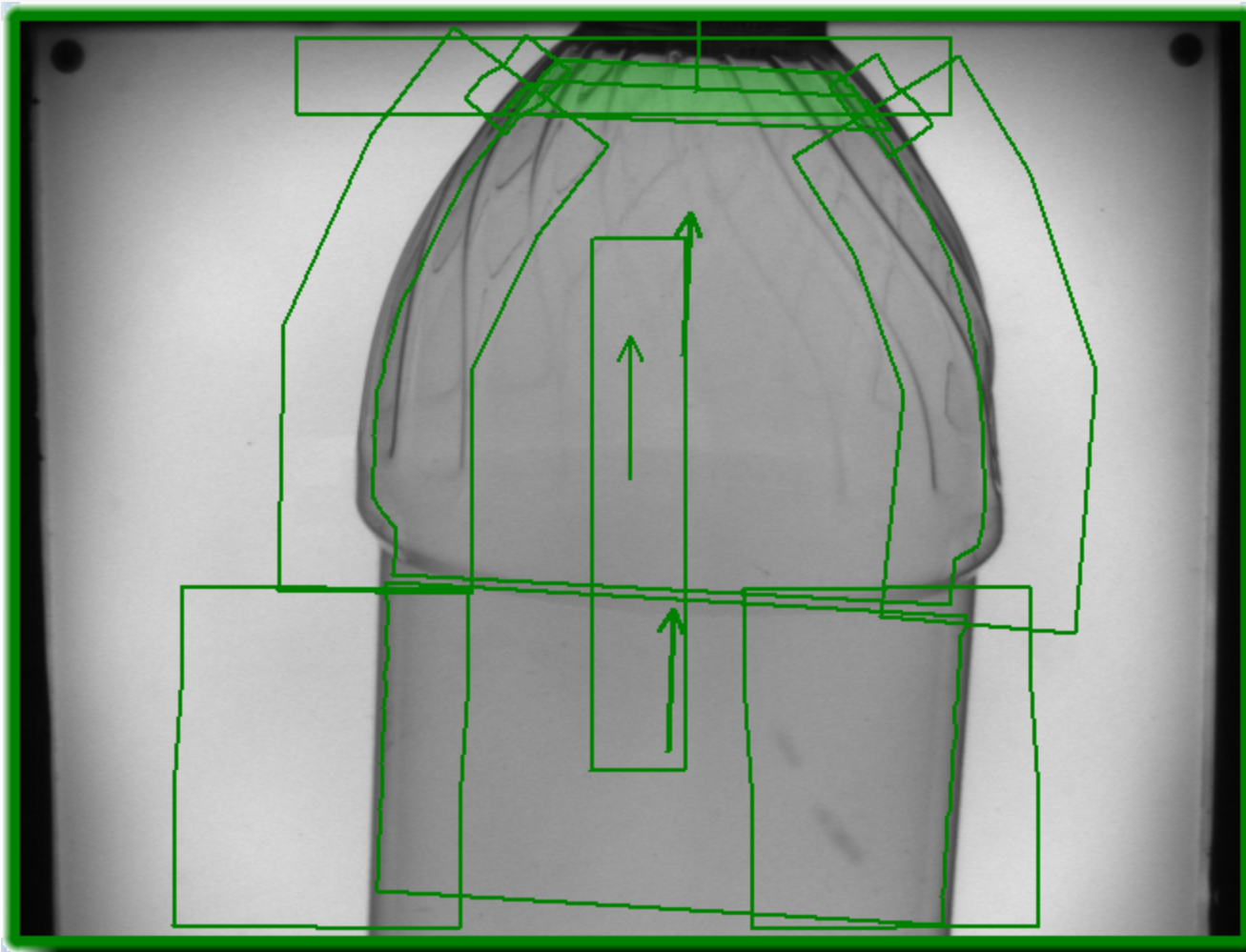

Create the Neck Inspection Tree

The steps below will guide you through the process of building the Neck Inspection Tree, while ensuring that the directory links are connected correctly. First add the inspections, then rename them to something that makes sense to you. Note that we will set up the regions and parameters later. For now, we will just build the inspection tree.

Note for all steps: when you add the inspection, you can rename it immediately.

After each step, select the OK button to save changes, and the Exit button to exit the inspection.

This is how the inspection tree will look

Steps to add the inspections

Note: ROI = Region of Interest

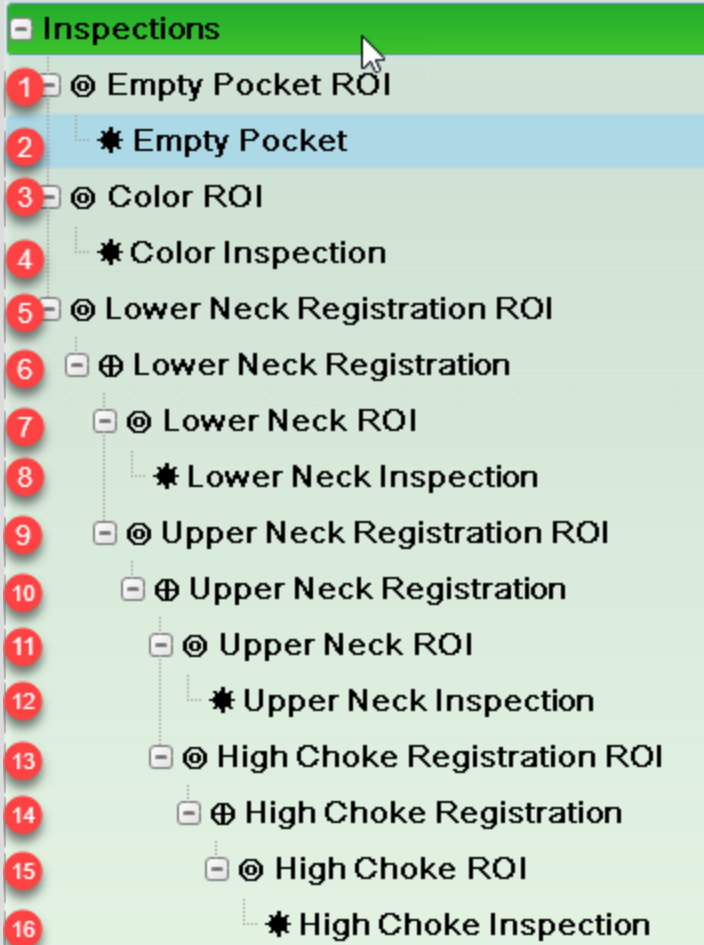

Inspection tree- repeated

1. **Inspections** Right-click Inspections. Add | Region | Ribbon. Rename it Empty Pocket ROI.
2. Right-click Empty Pocket ROI. Add | Analysis | Contrast. Rename it Empty Pocket.
3. **Inspections** Right-click Inspections. Add | Region | Ribbon. Rename it Color ROI.
4. Right-click Color ROI. Add | Analysis | Ambient. Rename it Color Inspection.
5. **Inspections** Right-click Inspections. Add | Region | Ribbon. Rename it Lower Neck Registration ROI.
6. Right-click Lower Neck Registration ROI. Add | Registration | Centerline. Rename it Lower Neck Registration.
7. Right-click Lower Neck Registration. Add | Region | Adaptive. Rename it Lower Neck ROI.
8. Right-click Lower Neck ROI. Add | Analysis | Contrast. Rename it Lower Neck Inspection.
9. Right-click Lower Neck Registration. Add | Region | Ribbon. Rename it Upper Neck Registration ROI.
10. Right-click Upper Neck Registration ROI. Add | Registration | Centerline. Rename it Upper Neck Registration.
11. Right-click Upper Neck Registration. Add | Region | Adaptive. Rename it Upper Neck ROI.
12. Right-click Upper Neck ROI. Add | Analysis | Contrast. Rename it Upper Neck Inspection.
13. Right-click Upper Neck Registration. Add | Region | Ribbon. Rename it High Choke Registration ROI.
14. Right-click High Choke Registration ROI. Add | Registration | Centerline. Rename it High Choke Registration.
15. Right-click High Choke Registration. Add | Region | Adaptive. Rename it High Choke ROI.
16. Right-click High Choke ROI. Add | Analysis | Contrast. Rename it High

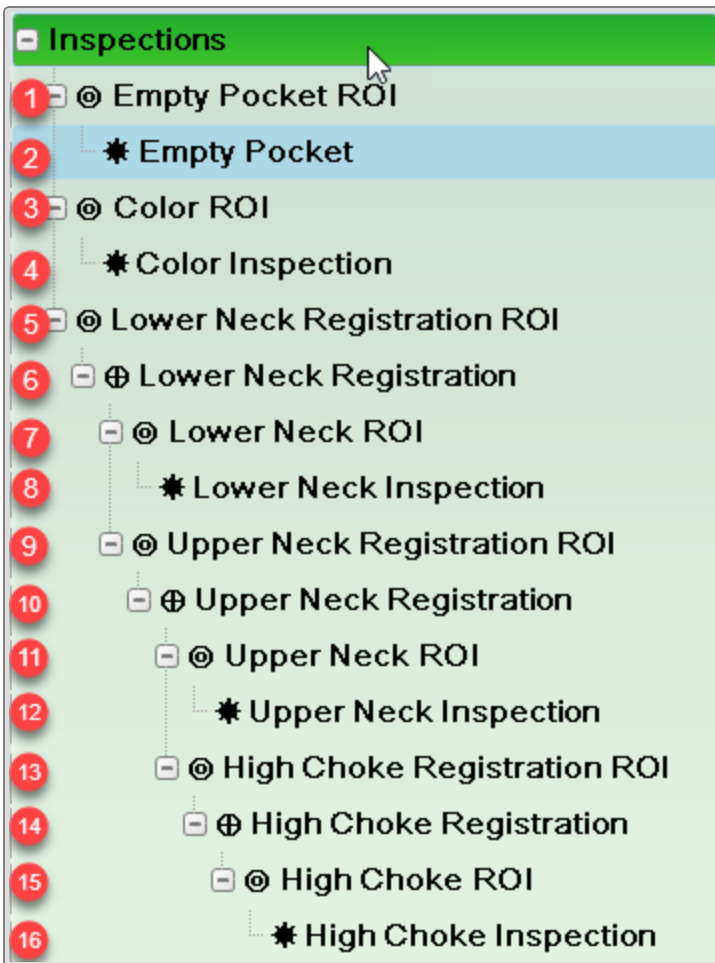

Choke Inspection.

Your inspection tree should look similar to that shown on the left.

Place the Empty Pocket ROI

An empty pocket inspection must be applied if your system is using a PDX. The Empty Pocket is used to determine if the bottle is in the gripper fingers. If so it allows the inspections to be performed; if not, it stops the inspections from being done.

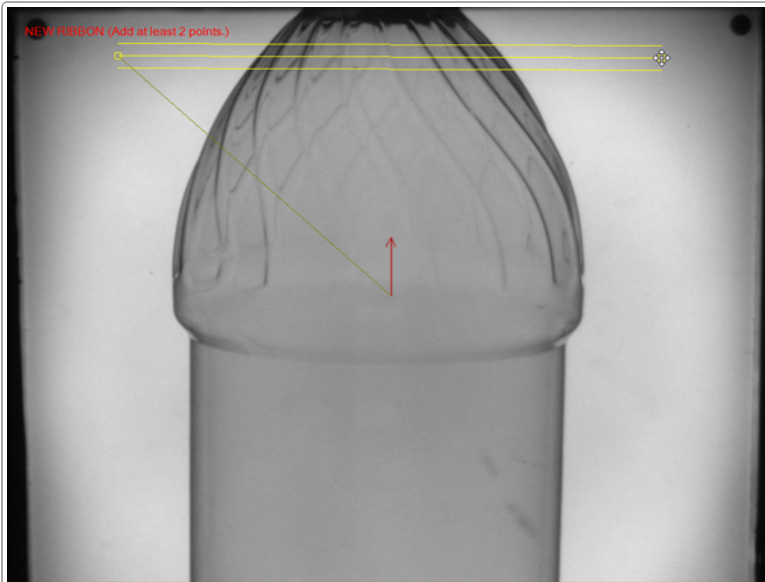

Double-click Empty Pocket ROI in the inspection tree.

If the Ribbon is not already set on the image: it says NEW RIBBON (Click to add points). Click in the image to place two points to create a line as shown.

Then right-click over the image and select Complete New Ribbon. A ribbon with yellow lines will be displayed on the image.

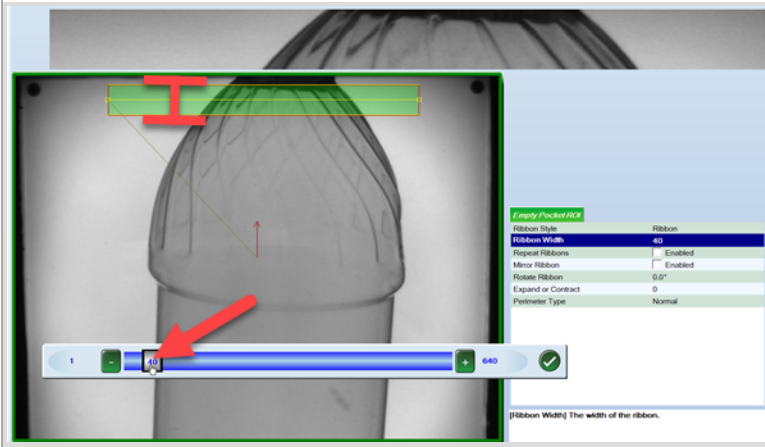

We want the ribbon to locate the top of the bottle in each image.

To make the ribbon wider:

1. Select Ribbon Width and make it wider. In our example, we used 40 for Ribbon Width.
2. Leave the remaining parameters at the default values. Your values may vary, based on your part and system setup.
3.  Select the OK button to save changes and exit.

Set up the Neck Empty Pocket Inspection

We will set up this inspection to detect some dark pixels over the top neck area. If these dark pixels do not appear, then the system will know that there is no bottle present, and therefore not run any further inspections.

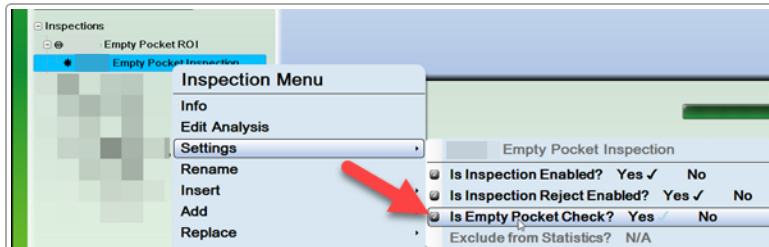

In the Inspection Tree, right-click over the Empty Pocket Inspection. Select Settings | Is Empty Pocket Check? Click to enable it.

The system will give a warning that rejecting is off. This is OK.

The name of the Empty Pocket inspection will have a blue background in the inspection tree.

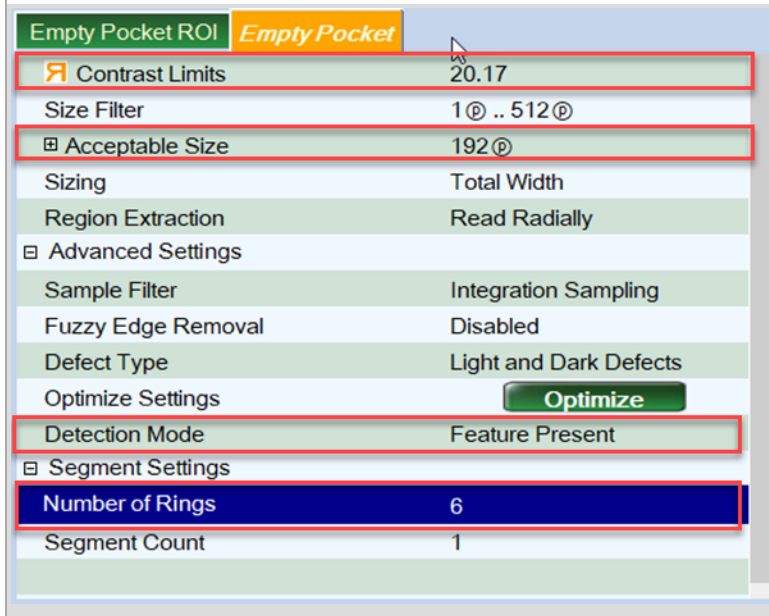

Double-click Empty Pocket (in the inspection tree) to edit it.

If you need to see images, put the lane online to acquire several images. Take the lane offline, and select the [+100] button below the image.

To set the parameters:

1. Pay attention to the parameters (outlined in red) shown to the left. Start with these settings, and adjust if needed for your part.
2. Leave the remaining parameters at the default values. Your values may vary, based on your part and system setup.

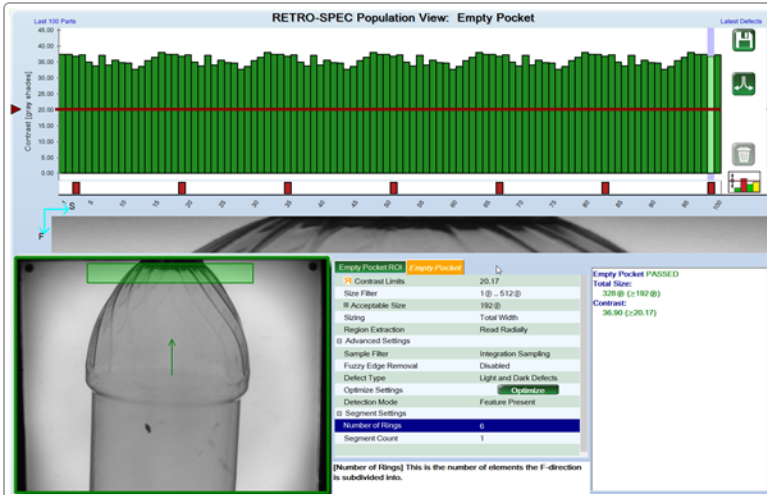

Images with parts in the field of view should pass the inspection. If a part was missing, it would fail.



Select the OK button to save changes and exit.

Place the Color ROI

We are using a ribbon for the small region to check if the bottle is the correct color.

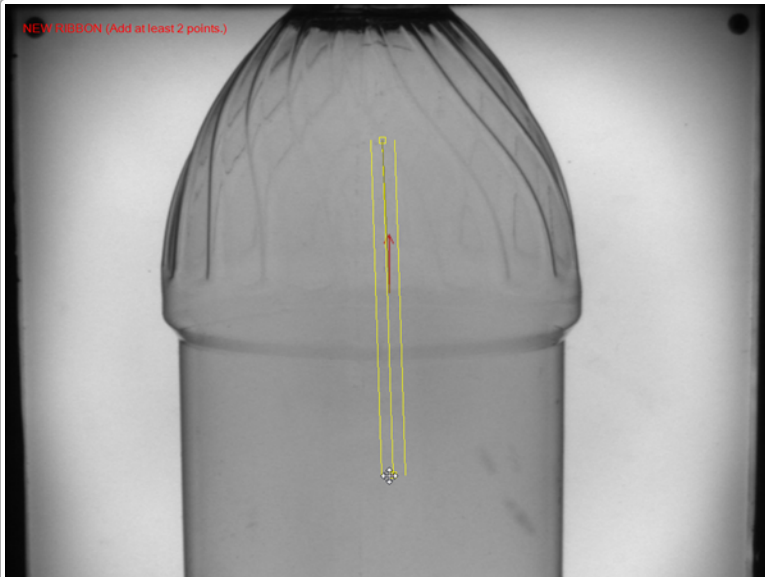

Double-click Color ROI in the inspection tree.

If the Ribbon is not already set on the image: it says NEW RIBBON (Click to add points). Click in the image to place two points to create a line as shown.

Then right-click over the image and select Complete New Ribbon. A ribbon with yellow lines will be displayed on the image.

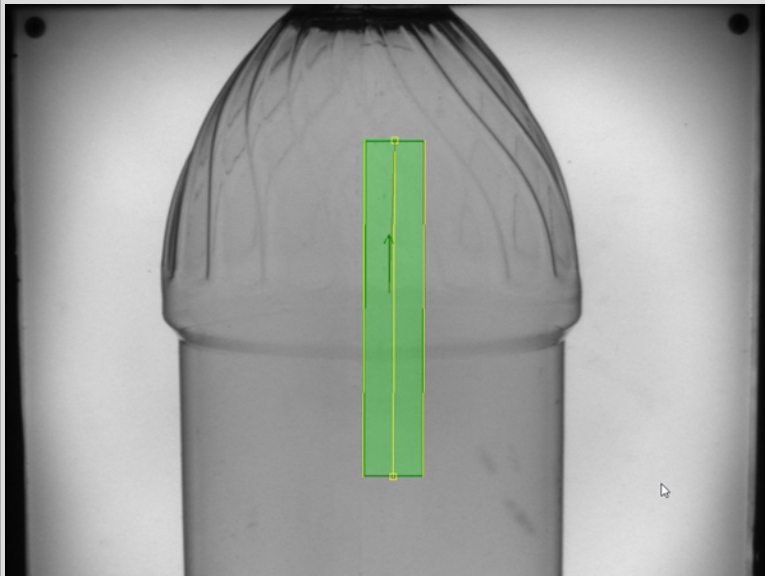

We want the ribbon wide enough to determine the gray shade of the bottle.

To make the ribbon wider:

1. Select Ribbon Width and make it wider. In our example, we used 50 for Ribbon Width.
2. Leave the remaining parameters at the default values. Your values may vary, based on your part and system setup.
3. Select the OK button to save changes and exit.

Color ROI	
Ribbon Style	Ribbon
Ribbon Width	50
Repeat Ribbons	<input type="checkbox"/> Enabled
Mirror Ribbon	<input type="checkbox"/> Enabled
Rotate Ribbon	0.0°
Expand or Contract	0
Perimeter Type	Normal

Set up the Color Inspection

We are using an Ambient inspection to verify the correct color bottles.

RETRO-SPEC Options

- Population View
- Part View
- Symmetric Limits
- Auto Select Limits**
- Enable Warnings
- Graph Scale Mode
- Select Data Set A
- Select Data Set B

Color ROI	Color Inspection
Ambient Technique	Density
Ambient Analysis Mode	Min & Max
Region Extraction	Read Radially
<input checked="" type="checkbox"/> Ambient Limits	150 +6/ -6
Nominal	150
Record SPC Statistics	<input type="checkbox"/> Enabled

RETRO-SPEC Population View: Color Inspection

Ambient Value (in gray analysis)

Color Inspection PASSED
Ambient Value: 153
[149, [147, 155], 157]
Lower Limit = 145 = 151 - 6
Upper Limit = 157 = 151 + 6

Nominal: 151
Record SPC Statistics: Enabled

[Ambient Limits] Sets the range for the grayscale averaged over the region that will pass the inspection.

Double-click Color Inspection to edit it.

To set up the inspection:

1. Put the lane online to acquire several images, and select the [+100] button.
2. Take the lane offline.
3. Right-click over the Retro-Spec Population View graph and choose Auto-Select Limits. The system will automatically set the inspection limits based on your parts.
4. Leave the remaining parameters at the default values. Your values may vary, based on your part and system setup.

To test the inspection:

1. Scroll through the images to make sure parts are passing (or failing) as expected.
2. You can make the inspection more sensitive by moving the red horizontal bars on the Retro-Spec graph closer to center, or less sensitive by moving the red horizontal bars away from center.

Color inspection example

- Select the OK button to save changes and exit.

Place the Lower Neck Registration ROI

We are using a ribbon to locate the lower neck. This will ensure proper placement of inspections on the lower neck.

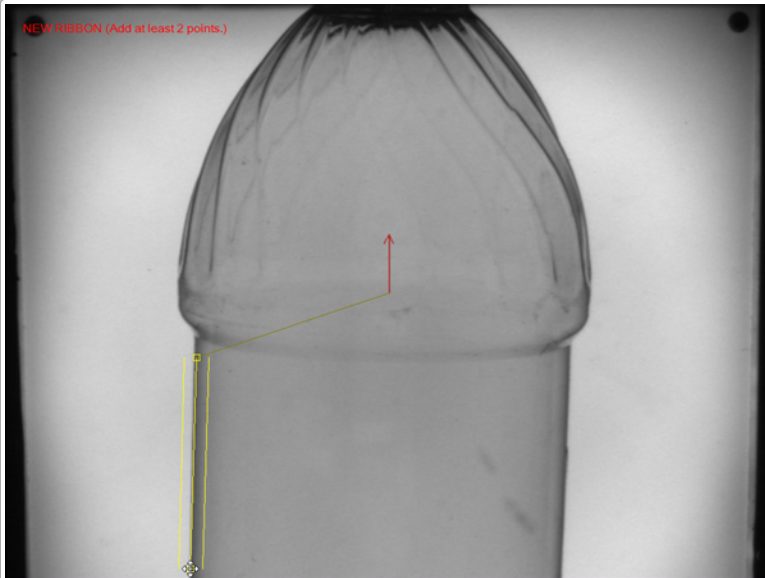

Double-click Lower Neck Registration ROI in the inspection tree.

If the Ribbon is not already set on the image: it says NEW RIBBON (Click to add points). Click in the image to place two points (on the side of the bottle) to create a line as shown.

Then right-click over the image and select Complete New Ribbon. A ribbon with yellow lines will be displayed on the image.

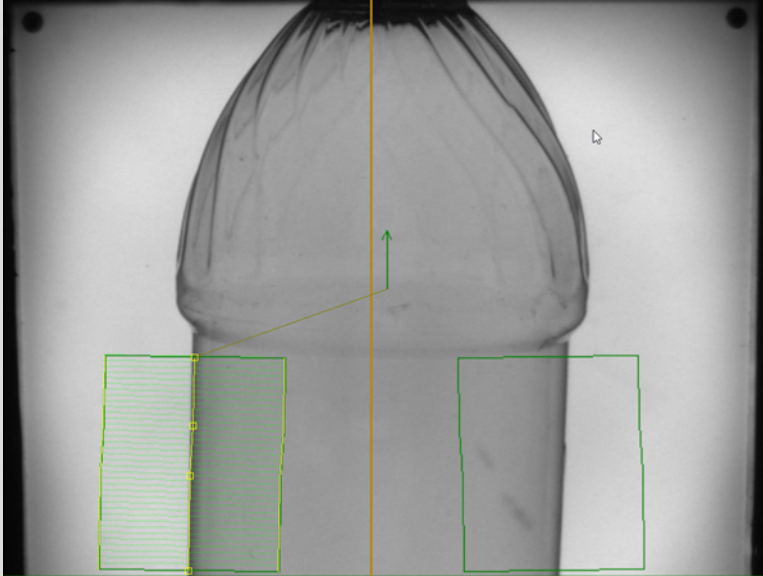

We want the ribbon to locate the sides of the bottle in each image.

To adjust the ribbon:

1. Select Ribbon Width and make it wider. In our example, we used 150 for Ribbon Width.
2. Check Mirror Ribbon. This creates another ribbon on the other side of the bottle.
3. Leave the remaining parameters at the default values. Your values may vary, based on your part and system setup.

Lower Neck Registration ROI	
Ribbon Style	Ribbon
Ribbon Width	150
Mirror Ribbon	<input checked="" type="checkbox"/> Enabled
Mirror Angle	0.0°
Mirror Offset	0
Rotate Ribbon	0.0°
Expand or Contract	0
Perimeter Type	Normal



Select the OK button to save changes and exit.

Set up the Lower Neck Registration

We are using a Centerline Registration to find the sides of the part. This allows the system to place the following inspections properly on the part.

Search Settings

Vector Direction	Outwards
Edge Polarity	Light-to-Dark
Edge Gradient	0 .. 43
Edge Delta	2
Edge Size	2
Use Subpixel	<input type="checkbox"/> Enabled

Lower Neck Registration

Applied Results	Center and Orientation
Setup Mode	Common Setup
Search Vector Count	36
Centerline Correction Iterations	0
Region Extraction	Read Radially
Diagnostics	
<input type="checkbox"/> Shape Check	
<input checked="" type="checkbox"/> Area Check	
<input checked="" type="checkbox"/> Area Range	54445 +2950/ -2950
Learn Nominal Area	Learn
<input type="checkbox"/> Angle Check	
<input type="checkbox"/> Enhance Center	

Double-click Lower Neck Registration in the inspection tree.

To set up the registration:

1. Go to the Search Settings tab. Pay attention to the parameters (outlined in red) shown to the left. Start with these settings, and adjust if needed for your part. This allows the system to find the edges of the bottle.
2. Go to the Lower Neck Registration menu.
3. Uncheck Shape Check.
4. Check Area Check. We are using an Area Check to make sure the system finds the correct points on the bottle.
5. Click the Learn button. The system will automatically determine the area we are searching for.



To test the inspection:

1. Scroll through several images to make sure the inspection is passing (or failing) as expected.
2. You can move the red horizontal bars towards the black line in the upper graph to make the inspection more sensitive (fail more bottles), or away from the black line to make it less sensitive (pass more bottles).

The system displays cyan [+] where it is finding the edges of the bottles.

-  Select the OK button to save changes and exit.

Place the Lower Neck ROI

We are using an Adaptive Region to position inspections on the lower neck.



Double-click Lower Neck ROI in the inspection tree.

To place the region:

1. Change Creation Mode to Fixed Region.
2. Click the Get Region button. The system will automatically create the region based on the points found in the Lower Neck Registration.
3. Set Edge Offset at approximately -10. This allows the system to ignore edges of the bottle.

The region should look similar to the example shown.

- Select the OK button to save changes and exit.

Set up the Lower Neck Inspection

We are using a Contrast inspection to find defects in the lower neck.

Lower Neck ROI	Lower Neck Inspection
Contrast Limits	23.9
Size Filter	1 @ .. 512 @
Acceptable Size	112 @
Sizing	Total Width
Region Extraction	Read Horizontally
Advanced Settings	
Sample Filter	Integration Sampling
Fuzzy Edge Removal	Disabled
Defect Type	Light and Dark Defects
Optimize Settings	Optimize
Detection Mode	Defect Detect
Segment Settings	
Segment Count	1
Ring Height	4

Double-click Lower Neck Inspection to edit it.

To set up the inspection:

1. Pay attention to the parameters (outlined in red) shown to the left. Start with these settings, and adjust if needed for your part.
2.  Select the OK button to save changes and exit.

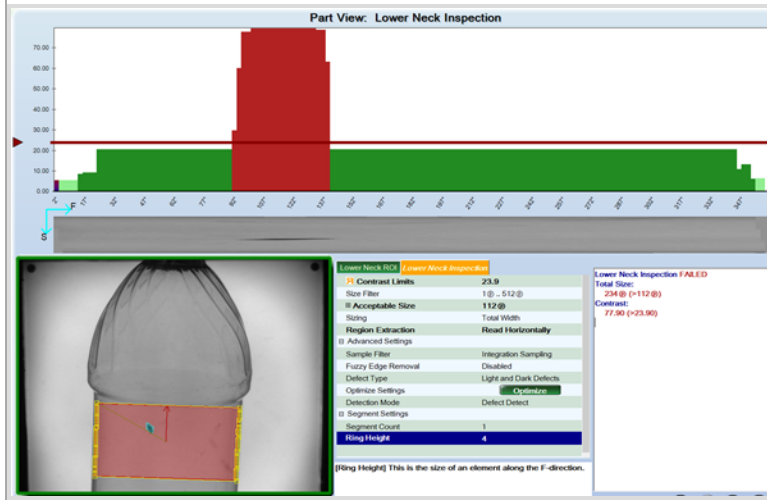

This example shows contamination found on the lower neck - Part View shown.

Place the Upper Neck Registration ROI

We are using a ribbon to allow the system to find the sides of the upper neck.

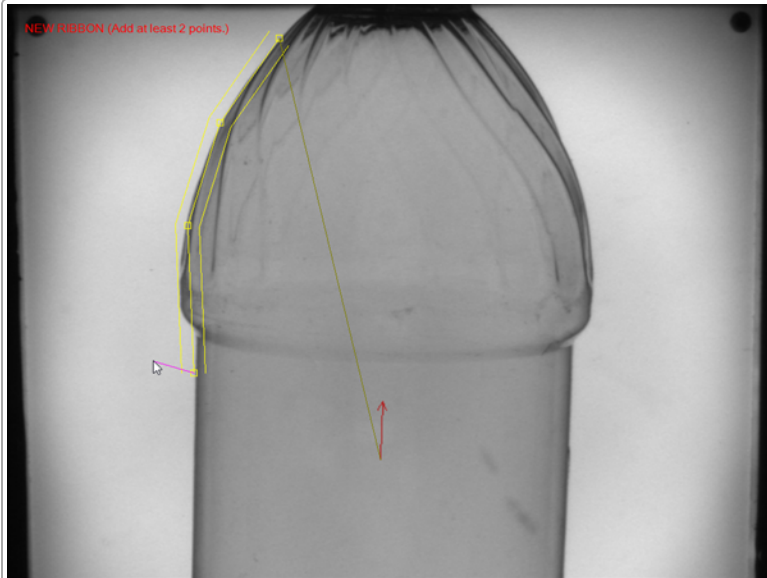

Double-click Upper Neck Registration ROI in the inspection tree.

If the Ribbon is not already set on the image: it says NEW RIBBON (Click to add points). Click in the image to place points (on the side of the upper neck) to create a line as shown. Place points according to the size and shape of your bottle.

Then right-click over the image and select Complete New Ribbon. A ribbon with yellow lines will be displayed on the image.

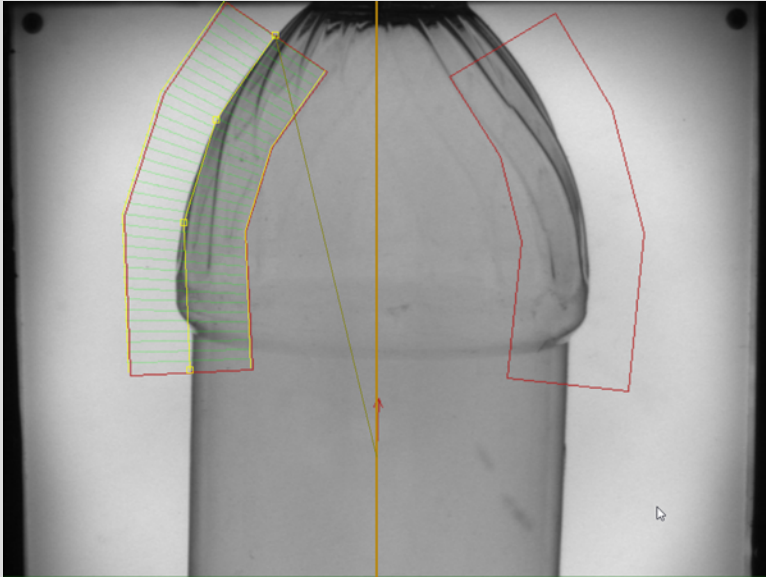

We want the ribbon to locate the sides of the bottle in each image.

To adjust the ribbon:

1. Select Ribbon Width and make it wider. In our example, we used 102 for Ribbon Width.
2. Check Mirror Ribbon. This creates another ribbon on the other side of the bottle.
3. Make sure the ribbon points do not touch the edge of the image. If they do, right-click over the image and select Enable Region Editor. Move the points downward if necessary.

Leave the remaining parameters at the default values. Your values may vary, based on your part and system setup.

Upper Neck Registration ROI	
Ribbon Style	Ribbon
Ribbon Width	102
Mirror Ribbon	<input checked="" type="checkbox"/> Enabled
Mirror Angle	0.0°
Mirror Offset	0
Rotate Ribbon	0.0°
Expand or Contract	0
Perimeter Type	Normal



Select the OK button to save changes and exit.

Set up the Upper Neck Registration

We are using a Centerline Registration to find the sides of the part. This allows the system to place the following inspections properly on the part.

Upper Neck Registration ROI Upper Neck Registration

Search Settings

Vector Direction	Outwards
Edge Polarity	Light-to-Dark
Edge Gradient	0 .. 43
Edge Delta	2
Edge Size	2
Use Subpixel	<input type="checkbox"/> Enabled

Search Settings

Upper Neck Registration ROI Upper Neck Registration

Applied Results	Center and Orientation
Setup Mode	Common Setup
Search Vector Count	36
Centerline Correction Iterations	0
Region Extraction	Read Radially

▣ Diagnostics

<input type="checkbox"/> Shape Check	
<input checked="" type="checkbox"/> Area Check	
<input checked="" type="checkbox"/> Area Range	83029 +5000/ -5000
Learn Nominal Area	<input type="button" value="Learn"/>
<input type="checkbox"/> Angle Check	
<input type="checkbox"/> Enhance Center	

Double-click Upper Neck Registration in the inspection tree.

To set up the registration:

1. Go to the Search Settings tab. Pay attention to the parameters (outlined in red) shown to the left. Start with these settings, and adjust if needed for your part. This allows the system to find the edges of the bottle.
2. Go to the Upper Neck Registration menu.
3. Uncheck Shape Check.
4. Check Area Check. We are using an Area Check to make sure the system finds the correct points on the bottle.
5. Click the Learn button. The system will automatically determine the area we are searching for.

Place the Upper Neck ROI

We are using an Adaptive Region to position inspections on the upper neck.



Double-click Upper Neck ROI in the inspection tree.

To place the region:

1. Change Creation Mode to Fixed Region.
2. Click the Get Region button. The system will automatically create the region based on the points found in the Upper Neck Registration.
3. Set Edge Offset at approximately -10. This allows the system to ignore edges of the bottle.

The region should look similar to the example shown.

- Select the OK button to save changes and exit.

Set up the Upper Neck Inspection

We are using a Contrast inspection to find defects in the upper neck.

The screenshot shows the 'Upper Neck Inspection' settings panel. The following parameters are highlighted with red boxes:

- Contrast Limits: 30.0
- Size Filter: 5 @ .. 48 @
- Acceptable Size: 128 @
- Ring Height: 20

Other visible settings include:

- Sizing: Total Width
- Region Extraction: Read Horizontally
- Advanced Settings: Sample Filter (Integration Sampling), Fuzzy Edge Removal (Disabled), Defect Type (Light and Dark Defects), Optimize Settings (Optimize button), Detection Mode (Defect Detect)
- Segment Settings: Segment Count (1)

This inspection is set up to ignore the geometry of the bottle and only find defects. Double-click Upper Neck Inspection to edit it.

To set up the inspection:

1. Pay attention to the parameters (outlined in red) shown to the left. Start with these settings, and adjust if needed for your part.
2.  Select the OK button to save changes and exit.

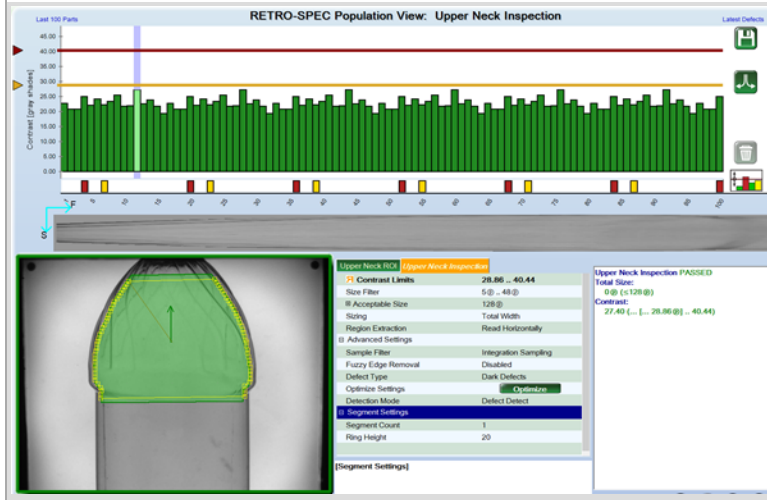

Upper Neck example

Place the High Choke Registration ROI

We are using a ribbon to allow the system to find the sides of the upper neck.



Double-click High Choke Registration ROI in the inspection tree.

If the Ribbon is not already set on the image: it says NEW RIBBON (Click to add points). Click in the image to place points to create a line as shown (near the top of the bottle). Place points according to the size and shape of your bottle.

Then right-click over the image and select Complete New Ribbon. A ribbon with yellow lines will be displayed on the image.

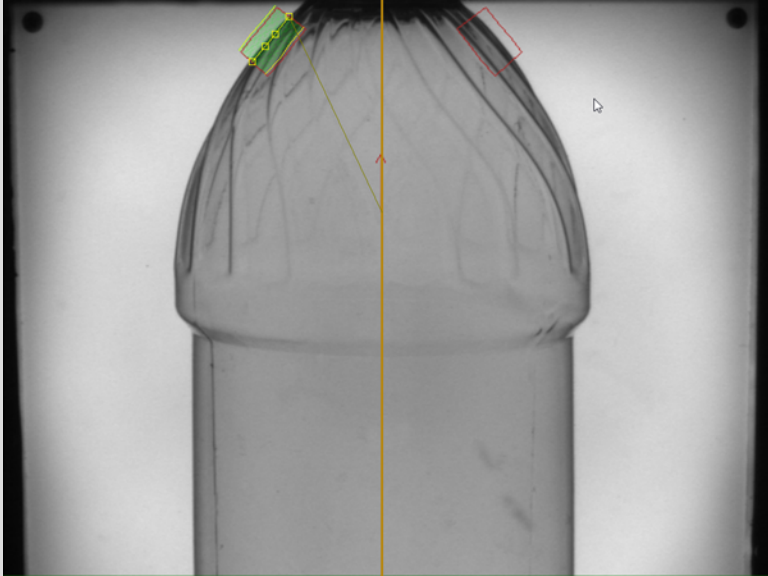

We want the ribbon to locate the sides of the bottle in each image.

To adjust the ribbon:

1. Select Ribbon Width and make it wider. In our example, we used 30 for Ribbon Width.
2. Check Mirror Ribbon. This creates another ribbon on the other side of the bottle.

Leave the remaining parameters at the default values. Your values may vary, based on your part and system setup.

High Choke Registration ROI	
Ribbon Style	Ribbon
Ribbon Width	30
Mirror Ribbon	<input checked="" type="checkbox"/> Enabled
Mirror Angle	0.0°
Mirror Offset	0
Rotate Ribbon	0.0°
Expand or Contract	0
Perimeter Type	Normal



Select the OK button to save changes and exit.

Set up the High Choke Registration

We are using a Centerline Registration to find the sides of the part. This allows the system to place the following inspections properly on the part.

High Choke Registration ROI High Choke Registration

Search Settings

Vector Direction	Outwards
Edge Polarity	Light-to-Dark
Edge Gradient	0 .. 50
Edge Delta	2
Edge Size	2
Use Subpixel	<input type="checkbox"/> Enabled

Search Settings

High Choke Registration ROI High Choke Registration

Applied Results	Center and Orientation
Setup Mode	Common Setup
Search Vector Count	36
Centerline Correction Iterations	0
Region Extraction	Read Radially

▣ Diagnostics

<input type="checkbox"/> Shape Check	
<input checked="" type="checkbox"/> Area Check	
▣ <input checked="" type="checkbox"/> Area Range	6813 +/-422
Nominal	6813
Learn Nominal Area	Learn
<input type="checkbox"/> Angle Check	
<input type="checkbox"/> Enhance Center	

Double-click High Choke Registration in the inspection tree.

To set up the registration:

1. Go to the Search Settings tab. Pay attention to the parameters (outlined in red) shown to the left. Start with these settings, and adjust if needed for your part. This allows the system to find the edges of the bottle.
2. Go to the High Choke Registration menu.
3. Uncheck Shape Check.
4. Check Area Check. We are using an Area Check to make sure the system finds the correct points on the bottle.
5. Click the Learn button. The system will automatically determine the area we are searching for.

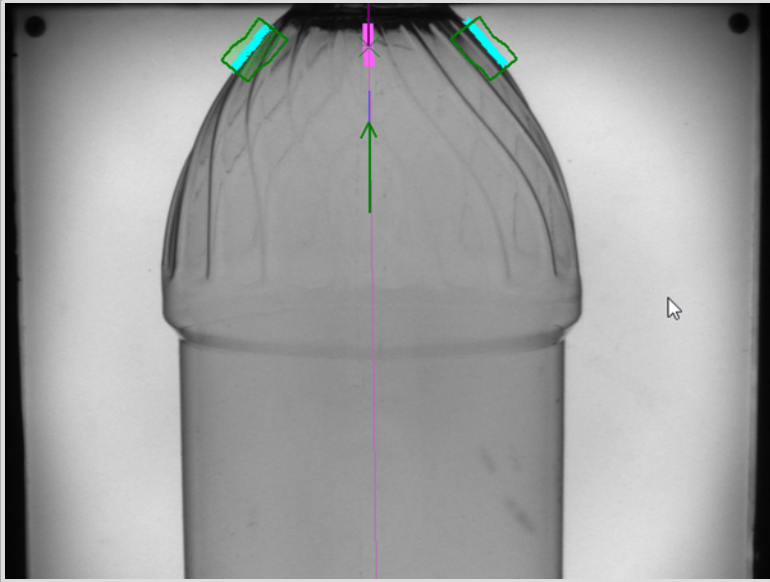

Scroll through several images to verify that the system is finding edges consistently on all bottles. Make adjustments if necessary.

Select the OK button to save changes and exit.

Place the High Choke ROI

We are using an Adaptive Region to position inspections to detect high chokes.

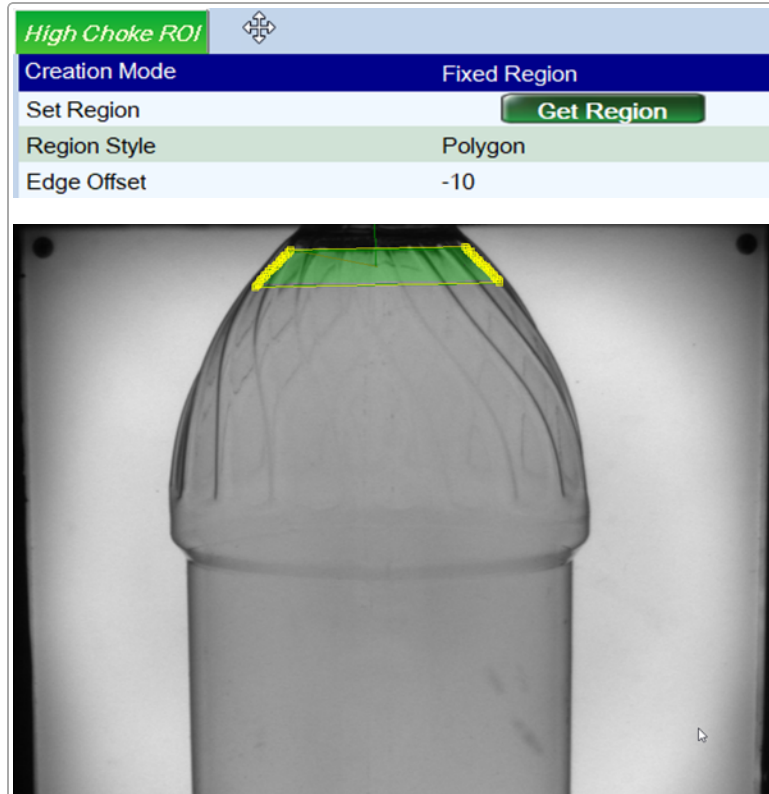

Double-click High Choke ROI in the inspection tree.

To place the region:

1. Change Creation Mode to Fixed Region.
2. Click the Get Region button. The system will automatically create the region based on the points found in the High Choke Registration.
3. Set Edge Offset at approximately -10. This allows the system to ignore edges of the bottle.

The region should look similar to the example shown.

- Select the OK button to save changes and exit.

Set up the High Choke Inspection

We are using a Contrast inspection to detect high choke.

Section	Value
High Choke ROI	High Choke Inspection
Contrast Limits	40.0
Size Filter	1 @ .. 512 @
Acceptable Size	0 @
Sizing	Total Width
Region Extraction	Read Horizontally
Advanced Settings	
Sample Filter	Integration Sampling
Fuzzy Edge Removal	Disabled
Defect Type	Dark Defects
Optimize Settings	Optimize
Detection Mode	Defect Detect
Segment Settings	
Segment Count	1
Ring Height	56

This inspection is set up to ignore the geometry of the bottle and only find defects. Double-click the High Choke Inspection to edit it.

To set up the inspection:

1. Pay attention to the parameters (outlined in red) shown to the left. Start with these settings, and adjust if needed for your part.
2.  Select the OK button to save changes and exit.

RETRO-SPEC Population View: High Choke Inspection

Contrast (gray shades)

High Choke Inspection PASSED

Total Size: 939 (100%)

Contrast: 18.20 [-, 30.56 @] - 40.56

High Choke inspection example

Module 12 Inspections for Seal Camera

This section explains how to set up the inspections. Note that your inspections may be different, depending on your specific part, plant, and process requirements.

The picture below shows an image with all seal inspection regions. We will set these up one at a time.

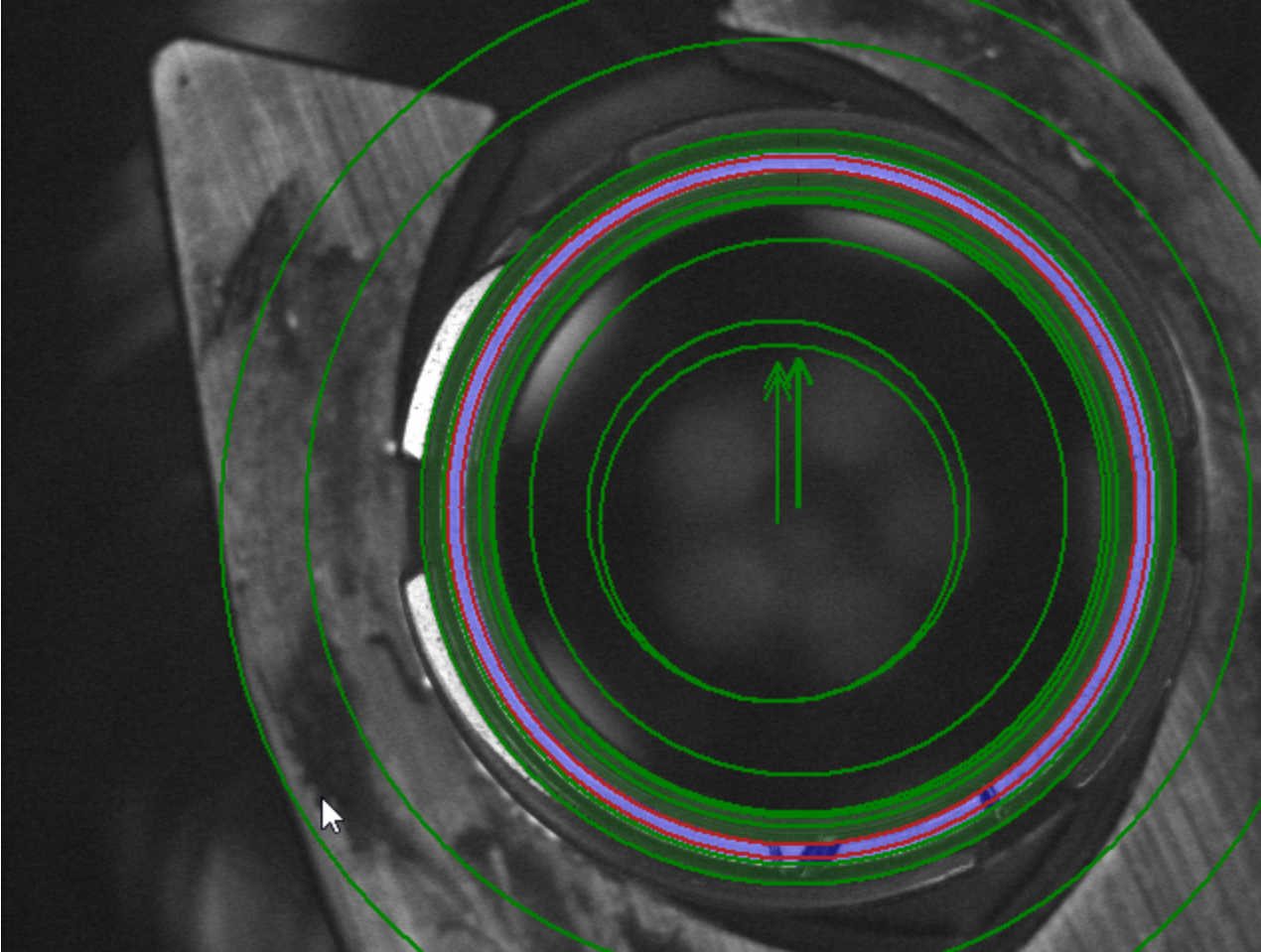

Create the Seal Inspection Tree

The steps below will guide you through the process of building the Seal Inspection Tree, while ensuring that the directory links are connected correctly. First add the inspections, then rename them to something that makes sense to you. Note that we will set up the regions and parameters later. For now, we will just build the inspection tree.

Note for all steps: when you add the inspection, you can rename it immediately.

After each step, select the OK button to save changes, and the Exit button to exit the inspection.

This is how the inspection tree will look

Note: ROI = Region of Interest

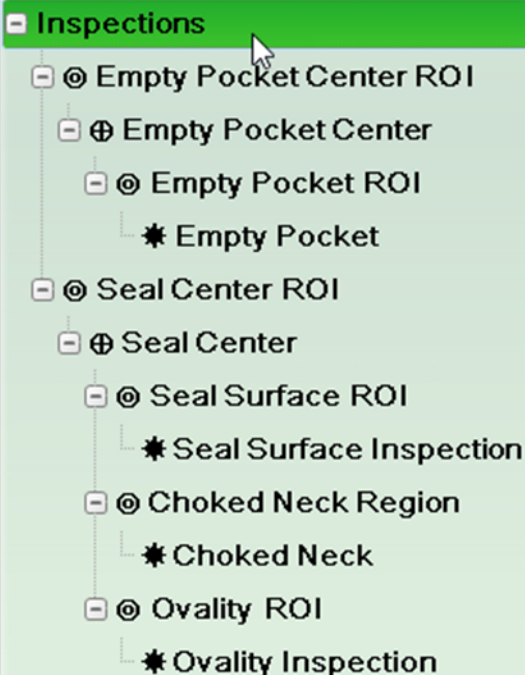

Steps to add the inspections

1. **Inspections** Right-click Inspections. Add | Region | Ring. Rename it Empty Pocket Center ROI.
2. Right-click Empty Pocket Center ROI. Add | Registration | Radial Edge. Rename it Empty Pocket Center.
3. Right-click Empty Pocket Center. Add | Region | Ring. Rename it Empty Pocket ROI.
4. Right-click Empty Pocket ROI. Add | Analysis | Contrast. Rename it Empty Pocket.
5. **Inspections** Right-click Inspections. Add | Region | Ring. Rename it Seal Center ROI.
6. Right-click Seal Center ROI. Add | Registration | Radial Edge. Rename it Seal Center.
7. Right-click Seal Center. Add | Region | Ring. Rename it Seal Surface ROI.
8. Right-click Seal Surface ROI. Add | Analysis | Contrast. Rename it Seal Surface Inspection.
9. Right-click Seal Center. Add | Region | Ring. Rename it Choked Neck Region.
10. Right-click Choked Neck Region. Add | Analysis | Ambient. Rename it Choked Neck.
11. Right-click Seal Center. Add | Region | Ring. Rename it Ovality ROI.
12. Right-click Ovality ROI. Add | Analysis | Measurement. Rename it Ovality Inspection.

Your inspection tree should look similar to that shown on the left.

Place the Empty Pocket Center ROI

An empty pocket inspection must be applied if your system is using a PDX. The Empty Pocket is used to determine if the bottle is in the gripper fingers. If so it allows the inspections to be performed; if not, it stops the inspections from being done.

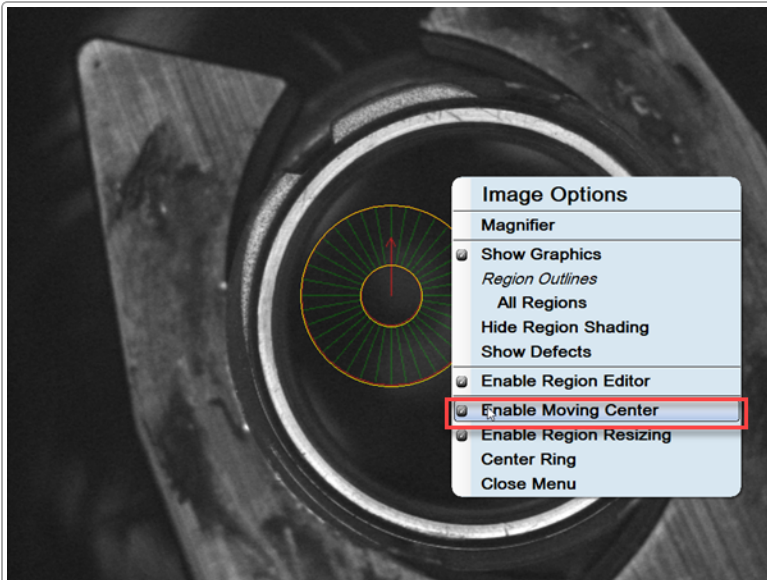

Double-click Empty Pocket Center ROI in the inspection tree.

If you need to see images, put the lane online to acquire several images. Take the lane offline, and select the [+100] button below the image.

We will set up the region of interest so the system knows where to search for the center of the part.

Since the part may be offset from center in the camera's field of view, you may need to move the center of the region.

To move the region:

1. Right-click over the image to see Image Options.
2. Enable Moving Center.
3. Click in the center of the region. A four-way arrow cursor will appear. Click and drag the region to the center of the part (what you see as the center - it does not have to be perfect).

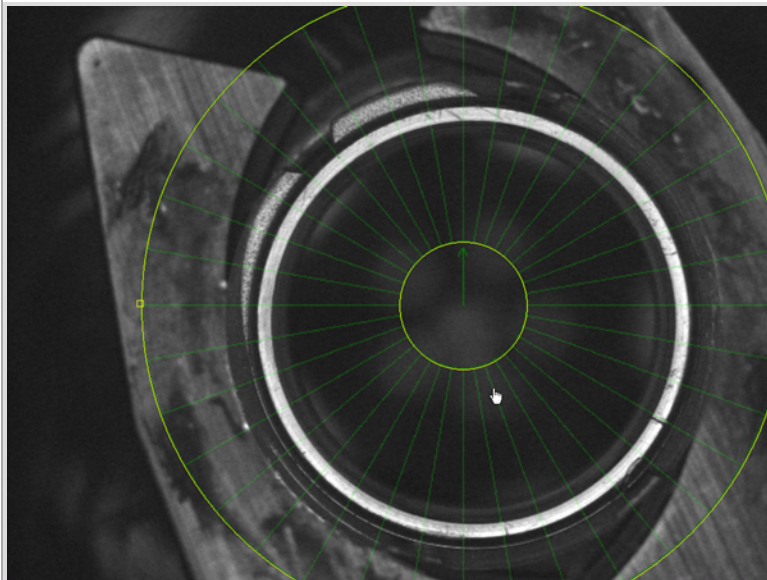

Move the region to surround the seal as shown. Leave enough room for movement from part to part. Scroll through several images to make sure the region surrounds the seal.

Leave the remaining parameters at the default values. Your values may vary, based on your part and system setup.

Empty Pocket Center ROI	
X	60
Y	9
Inner Radius	53
Thickness	215
Use Arc Segments	<input type="checkbox"/> Enabled
Perimeter Type	Normal

Select the OK button to save changes and exit.

Set up the Empty Pocket Center Registration

The Registration searches for edges, to find the center of the part. Since the position changes slightly from part to part, the registration finds the center for each bottle. Once this point is found, the remaining inspections are run to inspect the seal.

The image contains three screenshots of the software interface, each showing a different configuration step for the Empty Pocket Center registration. The first screenshot shows the 'Empty Pocket Center ROI' menu with 'Empty Pocket Center' selected. The 'Search Direction' checkbox is unchecked, and the 'Radial Tolerance' is set to 16. The second screenshot shows the 'Edge Location' menu with 'Edge Polarity' set to 'Dark-to-Light' and 'Use Subpixel' checked. The third screenshot shows the 'Target Circle' menu with the 'Learn' button highlighted by a red arrow.

Edge Location

Empty Pocket Center ROI **Empty Pocket Center** Target Circle

Search Vector Count 36

Search Direction Flipped

Radial Tolerance 16

Diagnosics

Show Edges Enabled

Reject Limits

Qualifying Percent Limits 10.16 .. 50.0

Empty Pocket Center ROI **Empty Pocket Center** Target Circle

Edge Location

Edge Polarity Dark-to-Light

Edge Gradient 0 .. 26

Edge Delta 2

Edge Size 4

Use Subpixel Enabled

Edge Location

Empty Pocket Center ROI **Empty Pocket Center** **Target Circle**

Target Radius 163

Learn **Learn**

Adapting Target Radius Enabled

Double-click Empty Pocket Center in the inspection tree.

By default, the registration will likely fail due to not enough edges found.

To set up the registration:

1. In the Empty Pocket Center menu, uncheck Flipped for Search Direction. This allows the system to search from inside the bottle towards outside the bottle. It will locate the inner edges of the seal.
2. Go to the Edge Location menu.
3. Pay attention to the parameters (outlined in red) shown to the left. Start with these settings, and adjust if needed for your part.
4. Go to the Target Circle tab. Click the Learn button. This allows the system to learn where the edges will fall.
5. Leave the remaining parameters at the default values. Your values may vary, based on your part and system setup.

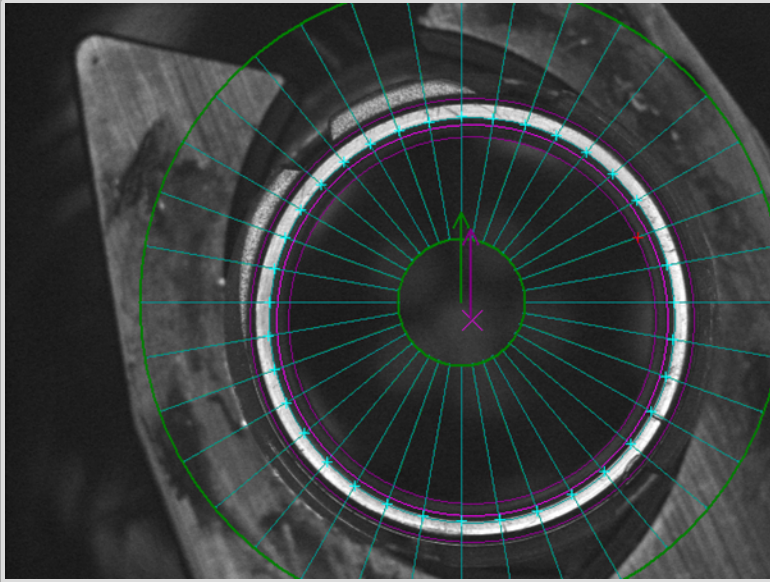

The system should now find the edges of the seal.

Scroll through several images to make sure the seal is located consistently. Make adjustments if needed.



Select the OK button to save changes and exit.

Place the Empty Pocket ROI

We will set up the location for the system to check for empty pockets.

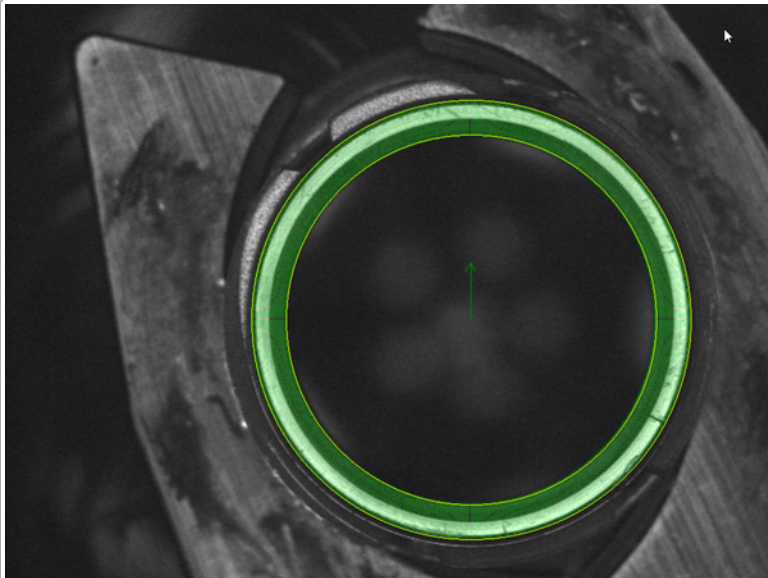

Double-click Empty Pocket ROI in the inspection tree to edit it.

To place the region:

1. Click on the outer edge to move it outside of the seal, and then the inner edge to move it inside of the seal edge, as shown.
2. Leave the remaining parameters at the default values. Your values may vary, based on your part and system setup.
3.  Select the OK button to save changes and exit.

Empty Pocket ROI	
X	0
Y	0
Inner Radius	154
Thickness	29
Use Arc Segments	<input type="checkbox"/> Enabled
Perimeter Type	Normal

Set Up the Seal Empty Pocket Inspection

The Empty Pocket inspection allows us to determine whether a part is present in the camera's field of view. If there is no part, then subsequent inspections will not run. This saves processing time, as well as keeping statistics correct.

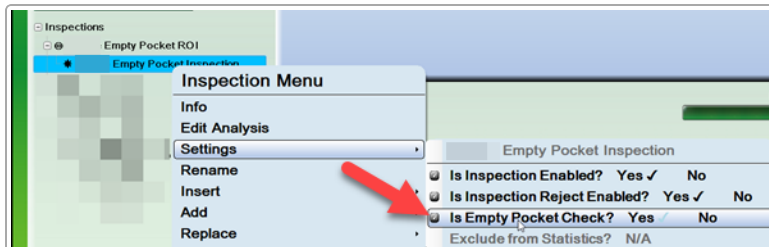

In the Inspection Tree, right-click over Empty Pocket. Select Settings | Is Empty Pocket Check? Click to enable it.

The system will give a warning that rejecting is off. This is OK.

The name of the Empty Pocket inspection will have a blue background in the inspection tree.

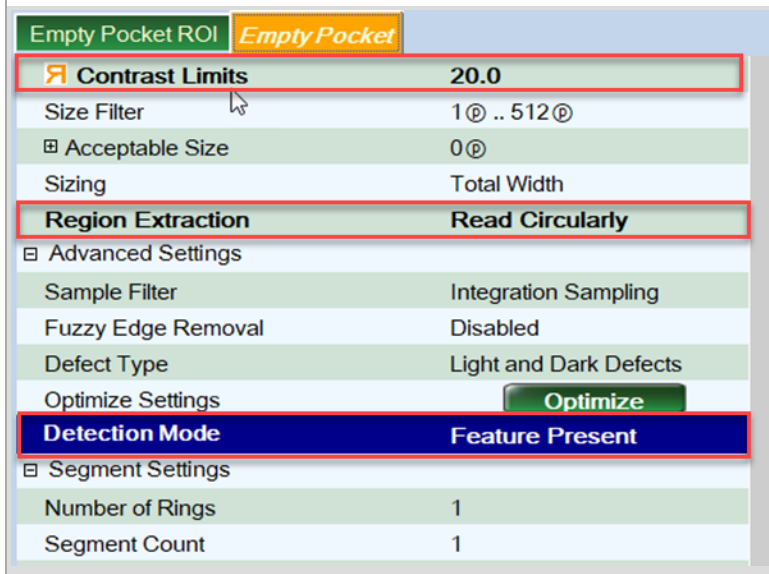

Double-click Empty Pocket in the inspection tree.

Pay attention to the parameters (outlined in red) shown to the left. Start with these settings, and adjust if needed for your part.

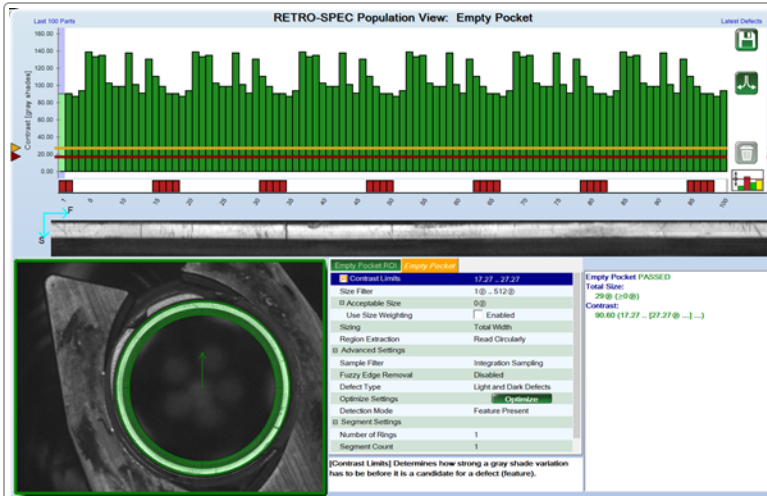

Images with parts in the field of view should pass the inspection. If a part was missing, it would fail.



Select the OK button to save changes and exit.

Place the Seal Center ROI

We will set up the location for the system to inspect the seal.



Double-click Seal Center ROI name in the inspection tree.

Since the part may be offset from center in the camera's field of view, you may need to move the center of the region.

To move the region:

1. Right-click over the image to see Image Options.
2. Enable Moving Center.
3. Click in the center of the region. A four-way arrow cursor will appear. Click and drag the region to the center of the part (what you see as the center - it does not have to be perfect).

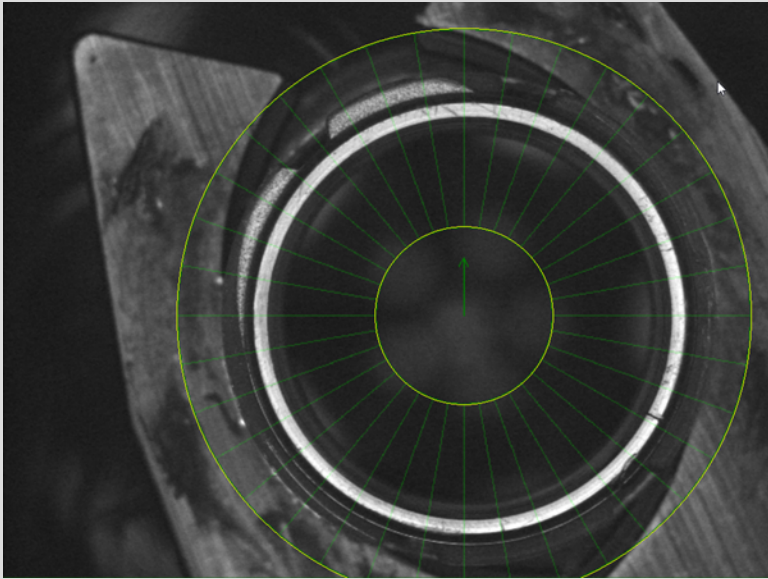

To place the region:

1. Click on the outer edge to move it outside of the seal surface, and then the inner edge to move it inside the seal surface, as shown below.
2. Scroll through several images to make sure the seal is surrounded regardless of part position.
3. Leave the remaining parameters at the default values. Your values may vary, based on your part and system setup.
4. Select the OK button to save changes and exit.

Seal Center ROI	
X	64
Y	21
Inner Radius	74
Thickness	165
Use Arc Segments	<input type="checkbox"/> Enabled
Perimeter Type	Normal

Set up the Seal Center Registration

The Registration searches for edges, to find the center of the part. Since the position changes slightly from part to part, the registration finds the center for each bottle. Once this point is found, the remaining inspections are run to inspect the seal.

The image shows three screenshots of the software interface, illustrating the steps to set up Seal Center Registration. The first screenshot shows the 'Seal Center ROI' tab with 'Seal Center' selected. The 'Search Direction' checkbox is checked, and it is highlighted with a red box. The second screenshot shows the 'Edge Location' tab with 'Edge Location' selected. The 'Edge Polarity' is set to 'Dark-to-Light', 'Edge Gradient' is '0 .. 45', 'Edge Delta' is '2', 'Edge Size' is '4', and 'Use Subpixel' is checked. This entire section is highlighted with a red box. The third screenshot shows the 'Target Circle' tab with 'Target Circle' selected. The 'Target Radius' is '168', and the 'Learn' button is highlighted with a red arrow.

Seal Center ROI	Seal Center	Target Circle	Edge Location
Search Vector Count	36		
Search Direction	<input checked="" type="checkbox"/> Flipped		
Radial Tolerance	5		
Diagnostics	<input type="checkbox"/>		
Show Edges	<input checked="" type="checkbox"/> Enabled		
Reject Limits	<input type="checkbox"/>		
Qualifying Percent Limits	25.0 .. 50.0		

Seal Center ROI	Seal Center	Target Circle	Edge Location
Edge Polarity	Dark-to-Light		
Edge Gradient	0 .. 45		
Edge Delta	2		
Edge Size	4		
Use Subpixel	<input checked="" type="checkbox"/> Enabled		

Seal Center ROI	Seal Center	Target Circle	Edge Location
Target Radius	168		
Learn	<input type="checkbox"/>	<input checked="" type="checkbox"/> Learn	
Adapting Target Radius	<input type="checkbox"/> Enabled		

Double-click Seal Center in the inspection tree.

By default, the registration will likely fail due to not enough edges found.

To set up the registration:

1. In the Seal Center menu, uncheck Flipped for Search Direction. This allows the system to search from inside the bottle towards outside the bottle. It will locate the inner edges of the seal.
2. Go to the Edge Location menu.
3. Pay attention to the parameters (outlined in red) shown to the left. Start with these settings, and adjust if needed for your part.
4. Go to the Target Circle tab. Click the Learn button. This allows the system to learn where the edges will fall.
5. Leave the remaining parameters at the default values. Your values may vary, based on your part and system setup.

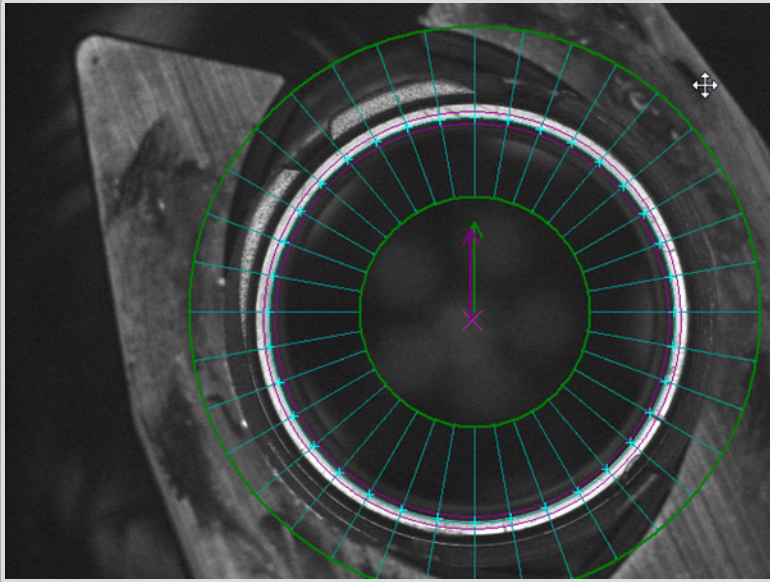

The system should now find the edges of the seal.

Scroll through several images to make sure the inner edge of the seal is found consistently. Make adjustments if needed.



Select the OK button to save changes and exit.

Place the Seal Surface ROI

We will place the region to detect defects on the seal surface.

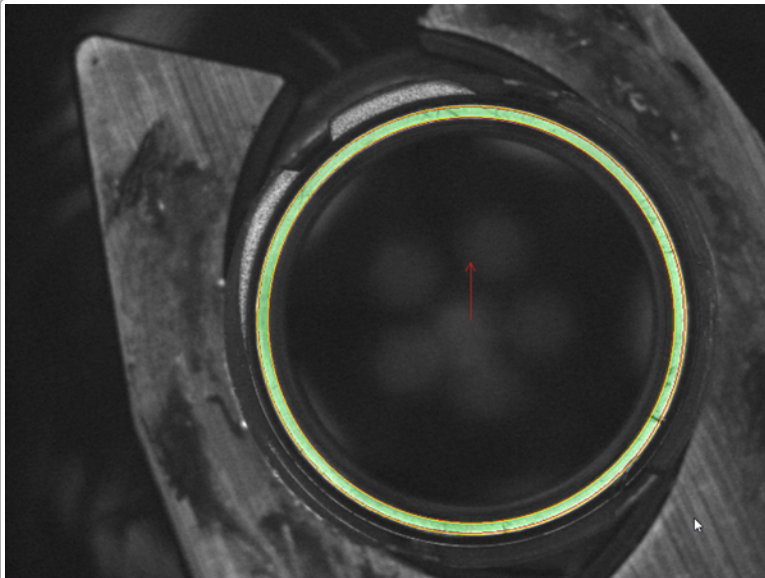

Seal Surface ROI	
X	0
Y	0
Inner Radius	169
Thickness	9
Use Arc Segments	<input type="checkbox"/> Enabled
Perimeter Type	Normal

Double-click Seal Surface ROI in the inspection tree.

To place the region:

1. Click on the outer edge to move it, and then the inner edge to move it.
2. Position this region directly over the seal.
3. Leave the remaining parameters at the default values. Your values may vary, based on your part and system setup.
4. Select the OK button to save changes and exit.

Set up the Seal Surface Inspection

We are using a Contrast inspection to find defects on the seal surface.

The screenshot shows the 'Seal Surface ROI' settings for 'Seal Surface Inspection'. The 'Contrast Limits' section is highlighted with a red border and shows a value of 49.52. Below it, various parameters are listed, including 'Size Filter', 'Acceptable Size', 'Sizing', 'Region Extraction', 'Advanced Settings', 'Sample Filter', 'Fuzzy Edge Removal', 'Defect Type', 'Optimize Settings', 'Detection Mode', 'Segment Settings', 'Number of Rings', and 'Segment Count'. An 'Optimize' button is visible next to the 'Optimize Settings' parameter.

Below the settings panel is a 'RETRO-SPEC Population View: Seal Surface Inspection' graph. The graph shows a distribution of 'Last 100 Parts' with a y-axis labeled 'Count [gray shaded]' ranging from 0 to 140.00. The x-axis represents individual parts. A red horizontal bar is positioned at approximately 60 on the y-axis, and a red vertical bar is positioned at the 50th part. A hand cursor is pointing at the red horizontal bar.

Double-click Seal Surface in the inspection tree.

To set up the inspection:

1. Pay attention to the parameters (outlined in red) shown to the left. Start with these settings, and adjust if needed for your part.
2. Make sure parts are passing or failing as expected. An example is shown below.
3. You can move the red horizontal bar in the graph closer to zero to make the inspection more sensitive, or further from the center to make the inspection less sensitive.
4.  Select the OK button to save changes and exit.

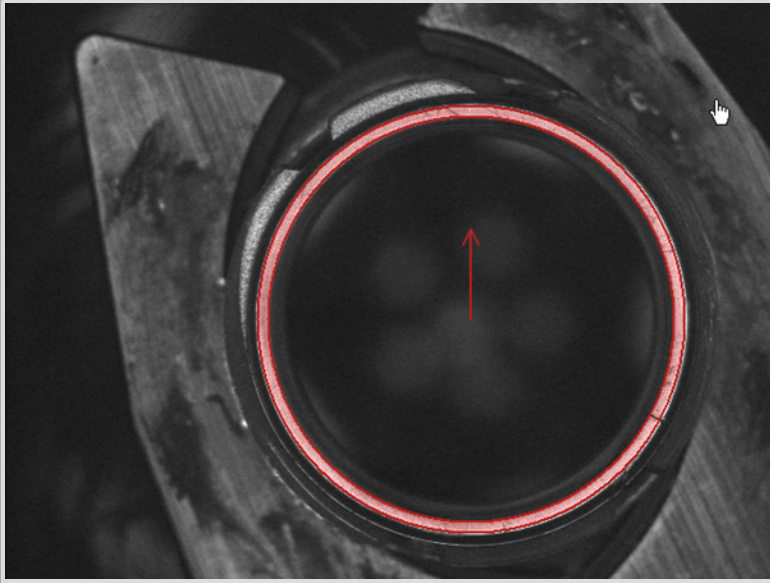

Example seal surface defect

Place the Choked Neck ROI

We will place the region in the area where choked necks typically appear in the image.

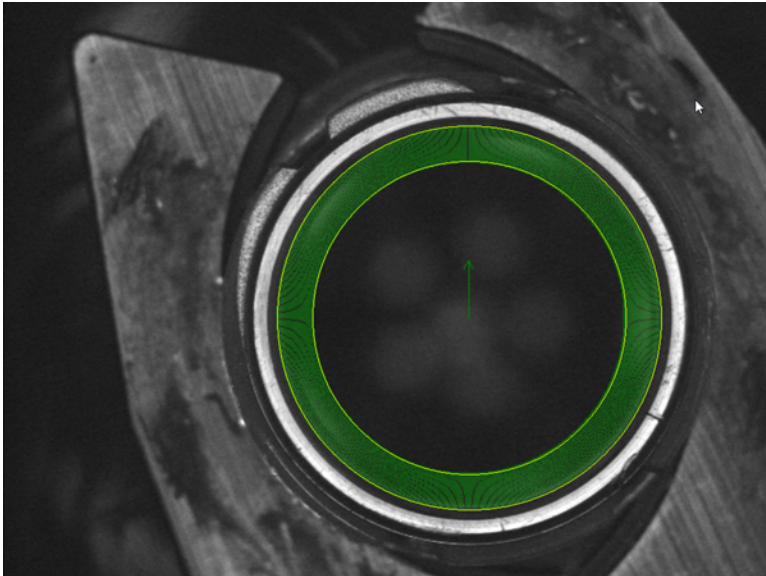

Double-click Choked Neck Region in the inspection tree.

To place the region:

1. Click on the outer edge to move it, and then the inner edge to move it.
2. Position this region inside of the seal, where choked necks typically occur.
3. Leave the remaining parameters at the default values. Your values may vary, based on your part and system setup.
4.  Select the OK button to save changes and exit.

<i>Choked Neck Region</i> 	
X	0
Y	0
Inner Radius	130
Thickness	30
Use Arc Segments	<input type="checkbox"/> Enabled
Perimeter Type	Normal

Set up the Choked Neck Inspection

We are using an Ambient inspection to detect choked necks.

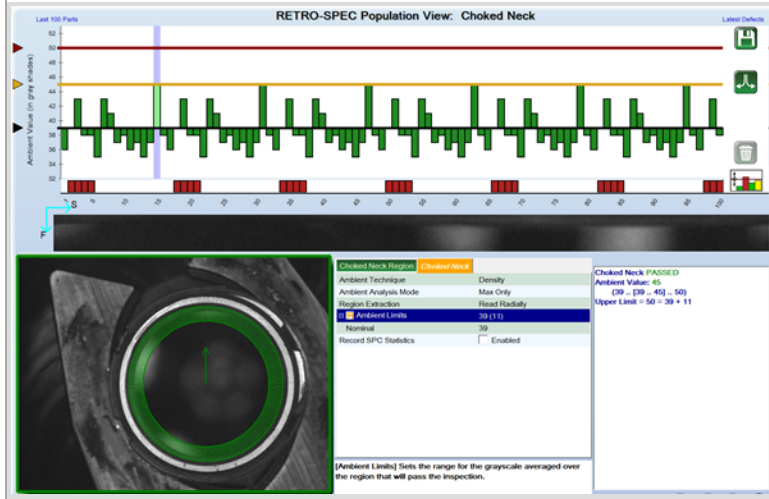
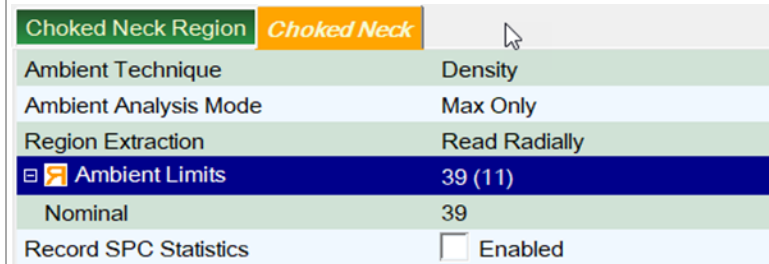
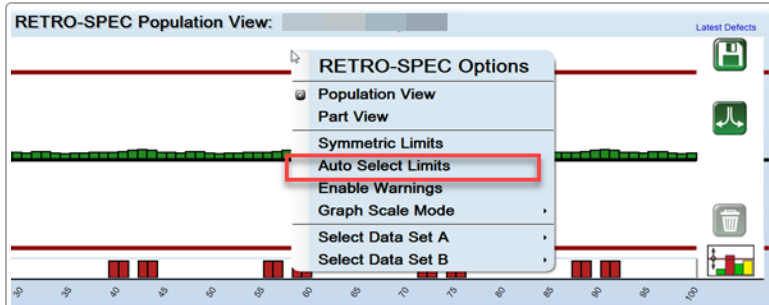

Double-click Choked Neck in the inspection tree.

To set up the inspection:

1.  Put the lane online to acquire several images, and select the [+100] button.
2. Take the lane offline.
3. Right-click over the Retro-Spec Population View graph and choose Auto-Select Limits. The system will automatically set the inspection limits based on your parts.
4. Leave the remaining parameters at the default values. Your values may vary, based on your part and system setup.

To test the inspection:

1. Scroll through the images to make sure parts are passing (or failing) as expected.
2. You can make the inspection more sensitive by moving the red horizontal bars on the Retro-Spec graph closer to center, or less sensitive by moving the red horizontal bars away from center.

Choked Neck inspection example

-  Select the OK button to save changes and exit.

Place the Ovality ROI

We will place the region to surround the seal surface.

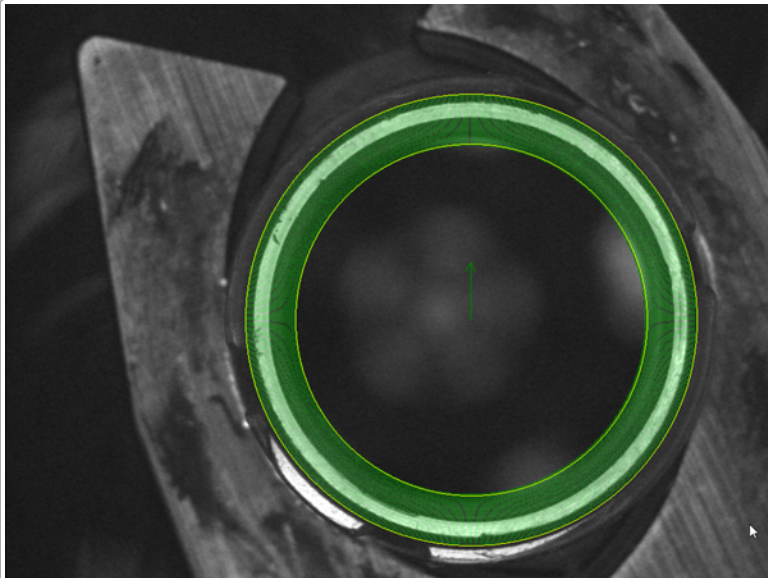

Double-click Ovality ROI in the inspection tree.

To place the region:

1. Click on the outer edge to move it, and then the inner edge to move it.
2. Position this region over the seal as shown.
3. Leave the remaining parameters at the default values. Your values may vary, based on your part and system setup.
4. Select the OK button to save changes and exit.

Ovality ROI	
X	0
Y	0
Inner Radius	146
Thickness	42
Use Arc Segments	<input type="checkbox"/> Enabled
Perimeter Type	Normal

Set up the Ovality Inspection

We are using a Measurement inspection to detect ovality on the seal. It determines the inner and outer width, and compares it to a standard that you set.

Calibration

Ovality ROI **Ovality Inspection** Inner Outer Width Contrast

Learn Settings **Learn**

Fuzzy Edge Removal	Disabled
Feature Type	Borders: Both Dark
Feature Selection Logic	Highest Contrast
Border Sharpness	1 .. 9
Balance	1.0
Balance Side	Disabled
Sample Count	36
Allowed Gap Size	0 .. 0

Calibration

Ovality ROI Ovality Inspection **Inner** Outer Width Contrast

<input checked="" type="checkbox"/> Inner Diameter	337.39@
<input type="checkbox"/> <input checked="" type="checkbox"/> Min/Max	337.39@ +5.07@/-5.75@
Record SPC Statistics	Disabled
<input type="checkbox"/> <input checked="" type="checkbox"/> Average	337.39@ +/-4.8@
Record SPC Statistics	<input type="checkbox"/> Enabled
<input type="checkbox"/> <input checked="" type="checkbox"/> Range	4.44@
Record SPC Statistics	<input type="checkbox"/> Enabled
<input type="checkbox"/> Continuity	+42.0@/-42.0@
Units	pixel
Calibration Factor	1.0
Measured Distance	-1.0@

Double-click Ovality Inspection in the inspection tree.

To set up the inspection:

1.  Put the lane online to acquire several images, and select the [+100] button.
2. Take the lane offline.
3. In the Ovality Inspection menu, select a Feature Type. We are using Borders: Both Dark in our example because the outside of the seal has dark pixels on both sides.
4. Go to the Inner menu and enable Inner Diameter.
5. Uncheck Continuity.
6. Go to the Outer menu and enable Outer Diameter.
7. Uncheck Continuity.
8. Go to the Width menu and enable Width.
9. Uncheck Range and Continuity.
10. Go to the Ovality Inspection menu.
11. Select the Learn button. The system will automatically set the values in the menus based on your part population.
12. Leave the remaining parameters at the default values. Your values may vary, based on your part and system setup.

Calibration					
Ovality ROI	Ovality Inspection	Inner	Outer	Width	Contrast
<input checked="" type="checkbox"/>	Outer Diameter		360.48 @		
<input type="checkbox"/>	<input checked="" type="checkbox"/> Min/Max		360.48 @ +3.84 @/ -4.45 @		
	Record SPC Statistics		Disabled		
<input type="checkbox"/>	<input checked="" type="checkbox"/> Average		360.48 @ +2.89 @/ -3.85 @		
	Record SPC Statistics		<input type="checkbox"/> Enabled		
<input type="checkbox"/>	<input checked="" type="checkbox"/> Range		4.74 @		
	Record SPC Statistics		<input type="checkbox"/> Enabled		
<input type="checkbox"/>	Continuity		+3.0 @/ -2.7 @		
	Units		pixel		
	Calibration Factor		1.0		
	Measured Distance		-1.0 @		

Calibration					
Ovality ROI	Ovality Inspection	Inner	Outer	Width	Contrast
<input checked="" type="checkbox"/>	Width		11.55 @		
<input type="checkbox"/>	Min/Max		11.55 @ +0.0 @/ -11.55 @		
<input type="checkbox"/>	<input checked="" type="checkbox"/> Average		11.55 @ +/-3.54 @		
	Record SPC Statistics		<input type="checkbox"/> Enabled		
<input type="checkbox"/>	Range		42.0 @		
<input type="checkbox"/>	Continuity		+42.0 @/ -42.0 @		
	Units		pixel		
	Calibration Factor		1.0		
	Measured Distance		-1.0 @		

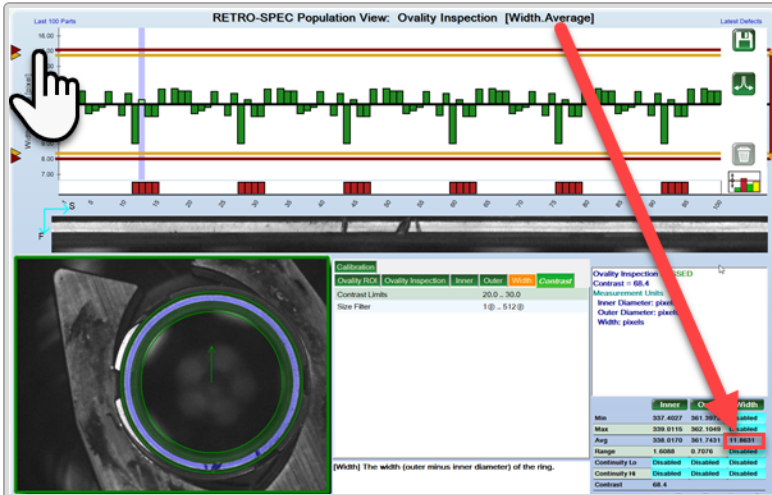

To test the inspection:

1. Scroll through several images to make sure the inspection is passing (or failing) as expected.
2. You can move the red horizontal bars towards the black line in the upper graph to make the inspection more sensitive (fail more bottles), or away from the black line to make it less sensitive (pass more bottles).

Select any of the measurements in the lower right corner. The graph changes depending which measurement you are looking at. You can adjust the sensitivity for any of the measurements separately.



Select the OK button to save changes and exit.

OPTIONAL: you can verify measurements. You will need to measure a good seal to get the measurements to which the system will compare.

To get measurements:

1. Right-click over the Seal button. Select Image | Image Analysis.

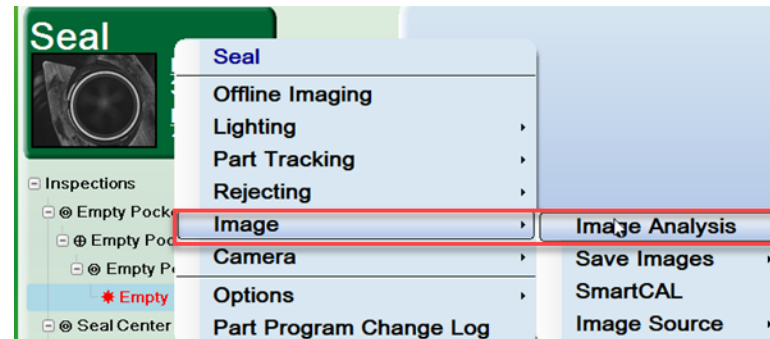

2. Click the Snap button to see a good seal image. You may need to click the button several times until you see a typical good seal.



3. Select the line button in Image Analysis.
4. Move the line and stretch it so the line crosses the seal at the widest point.
5. Move the yellow box and circle (markers) so they fall on the outside of the seal. You can use the upper graph to position these points more precisely (where the change in grey level drops off).
6. Write down the Distance value between these points. This will be the value we use for Outer Diameter.
7. Move the markers to the inner edges of the seal.
8. Write down the Distance value between these points. This will be the value we use for Inner Diameter.
9. Move the markers to the edges of one side of the seal.
10. Write down the Distance between these points. This will be the value we use for Width.
11. Select the OK button to save changes and exit.

With your written measurements, go back to the Ovality Inspection and run the

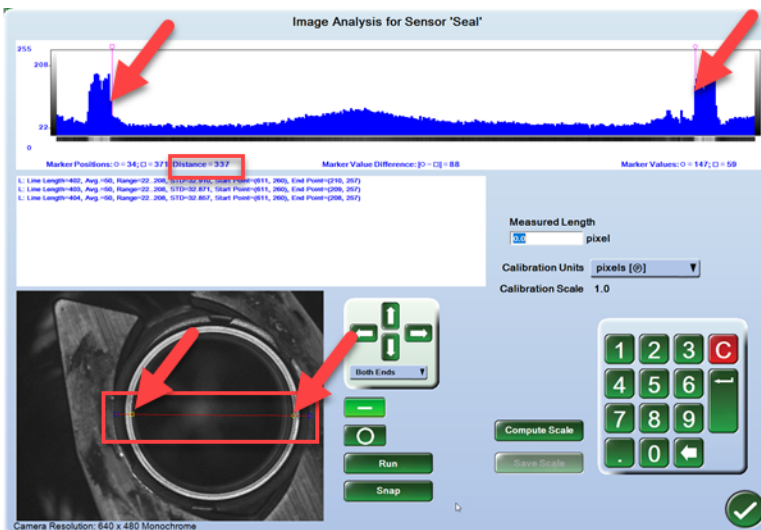
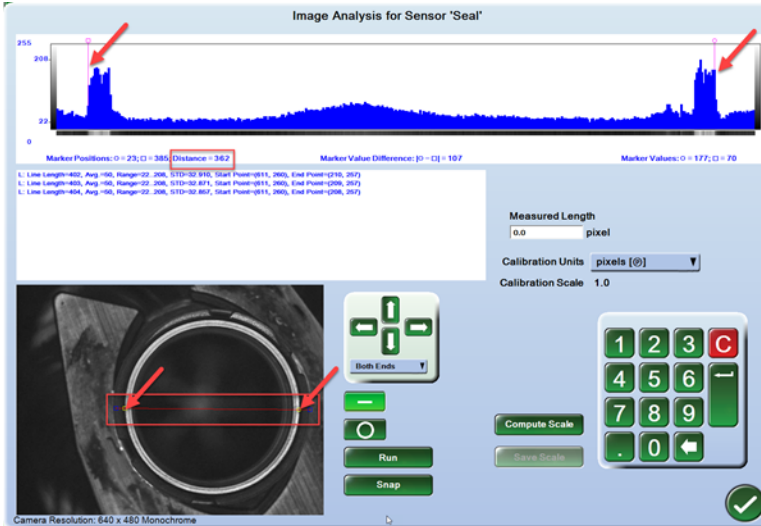

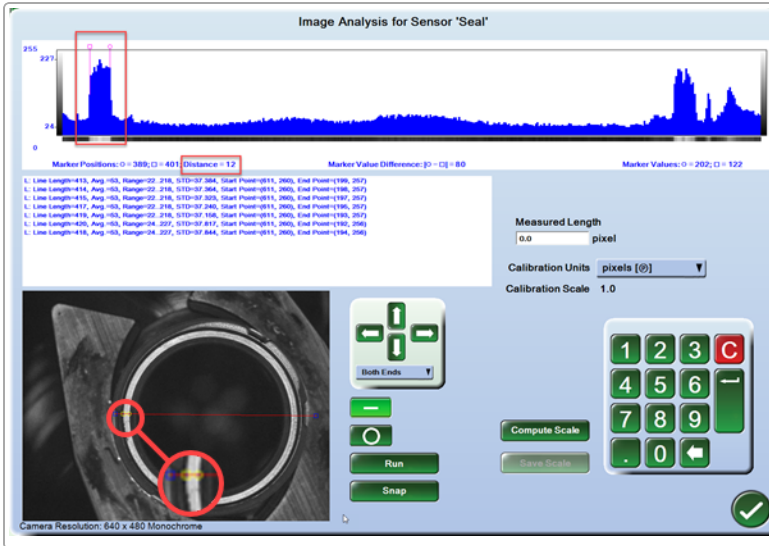

inspection. Compare your written values to the values measured by the inspection.

Module 12 Inspections for Intellimass

This section explains how to set up the inspections. Note that your inspections may be different, depending on your specific part, plant, and process requirements.

Note: The Intellimass modules are optional additional modules that must be purchased separately.

This section explains how to set up the Intellimass inspections. The modules do not have cameras; they are infrared sensors that measure the overall thickness of the base or sidewall of a part. Therefore, the images on screen are measurements instead of pictures of the part.

Create the Base Mass Inspection Tree

The steps below will guide you through the process of building the Base Mass Inspection Tree, while ensuring that the directory links are connected correctly. First add the inspections, then rename them to something that makes sense to you. Note that we will set up the regions and parameters later. For now, we will just build the inspection tree.

Note for all steps: when you add the inspection, you can rename it immediately.

After each step, select the OK button to save changes, and the Exit button to exit the inspection.

This is how the inspection tree will look



Steps to add the inspections

1. **Inspections** Right-click Inspections. Add | Mass Empty Pocket. Rename it Base Mass Empty Pocket.
2. Right-click Base Mass Empty Pocket. Add | Mass Inspection. Rename it Base Mass.

Note: only one Empty Pocket and one Mass inspection are permitted for each mass sensor part program. If you have already added either of these to the part program, then they are not available to add from the Inspection menu (even if one is disabled).

Your inspection tree should look similar to that shown on the left.

Set Up the Base Mass Empty Pocket Inspection

The Empty Pocket inspection determines whether a part is present. If no part is present, then subsequent inspections will not take place. This keeps statistics correct, and saves inspection time.

Note that the system already considers this an empty pocket inspection (that is, you do not have to enable Empty Pocket in the settings).

The name of the Empty Pocket inspection will have a blue background in the inspection tree.

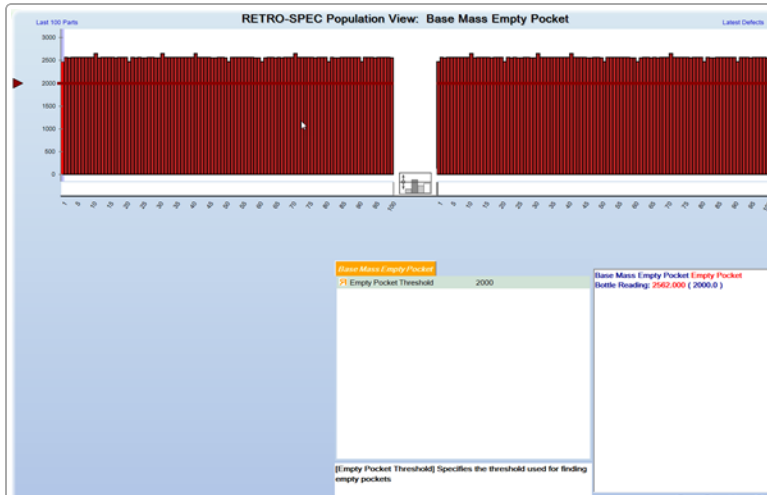

Put the lane online and allow the system to acquire several images, then take the lane offline. You may see a warning about "Side Mass" having no inspections. This is OK. We will set that up later.

Double-click Base Mass Empty Pocket in the inspection tree. The inspection will likely show failed parts initially. The red bars indicate the base mass measurements.

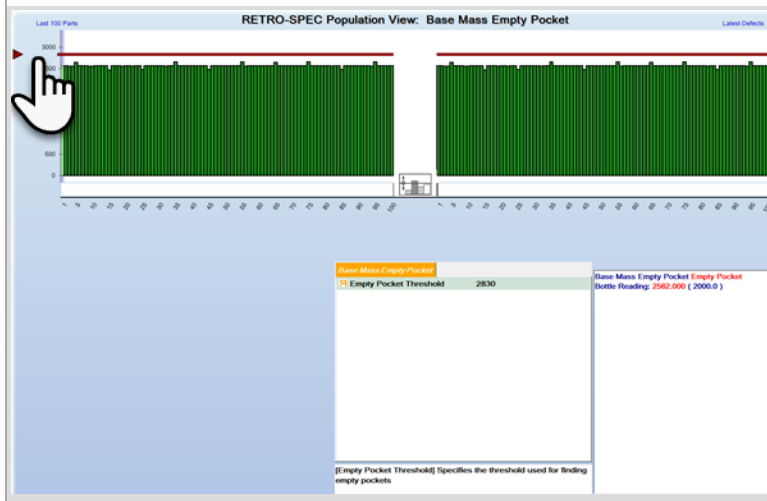

Move the red horizontal line above the vertical bars so that the bars turn green. This allows the inspection to pass.

Select the OK button to save changes and exit.

Set up the Base Mass Inspection

We are using a Mass inspection to set the limits that determine whether parts pass or fail.

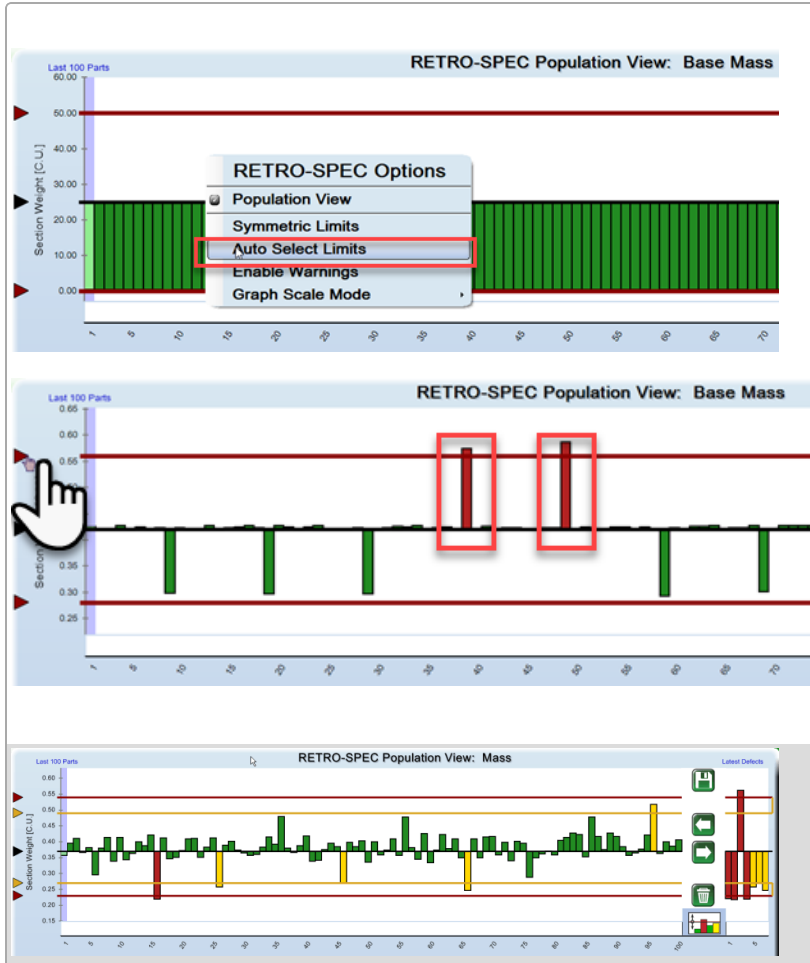

To set up the inspection:

1. Before editing the inspection, put the lane online to acquire several readings.
2. Double-click Base Mass in the inspection tree.
3. Take the lane offline.
4. Right-click over the Retro-Spec Population View graph and choose Auto-Select Limits. The system will automatically set the inspection limits based on your parts.
5. You can move the red horizontal bars in the graph closer to center to make the inspection more sensitive, or further from center to make the inspection less sensitive.
6. In our example, the parts with red bars will fail. This means those parts are outside of the Mass limits we set.

Base Mass

Mass Limits

0.42 +0.14/ -0.14

7.  Select the OK button to save changes and exit.

Example Base Mass inspection

Create the Sidewall Mass Inspection Tree

The steps below will guide you through the process of building the Sidewall Mass Inspection Tree, while ensuring that the directory links are connected correctly. First add the inspections, then rename them to something that makes sense to you. Note that we will set up the regions and parameters later. For now, we will just build the inspection tree.

Note: the setup procedure for Sidewall mass is the same as Base mass

Note for all steps: when you add the inspection, you can rename it immediately.

After each step, select the OK button to save changes, and the Exit button to exit the inspection.

This is how the inspection tree will look

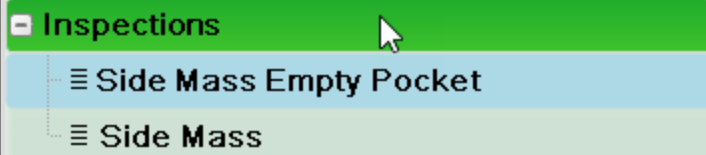

Steps to add the inspections

1. **Inspections** Right-click Inspections. Add | Mass Empty Pocket. Rename it Side Mass Empty Pocket.
2. Right-click Side Mass Empty Pocket. Add | Mass Inspection. Rename it Side Mass.

Note: only one Empty Pocket and one Mass inspection are permitted for each mass sensor part program. If you have already added either of these to the part program, then they are not available to add from the Inspection menu (even if one is disabled).

Your inspection tree should look similar to that shown on the left.

Set Up the Side Mass Empty Pocket Inspection

The Empty Pocket inspection determines whether a part is present. If no part is present, then subsequent inspections will not take place. This keeps statistics correct, and saves inspection time.

Note that the system already considers this an empty pocket inspection (that is, you do not have to enable Empty Pocket in the settings).

The name of the Empty Pocket inspection will have a blue background in the inspection tree.

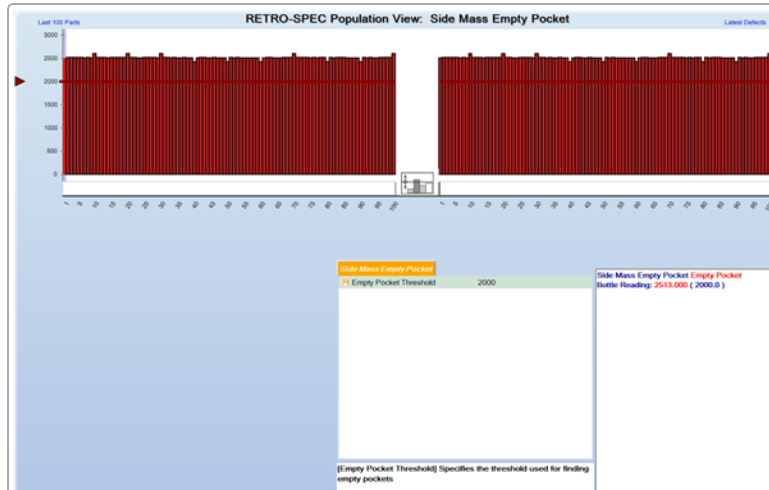

Put the lane online and allow the system to acquire several images. Take the lane offline.

Double-click the Empty Pocket inspection in the inspection tree. The inspection will likely show failed parts initially. The red bars indicate the side mass measurements.

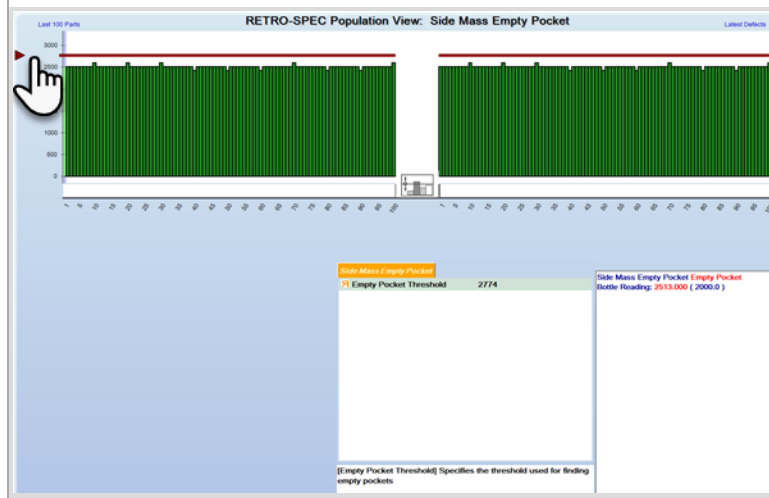

Move the red horizontal line above the vertical bars so that the bars turn green. This allows the inspection to pass.



Select the OK button to save changes and exit.

Set up the Side Mass Inspection

We are using a Mass inspection to set the limits that determine whether parts pass or fail.

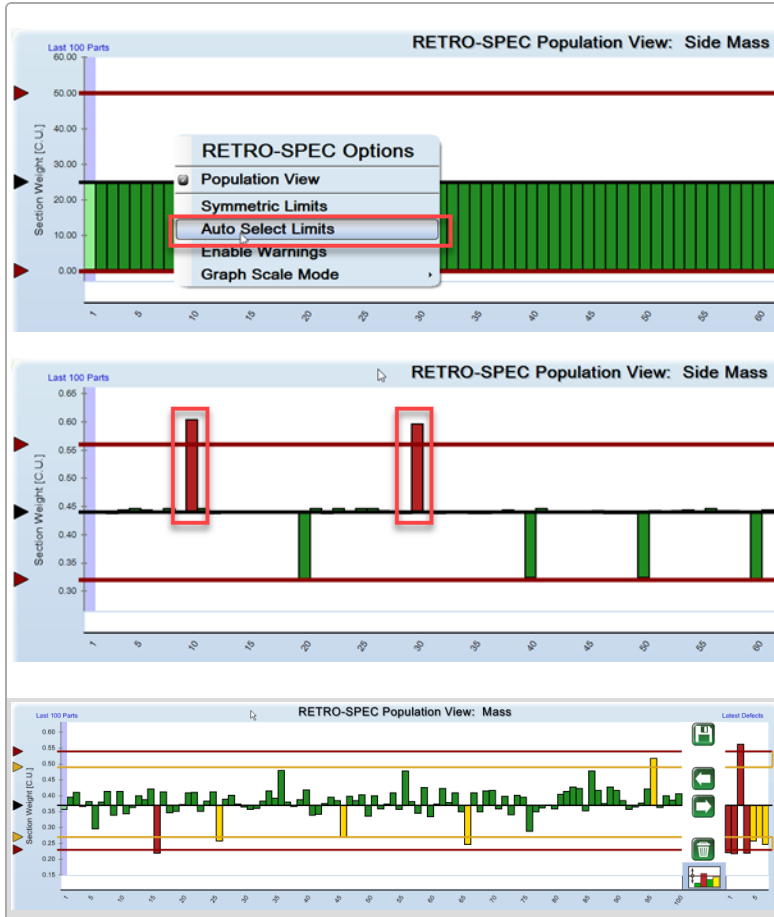

To set up the inspection:

1. Before editing the inspection, put the lane online to acquire several readings. Take the lane offline.
2. Double-click the Side Mass inspection name in the inspection tree.
3. Right-click over the Retro-Spec Population View graph and choose Auto-Select Limits. The system will automatically set the inspection limits based on your parts.
4. You can move the red horizontal bars in the graph closer to center to make the inspection more sensitive, or further from center to make the inspection less sensitive.
5. In our example, the parts with red bars will fail. This means those parts are outside of the Mass limits we set.

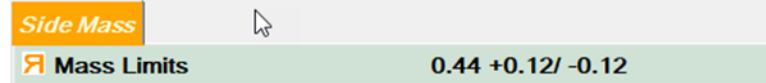

6.  Select the OK button to save changes and exit.

Example Mass inspection